

# MUTOH

## OPERATION MANUAL

Full-Color Inkjet Printer

*ValueJet*

VJ-1626UH

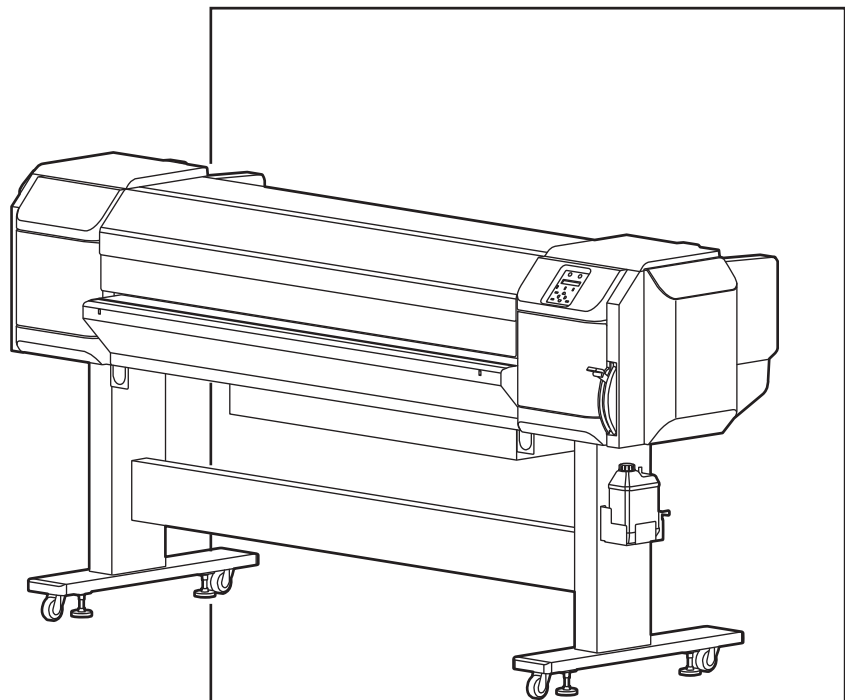

Read This Manual Before Using The  
Printer.

Rev.

VJ1626UHE-A-03



## Important Notice

### 1. For Users in Europe



The CE marking is a mandatory European marking for certain product groups to indicate conformity with the essential health and safety requirements set out in European Directives.

By affixing the CE marking, the manufacturer, his authorized representative, or the person placing the product on the market or putting it into service ensures that the item meets all the essential requirements of all applicable EU directives and that the applicable conformity assessment procedures have been applied.

### 2. For Users in the United States

This equipment has been tested and found to comply with the limits for a Class A digital device, pursuant to Part 15 of the FCC Rules.

These limits are designed to provide reasonable protection against harmful interference when the equipment is operated in a commercial environment.

This equipment generates, uses, and can radiate radio frequency energy and, if not installed and used in accordance with the instruction manual, may cause harmful interference to radio communications.

Operation of this equipment in a residential area is likely to cause harmful interference in which case the user will be required to correct the interference at his own expense.

### 3. Trademark Mentioned in this Manual

- MUTOH, ValueJet, VJ-1626UH, MH-RTL are registered trademarks or product names of MUTOH INDUSTRIES LTD.
- Windows 10, Windows 8 and Windows 7 are registered trademarks or product names of Microsoft Corporation.
- Other company and product names may be registered trademarks or product names.

**NOTE**

- No part of this product or publication may be reproduced, copied, or transmitted in any form or by any means, except for personal use, without the permission of MUTOH INDUSTRIES LTD.
  - The product and the contents of this publication may be changed without prior notification.
  - MUTOH INDUSTRIES LTD. has made the best efforts to keep this publication free from error, but if you find any uncertainties or misprints, please call us or the shop where you bought this equipment.
  - MUTOH INDUSTRIES LTD. shall not be liable for any damages or troubles resulting from the use of this equipment or this manual.
-



# About this Manual

## 1. Contents of the Manual

There are three manuals for this product.

### **Installation manual**

Explains operating procedures along with unpacking, installation and preparation before use.

### **Product Activation Guide**

This manual explains the operation procedure when you start the printer for the first time.

### **Operation Manual (this manual)**

## 2. Purpose and Target Readers

This manual explains preparations before use and operation procedures for MUTOH Full Color Ink Jet Printer VJ-1626UH.

This manual is prepared for the owners and operators of this printer.

Before using this printer, fully understand the contents and directions in this manual.

### 3. Manual Configuration





Section	Description
1 Safety instructions	This chapter explains warning terms, safety precautions and warning labels on the product that operators and people who install this product need to know.
2 Product overview	This chapter explains the features of the printer along with the names and functions of each part.
3 Before using	This chapter explains necessary steps before using the printer.
4 Handling the printer	This chapter explains how to handle the printer.
5 Panel setup menu	The section explains the Setup menu of the printer.
6 Maintenance	This chapter describes daily maintenance of the product.
7 Troubleshooting	This chapter describes possible troubles during the use of this product and countermeasures.
8 Appendix	This chapter describes specifications and included components with this printer.

#### NOTE

- “1 Safety instructions” to “4 Handling the printer” must be read before using the printer.
- Read “5 Panel setup menu” through “8 Appendix” as necessary.

### 4. Manual Notation

This section explains general cautions that must be followed in order to use this printer safely.

Warning	Meaning
 <b>WARNING</b>	Used for dangerous situations where death or serious injury may be caused.
 <b>CAUTION</b>	Used for dangerous situations that may cause slight or medium injury, or when all or parts of products are damaged.
<b>NOTE</b>	It is used for special cautions and for information that needs to be emphasized.
<b>TIP</b>	Indicates useful tips for operating or understanding the printer.
	Indicates “prohibited” operations.
	Indicates “required” operations.
	Indicates reference pages in this manual.

# TABLE OF CONTENTS

---

## 1 Safety instructions

1.1	Types and meanings of warnings .....	12
1.2	Important safety instructions .....	13
1.3	Warning labels .....	16
1.3.1	Handling the warning labels. ....	16
1.3.2	Location and type of warning labels .....	17

## 2 Product overview

2.1	Features .....	24
2.2	Names of parts and functions. ....	25
2.2.1	Front section .....	25
2.2.2	Rear section. ....	27
2.2.3	Operation panel .....	28
2.2.4	Indicator display. ....	31
2.3	Printer status .....	34
2.3.1	Number of colors to be used .....	34
2.3.2	Normal .....	34
2.3.3	Setup menu display .....	34
2.3.4	Changing printer status .....	35

## 3 Before using

3.1	Power cable connection .....	38
3.2	Turning the power ON/OFF .....	42
3.2.1	Turning the power ON .....	42
3.2.2	Turning the power OFF .....	43
3.3	Sleep mode .....	45
3.3.1	Set sleep mode on the printer .....	46
3.3.2	Recover the printer from sleep mode .....	51
3.4	Initial ink charging .....	52
3.5	Setting media .....	61
3.5.1	Installing Media-feed table. ....	61
3.5.2	Loading rigid media .....	72
3.5.3	Removing Media-feed table (optional). ....	81
3.5.4	Loading roll media .....	84
3.5.5	Setting roll media .....	87
3.5.6	Setting media type .....	93

3.5.7	Media Type Change Procedure from Media Type Menu . . . . .	96
<b>3.6</b>	<b>Test print. . . . .</b>	<b>105</b>
3.6.1	Nozzle check . . . . .	108
3.6.2	Nozzle check B . . . . .	109
3.6.3	Mode print . . . . .	110
3.6.4	Setup print . . . . .	111
3.6.5	Palette print . . . . .	112
<b>3.7</b>	<b>Adjust print. . . . .</b>	<b>113</b>
3.7.1	Standard print quality adjustment . . . . .	114
3.7.2	Custom print quality adjustment . . . . .	126
<b>3.8</b>	<b>Connecting the printer to PC . . . . .</b>	<b>145</b>
3.8.1	System requirements. . . . .	145
3.8.2	Preparing cables . . . . .	145
3.8.3	Connecting a network interface cable . . . . .	146
3.8.4	Setting the IP address . . . . .	147
3.8.5	Setting subnet mask . . . . .	150
3.8.6	Gateway setting. . . . .	153
<b>4</b>	<b>Handling the printer</b>	
<b>4.1</b>	<b>Print flow chart. . . . .</b>	<b>158</b>
<b>4.2</b>	<b>Media. . . . .</b>	<b>160</b>
4.2.1	Loadable media . . . . .	160
4.2.2	Cautions on handling media . . . . .	161
4.2.3	Precaution on storing media . . . . .	161
4.2.4	Printing area . . . . .	162
4.2.5	Head height adjustment. . . . .	162
4.2.6	Media feed adjustment . . . . .	164
4.2.7	Installing media holder plates . . . . .	169
<b>4.3</b>	<b>Menu setups on the operation panel . . . . .</b>	<b>172</b>
4.3.1	Panel setup menu overview . . . . .	172
4.3.2	Menu setup procedure. . . . .	173
<b>4.4</b>	<b>Operating from the operation panel. . . . .</b>	<b>176</b>
4.4.1	Feeding media . . . . .	176
4.4.2	Stopping printing operation . . . . .	177
4.4.3	Cutting media . . . . .	178
4.4.4	Changing and confirming settings while printing . . . . .	180
4.4.5	Pausing printing. . . . .	182
4.4.6	Normal Display while Printing . . . . .	183
<b>5</b>	<b>Panel setup menu</b>	
<b>5.1</b>	<b>Sleep mode menu . . . . .</b>	<b>186</b>
5.1.1	Timer Setting menu . . . . .	187
5.1.2	Cleaning Type menu . . . . .	187
5.1.3	Sleep Mode Start menu. . . . .	188

<b>5.2</b>	<b>User Type menu</b> .....	<b>189</b>
5.2.1	Type menu .....	189
5.2.2	Various settings of User type .....	190
<b>5.3</b>	<b>Setup menu</b> .....	<b>208</b>
5.3.1	Side Margin menu .....	210
5.3.2	Take-up menu .....	211
5.3.3	Media loading position .....	212
5.3.4	Origin menu .....	214
5.3.5	Head Travel menu .....	216
5.3.6	Multi Strike count menu .....	216
5.3.7	Slant Check menu .....	219
5.3.8	Auto Cleaning menu .....	219
5.3.9	Roll Length menu .....	223
5.3.10	FrontInterlace Menu .....	224
5.3.11	BottomInterlace menu .....	224
5.3.12	CR Maintenance menu .....	225
5.3.13	Ink Status menu .....	226
5.3.14	Life Times menu .....	227
5.3.15	Header Dump menu .....	228
5.3.16	Exhaust fan menu .....	229
5.3.17	White maintenance menu .....	229
5.3.18	Start Feed menu .....	230
5.3.19	Initialization menu .....	230
5.3.20	Spitting menu .....	231
<b>5.4</b>	<b>TestPrint Menu</b> .....	<b>234</b>
<b>5.5</b>	<b>Cleaning menu</b> .....	<b>235</b>
<b>5.6</b>	<b>Menu Option menu</b> .....	<b>236</b>
<b>5.7</b>	<b>Maintenance menu</b> .....	<b>238</b>
5.7.1	Daily Maintenance menu .....	238
5.7.2	Plug Life menu .....	239
5.7.3	Ink Discharge menu .....	240
<b>5.8</b>	<b>Version menu</b> .....	<b>240</b>
<b>5.9</b>	<b>Initial menu</b> .....	<b>241</b>
5.9.1	Language menu .....	241
5.9.2	Length menu .....	242
5.9.3	IP Address menu .....	242
5.9.4	Subnet Mask menu .....	243
5.9.5	Gateway menu .....	243
5.9.6	Alert Buzzer menu .....	244
<b>5.10</b>	<b>Job Status Menu</b> .....	<b>244</b>
<b>6</b>	<b>Maintenance</b>	
<b>6.1</b>	<b>Wearing the gloves and goggles</b> .....	<b>246</b>
6.1.1	How to wear the supplied gloves .....	246

<b>6.2</b>	<b>Shaking ink cartridges</b> .....	<b>247</b>
<b>6.3</b>	<b>Before using sleep mode for a long time</b> .....	<b>250</b>
<b>6.4</b>	<b>Replacing consumable components</b> .....	<b>251</b>
6.4.1	Replacing ink cartridges .....	251
6.4.2	Replacing roll media .....	257
6.4.3	Replacing the flushing-box sponges .....	260
6.4.4	Replacing the cleaning wiper .....	267
6.4.5	Replacing the Adapter's plug in High-capacity ink pack adapter .....	273
<b>6.5</b>	<b>Cleaning the printer</b> .....	<b>274</b>
6.5.1	Daily Maintenance .....	275
6.5.2	Head cleaning .....	285
6.5.3	Clean daily maintenance parts .....	287
6.5.4	Cleaning the outer case .....	290
6.5.5	Cleaning the inside of the printer .....	290
<b>6.6</b>	<b>Disposal the waste fluids</b> .....	<b>293</b>
<b>6.7</b>	<b>Transporting the printer</b> .....	<b>296</b>
6.7.1	Transporting the printer .....	296
6.7.2	How to carry out initial ink charging after ink discharge .....	297
<b>7</b>	<b>Troubleshooting</b>	
<b>7.1</b>	<b>Malfunctions and failures</b> .....	<b>304</b>
7.1.1	Problems in installation and introduction .....	304
7.1.2	Cannot print at all .....	305
7.1.3	Media-related troubleshooting .....	306
7.1.4	Printing-related troubleshooting .....	309
<b>7.2</b>	<b>Error messages</b> .....	<b>311</b>
7.2.1	Status messages .....	311
7.2.2	Error message display and remedies .....	314
7.2.3	Data error display and solutions .....	317
7.2.4	Command error display and remedies .....	317
7.2.5	Error requiring restart .....	318
<b>7.3</b>	<b>The media is jammed.</b> .....	<b>319</b>
7.3.1	Removing Thick Media .....	319
7.3.2	Removing Roll Media .....	319
<b>8</b>	<b>Appendix</b>	
<b>8.1</b>	<b>Product specifications</b> .....	<b>324</b>
8.1.1	Printer specifications .....	324
<b>8.2</b>	<b>Interface specification</b> .....	<b>326</b>
8.2.1	Network interface specification .....	326
<b>8.3</b>	<b>Options/Supply list</b> .....	<b>327</b>
<b>9</b>	<b>Setup menu diagram</b>	

# 1 Safety instructions

This chapter explains warning terms, safety precautions and warning labels on the product that operators and people who install this product need to know.





- **When installing and operating this printer, be sure to follow the directions and warnings in this book.**
-

## 1.1 Types and meanings of warnings

The warnings in the Operation Manual and the warning labels attached to the printer are categorized into three stages.

Understand the meanings of the following warning terms and follow the contents (instructions) in this manual.

Warning	Meaning
 <b>WARNING</b>	Used for dangerous situations where death or serious injury may be caused.
 <b>CAUTION</b>	Used for dangerous situations that may cause slight or medium injury, or when all or parts of products are damaged.
<b>NOTE</b>	It is used for special cautions and for information that needs to be emphasized.



## 1.2 Important safety instructions

This section explains general cautions that must be followed in order to use this printer safely.

### **WARNING**



Do not install this printer in the following places.  
It may cause an injury if the printer falls down.

- On a shaky stand
- Slanting location
- Place where vibration from other machines is transmitted.



Do not step on this printer or place heavy things on top of it.  
It may cause an injury if the printer falls down.



Do not block the vent by covering the printer with cloths, such as a blanket or tablecloth.  
If the vent is blocked, heat may accumulate inside the printer and it may cause fire.



Do not install the printer where it is humid or dusty.  
It could lead to an electric shock and fire.



Do not use a damaged power cable.  
It could lead to an electric shock and fire.



Do not pull out or insert the power plug with a wet hand.  
This could lead to an electric shock.



Do not connect an earth wire to the following places.

- Gas pipe  
There is a possibility of ignition and explosion.
- Earth wire of telephone cables and lightning rods  
Heavy current might flow whenever lightning strikes.
- Water pipe and faucet  
The earth might not work if a plastic pipe is connected in the middle of the metal pipe.



Do not insert or drop metal or flammable objects into the printer through openings such as a vent.  
It could lead to an electric shock or fire.



If foreign substances or liquids such as water entered the printer, do not use the printer as it is.  
It could lead to an electric shock or fire.  
Immediately turn OFF the power switch, disconnect the power plug from the electric socket, and contact your local MUTOH dealer.



Wire the various cords as directed in the Operation Manual.  
Mistaken wiring could cause fire.



Be sure to use the specified power cord set.  
Using a power cord set other than the specified can cause an electric shock or fire.



Use the power cord set compliant with the safety standards, power-supply voltage, and plug shape of the country where the printer is used.



Use a power cord set which is equipped with a protective earth, and securely connect it to the outlet.



Make sure to use only the specified power supply (AC 100-120 V or AC 200-240 V).  
If a power supply other than the specified voltage is used, it could cause an electric shock and fire.



Take power for the printer directly from the power socket (AC 100-120 V or AC 200-240 V).  
Do not use multiple plugs on the same socket.  
This could generate heat and might cause fire.



Be sure to use a dedicated power socket with earth wire for the power supply, and connect it to the earth wire.  
If the earth wire is not connected, an electric shock or fire may occur.



- The waste fluid from the printer is industrial waste.  
Proper waste fluid disposal according to industrial waste disposal laws and ordinances of your local government is required.  
Consign disposal of waste fluids to a specialized processor.
- Waste fluid from this product is harmful to aquatic organisms. Avoid the waste fluid from out flowing to sewage or natural water systems.

**CAUTION**

The bluish white light that comes from the UV LED equipment is ultraviolet light.  
Ultraviolet light may leak a little from the gaps of the equipment. The level of this ultraviolet light that leaks from the equipment is minimized, but be alert of the following points when handling this product.

- Do not look at the ultraviolet light at close range for a long period of time. This may cause eye damage.
- Do not shine the ultraviolet light on your skin at close range for a long period of time. This may cause skin inflammation.



Pay attention to the following points when handling power cable.

- Do not tamper with the power cable.
- Do not put heavy objects on the power cable.
- Do not bend, twist or pull the power cable by force.
- Do not route the power cable near heating appliances.



Pay attention to the following points when handling the power supply plug.

Any mishandling of the power cable could cause a fire.

- Make sure that no foreign substances such as dust etc. are stuck to the power plug.
- Make sure that the power plug is firmly inserted to the edge of the power socket.



- UV curing ink is harmful to skin. When handling ink cartridges, wear the supplied gloves and make sure that ink does not adhere to your skin. Wear protective glasses and clothes as necessary.  
Skin or eye contact with UV curable ink may cause skin inflammation or allergic reaction.
- If the UV curing ink adheres to your skin, wash with soap and a large amount of water immediately; consult a doctor if an abnormal symptom occurs. If the ink gets in your eyes, wash with a large amount of water and immediately see a doctor.



Do not disassemble the ink cartridges.

If disassembled, there is a possibility that ink might come into contact with eyes or skin.



Do not operate the media loading lever during initial operation and printing.

The print head portion may touch the pressurizing roller portion, and cause a malfunction.



Do not use volatile solvents such as thinner, benzene, or alcohol.

These solvents may cause damage to the printer.



Be careful that no moisture enters the printer.

There is a possibility that the electric circuit inside the printer is short circuited.

















Do not open covers attached using screws under any circumstances.

This may cause an electric shock or a malfunction.



Do not drop waste fluid when replacing the flushing-box sponges.

If waste fluid comes into contact with the grid roller, the surface of the grid roller will be damaged, and the media feed function may be affected.

-  When cleaning the cleaning wiper and around the print head,
  - Do not touch the cleaning wiper and head cap unit.  
Head cleaning may not be performed correctly because of oil from your hands.
  - Do not touch the nozzle of the print head.  
Doing so may damage the print head.
  - Always use a new cleaning stick and dampen it with dedicated maintenance cleaner.
  - DO NOT use non-dedicated maintenance cleaner.  
It may cause nozzle clogging.
-  Do not install this printer in a location that is subject to direct sunlight.  
Otherwise ink may be cured by ultraviolet light in the sunlight.
-  Do not slant the printer, prop it against a wall or turn it upside down.  
There is a possibility that ink inside the printer may leak.  
Moreover, normal operation after shifting (to these positions) cannot be guaranteed.
-  When unpacking and moving the printer to an installation point, be sure to have the following number of personnel.
  - VJ-1626UH: four or more
-  If you have to turn OFF the printer for a long time, unplug the power plug.
-  Make sure to connect an earth wire to the earth connection that meets the following standards.
  - Earth terminal of power socket
  - Earth wire with copper plate which is buried at 650 mm or more, deep in the ground.
-  Before performing work, make sure to read the safety data sheet (SDS).
-  Ventilate the workplace. When using the printer in a poorly-ventilated location, install a ventilation device.  
Otherwise the ink odor may damage your health.
-  Pay attention to the following points when you cut roll media.  
Mishandling the razor blade may cause a cut on your finger or hand.
  - When you hold media, do not place your finger on the media cut groove.
  - Move the razor blade along the media cut groove.
-  Move the printer maintaining a horizontal position.
-  Use the printer with its power turned permanently on. When you are not using the printer, always leave the power on and put the printer into the sleep mode.  
If you do not put the printer into the sleep mode, the ink in its interior could settle out and/or coagulate, causing poor image quality or printer failure.
  - Shake the ink cartridge before use.
  - Shake the ink cartridges periodically.  
Otherwise, the ink inside the cartridges settles or coagulates and may cause poor print quality or a malfunction.
-  If the printer is not going to be used for a long time, first follow the procedure in “[6.3 Before using sleep mode for a long time](#)”.
-  While cleaning the cleaning wiper and the circumference of the print head and the cap, remove the print head cap.  
Do not leave the print head without the cap for a long time.  
This operation should be done within 5 minutes.
-  This product must be protected from chemical agents, corrosive vapors, strong vibration and mechanical impact.
-  Unauthorized dismantling of this product will void all warranty claims.

## 1.3 Warning labels

This section explains the handling of warning label, pasting location and types. Warning labels are attached to parts of the printer that need special caution. Understand the locations and the descriptions of the danger associated with each label before operating the printer.

### 1.3.1 Handling the warning labels

When handling the warning labels, be careful about the following points.

**NOTE**

- Check whether all the warning labels can be read.  
If the letters or illustrations on the label are not clear, remove the dirt from the label.
  - Use cloth, water and mild detergent for removing dirt from the warning label.  
Avoid either organic solvents or gasoline.
  - It is necessary to replace the labels if they are damaged, lost or illegible.  
If the warning labels have to be replaced, contact your local MUTOH dealer.
-

### 1.3.2 Location and type of warning labels





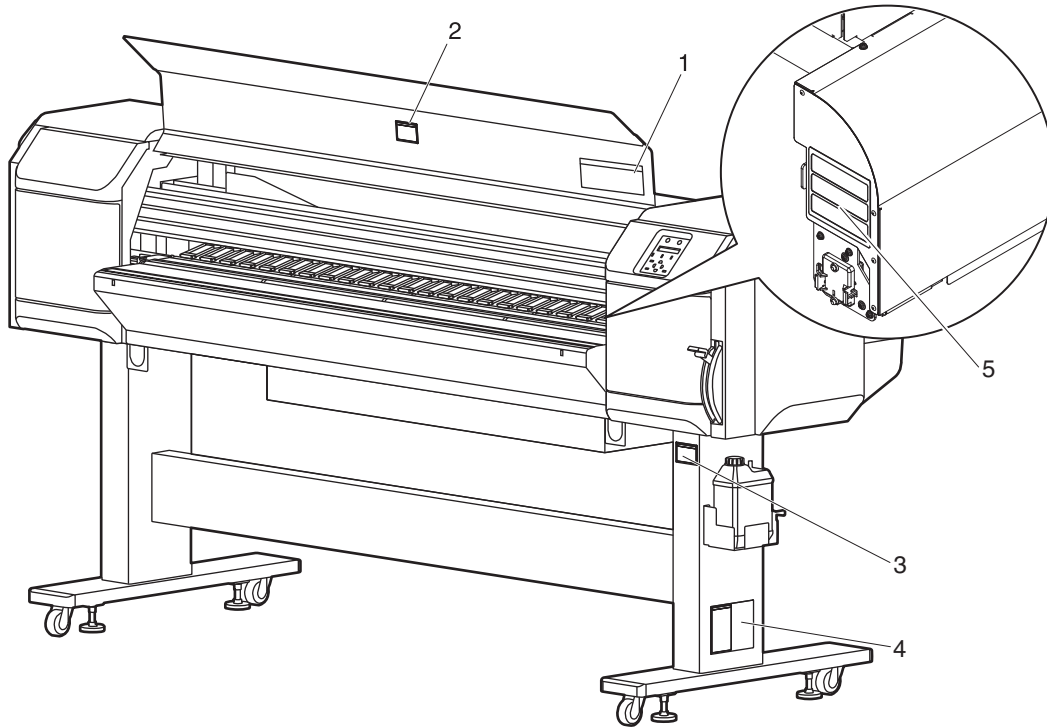

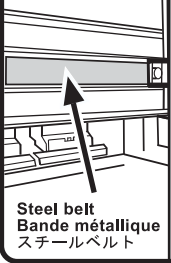

Pasting locations of the warning labels are shown in the following figure.

#### Front side







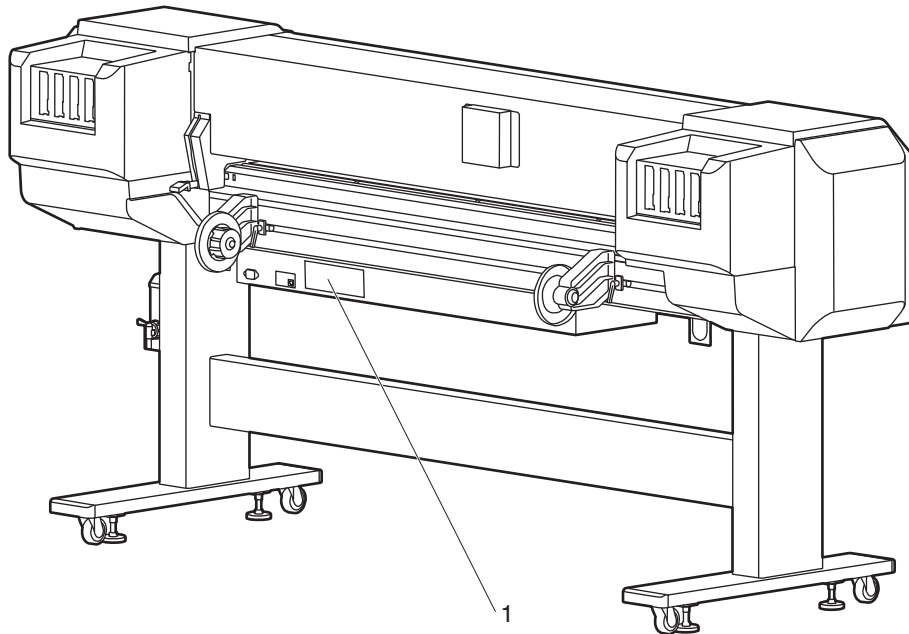

No.	Types of warning labels
1	<div style="border: 2px solid black; padding: 10px;"> <p style="text-align: center;"><b>⚠ CAUTION / ATTENTION / 注意</b></p> <ul style="list-style-type: none"> <li>◆Do not give a direct wind from a fan or air conditioner to the machine. ※A wind may dry the ink in the head nozzles causing clogging that affects ink jetting, and you will not be able to obtain satisfactory printing results.</li> <li>◆Normal cleaning should be done once a week if the printer is not used for a long period. ※If the printer is left without cleaning, the ink will be hardened inside the head nozzle, and may cause the head trouble.</li> <li>◆Do not open the front cover while printing. Moreover, Do not touch the media while printing. Good printing result might not be obtained.</li> <li>◆Please remove the media and hold the lever up when not using for a long time. Due to the environment conditions, media float and wrinkle might happen that does not obtain the good result.</li> <li>◆Paper guides, platen and paper holding plate will become hot due to the heater temperature setting. Beware of being burned.</li> </ul> <hr/> <ul style="list-style-type: none"> <li>◆Ne pas exposer directement l'imprimante aux courants d'air des appareils de ventilation ou de climatisation. ※Un courant d'air peut affecter la projection d'encre, empêchant ainsi l'obtention d'une qualité d'impression satisfaisante; ou entraîner un dysfonctionnement de la tête d'impression, suite à l'assèchement de l'encre à l'intérieur des buses.</li> <li>◆Si vous n'utilisez pas l'imprimante durant une longue période, effectuez un nettoyage normal une fois par semaine.</li> <li>◆Si vous ne le faites pas, cela pourrait entraîner un dysfonctionnement de la tête d'impression, suite à l'assèchement de l'encre à l'intérieur des buses.</li> <li>◆Ne pas ouvrir le capot frontal en cours d'impression. De plus, en cours d'impression, ne pas introduire vos mains par les ouvertures, et ne pas toucher au papier. Vous pourriez vous blesser, ou ne pas obtenir une qualité d'impression satisfaisante.</li> <li>◆Si vous n'imprimez pas durant une longue période, retirez le papier, et maintenez le levier en position haute. A défaut, vous risquez de ne pas obtenir une qualité d'impression satisfaisante.</li> <li>◆Le réglage de la température du chauffe-eau, papier - depuis le guide, platine, papier plaque de pression est une température élevée, il peut provoquer des brûlures.</li> </ul> <hr/> <ul style="list-style-type: none"> <li>◆直接機械に送風機や空調装置の風を当てないで下さい。 ※風によりヘッドノズル内のインクが固まりヘッド故障の原因になったり、インクの吐出に影響を与え、満足な印字結果が得られないことがあります。</li> <li>◆長期間プリンタを使用しない場合は、週に一度ノーマルクリーニングを行ってください。 ※クリーニングを行わずに放置すると、ヘッドノズル内でインクが固まりヘッド故障の原因となります。</li> <li>◆作画中はフロントカバーを開けないでください。また、作画中は開口部から手を入れたり用紙に触れないでください。思わぬケガをしたり、良好な作画結果が得られないことがあります。</li> <li>◆長時間作画を行わない時は、用紙を外しホールドレバーをアップ状態にしてください。良好な作画結果が得られないことがあります。</li> <li>◆ヒーターの温度設定により、ペーパーガイド、プラテン、用紙押えプレートが高温となるため、火傷をする恐れがあります。</li> </ul> </div>

No.	Types of warning labels										
2	<div style="border: 1px solid black; padding: 10px;"> <div style="background-color: yellow; text-align: center; padding: 5px;"> <b>CAUTION / ATTENTION / 注意</b> </div> <div style="display: flex; justify-content: space-between; align-items: flex-start; padding: 10px;"> <div style="width: 30%;">  <p><b>Steel belt</b> <b>Bande métallique</b> スチールベルト</p> </div> <div style="width: 65%;"> <ul style="list-style-type: none"> <li>◆ Sharp Edges. Do not touch steel belt. ※You may be injured.</li> <hr/> <li>◆ Ne pas toucher les bords de la bande métallique, car ceux-ci sont tranchants. ※Vous pourriez vous blesser.</li> <hr/> <li>◆ スチールベルトは端が鋭く尖っていますので触らないでください。 ※けがをする恐れがあります。</li> </ul> </div> </div> </div>										
3	<div style="border: 1px solid black; padding: 10px;"> <div style="background-color: yellow; text-align: center; padding: 5px;"> <b>CAUTION / ATTENTION / 注意</b> </div> <div style="padding: 10px;"> <ul style="list-style-type: none"> <li>◆ Do not bend or pull the waste ink drain tube. The ink may be leaked and damages the printer.</li> <hr/> <li>◆ Ne pas tirer ou plier le drain d'encre usagé; cela pourrait provoquer une fuite d'encre, et endommager l'imprimante.</li> <hr/> <li>◆ 廃液チューブを折り曲げたり、引っ張ったりしないで下さい。インクが漏れて製品が故障する恐れがあります。</li> </ul> </div> </div>										
4	<div style="border: 1px solid black; padding: 10px;"> <div style="display: flex; justify-content: space-between;"> <div style="width: 48%;"> <div style="background-color: yellow; text-align: center; padding: 5px;"> <b>CAUTION / ATTENTION / 注意</b> </div> <ul style="list-style-type: none"> <li>● Before using this product, please be sure to read the Safety Data Sheet. (SDS)</li> <li>● The workplace should be free from open flame and well ventilated.</li> <li>● Please handle the ink with care to avoid the ink touch to your skin, eyes and clothing, also to avoid accidental ingestion. Be careful not to inhale the steam.</li> <li>● Please wear a protective mask, eyewear, gloves, long sleeves and long trousers to avoid contact with the ink during the operation.</li> <li>● Work clothes that soiled with the ink should be thoroughly cleaned.</li> <li>● Please wash your hands and gargle well after using.</li> <li>● Do not bring food near.</li> <li>● Please store out of reach of children.</li> <li>● Do not use for anything other than VJ.</li> </ul> <hr/> <ul style="list-style-type: none"> <li>● Avant utilisation de ce produit, lisez sa fiche de données de sécurité. (SDS)</li> <li>● Veuillez travailler dans un lieu bien ventilé et sans flamme ouverte.</li> <li>● Manipuler l'encre avec précaution, afin qu'il n'entre pas en contact avec la peau, les yeux ou les vêtements, et d'éviter toute ingestion accidentelle. Prendre également garde à ne pas inhaler les vapeurs d'encre.</li> <li>● Pour éviter d'entrer en contact avec l'encre lors de la manipulation, prendre soin de porter un masque, des lunettes et des gants de protection, ainsi que des pantalons et des vêtements aux manches longues.</li> <li>● Les habits de travail tachés par l'encre devront être bien nettoyés.</li> <li>● Après manipulation, bien vous laver les mains et vous rincer la bouche avec soin.</li> <li>● Ne pas amener de la nourriture à proximité.</li> <li>● A conserver hors de portée des enfants.</li> <li>● Ne pas utiliser pour un autre usage que la VJ.</li> </ul> <hr/> <ul style="list-style-type: none"> <li>● ご使用前に、必ず安全データシート (SDS) をお読みください。</li> <li>● 取扱作業場所は火気の無い所で行い、換気を十分に行ってください。</li> <li>● インクを皮膚、目、衣服に接触させたり、誤飲しないよう十分に注意して取扱ってください。また、蒸気を吸込まないよう注意してください。</li> <li>● 取扱中はなるべくインクとの接触を避けるため、保護マスク、保護メガネ、保護手袋、長袖、長ズボン等を着用してください。</li> <li>● 作業衣等に付着した場合は、その汚れをよく落としてください。</li> <li>● 取扱後は、手洗い及びうがいを十分に行ってください。</li> <li>● 食品に近づけないでください。</li> <li>● 子供の手の届かないところへ保管してください。</li> <li>● VJ以外には使用しないでください。</li> </ul> </div> <div style="width: 48%;"> <h3 style="margin-top: 0;">Emergency Measures</h3> <ul style="list-style-type: none"> <li>● If it sticks to your skin, wash well with plenty of soapy water. Consult your doctor if your skin feels irritated or is discolored.</li> <li>● If it gets in your eyes, wash well with plenty of tap water and see your doctor as soon as possible.</li> <li>● If accidentally swallowed, do not vomit. Consult your doctor as soon as possible.</li> <li>● If you inhaled the steam, move to clean air and consult your doctor if you feel giddy or nauseous.</li> <li>● If breathing has stopped, apply artificial respiration immediately, and get an emergency medication.</li> <li>● If spilled from the container, remove heat sources, sparks and flame first, then wipe up with cloth. Used cloths containing ink should be soaked in water until disposal.</li> </ul> <h3 style="margin-top: 10px;">Mesures d'urgence</h3> <ul style="list-style-type: none"> <li>● En cas de contact avec la peau, bien laver et rincer abondamment avec de l'eau savonneuse. Consulter un médecin si la peau est irritée ou si vous constatez une modification de son aspect.</li> <li>● En cas de contact avec les yeux, rincer abondamment avec de l'eau du robinet, et consulter un médecin le plus rapidement possible.</li> <li>● Ne pas régurgiter si vous avez ingéré de l'encre par mégarde. Ne pas régurgiter si vous avez ingéré de l'encre par mégarde.</li> <li>● En cas d'inhalation de vapeurs, déplacez-vous dans un endroit où l'air est propre; consulter un médecin si vous êtes pris de vertiges ou de nausées.</li> <li>● En cas d'arrêt de la respiration, pratiquer immédiatement une ventilation artificielle, et contacter les urgences.</li> <li>● Si l'encre a coulé du réservoir, l'éloigner d'abord des sources de chaleur, des étincelles ou des flammes, puis essuyer avec un morceau de tissu. Toujours laisser tremper les tissus tachés avec de l'encre dans l'eau jusqu'à leur élimination.</li> </ul> <h3 style="margin-top: 10px;">応急処置</h3> <ul style="list-style-type: none"> <li>● 皮膚に付着した場合は多量の水で洗い流し、皮膚に刺激を感じたり変化がある場合は医師の診断を受けてください。</li> <li>● 目に入った場合は多量の水で洗い流し、出来るだけ早く医師の診断を受けてください。</li> <li>● 誤って飲み込んだ場合は吐き出さないでください。その後できるだけ早く医師の診断を受けてください。</li> <li>● 蒸気を吸入した場合は空気の清浄な場所に移動し、めまいや吐き気を感じる場合は医師の診断を受けてください。</li> <li>● 呼吸が止まった場合はただちに人工呼吸を行い、救急医療を受けてください。</li> <li>● 容器からこぼれた場合は、熱源、火花、炎からまず離し、布等で拭き取ってください。インクが付着した布等は廃棄するまで必ず水につけておいてください。</li> </ul> <div style="margin-top: 10px; font-size: x-small;"> <table border="0"> <tr> <td style="padding-right: 5px;">消防法表示</td> <td style="text-align: center;"></td> <td style="text-align: center;"></td> <td style="text-align: center;"></td> <td style="padding-left: 10px;">危険物第四類 第三石油類 水溶性 危険等級III 火気厳禁</td> </tr> <tr> <td></td> <td style="text-align: center;">警告</td> <td style="text-align: center;">引火性</td> <td style="text-align: center;">有毒性</td> <td></td> </tr> </table> </div> </div> </div> </div>	消防法表示				危険物第四類 第三石油類 水溶性 危険等級III 火気厳禁		警告	引火性	有毒性	
消防法表示				危険物第四類 第三石油類 水溶性 危険等級III 火気厳禁							
	警告	引火性	有毒性								

No.	Types of warning labels						
5	<p style="text-align: center;">NOTICE: Minimise exposure to eyes or skin.</p> <div style="text-align: center;"> <table border="1" style="width: 100%; border-collapse: collapse;"> <tr> <td style="width: 20%; padding: 5px;"> <b>Risk Group 2</b>   </td> <td style="padding: 5px;"> <b>WARNING:</b> Use UV radiation eye and skin protection during servicing.  <b>NOTICE:</b> UV emitted from this product. Minimise exposure to eyes or skin. Use appropriate shielding.  <b>CAUTION:</b> UV emitted from this product. Eye or skin irritation may result from exposure. Use appropriate shielding. IEC62471: 2006                 </td> </tr> <tr> <td style="padding: 5px;"> <b>Groupe de risque 2</b>   </td> <td style="padding: 5px;"> <b>Avertissement :</b> Cet appareil émet des rayons ultraviolets. Protégez la peau et les yeux lors de travaux de maintenance.  <b>Avertissement :</b> Cet appareil émet des rayons ultraviolets. Minimisez l'exposition à la peau et aux yeux. Ayez une protection appropriée.  <b>Attention :</b> Ce produit émet des rayons ultraviolets. L'exposition peut provoquer une inflammation de la peau et des yeux. Ayez une protection appropriée. IEC62471: 2006                 </td> </tr> <tr> <td style="padding: 5px;"> <b>リスクグループ2</b>   </td> <td style="padding: 5px;"> <b>警告:</b> この装置は紫外線を放射します。保守作業時には目や皮膚を保護してください。  <b>警告:</b> この装置は紫外線を放射します。目、又は皮膚への暴露を最小限に抑えてください。適切な保護をしてください。  <b>注意:</b> この製品は紫外線を放射します。暴露により目や皮膚に炎症が起こる可能性があります。適切な保護をしてください。 JIS C7550: 2011                 </td> </tr> </table> </div>	<b>Risk Group 2</b> 	<b>WARNING:</b> Use UV radiation eye and skin protection during servicing. <b>NOTICE:</b> UV emitted from this product. Minimise exposure to eyes or skin. Use appropriate shielding. <b>CAUTION:</b> UV emitted from this product. Eye or skin irritation may result from exposure. Use appropriate shielding. IEC62471: 2006	<b>Groupe de risque 2</b> 	<b>Avertissement :</b> Cet appareil émet des rayons ultraviolets. Protégez la peau et les yeux lors de travaux de maintenance. <b>Avertissement :</b> Cet appareil émet des rayons ultraviolets. Minimisez l'exposition à la peau et aux yeux. Ayez une protection appropriée. <b>Attention :</b> Ce produit émet des rayons ultraviolets. L'exposition peut provoquer une inflammation de la peau et des yeux. Ayez une protection appropriée. IEC62471: 2006	<b>リスクグループ2</b> 	<b>警告:</b> この装置は紫外線を放射します。保守作業時には目や皮膚を保護してください。 <b>警告:</b> この装置は紫外線を放射します。目、又は皮膚への暴露を最小限に抑えてください。適切な保護をしてください。 <b>注意:</b> この製品は紫外線を放射します。暴露により目や皮膚に炎症が起こる可能性があります。適切な保護をしてください。 JIS C7550: 2011
<b>Risk Group 2</b> 	<b>WARNING:</b> Use UV radiation eye and skin protection during servicing. <b>NOTICE:</b> UV emitted from this product. Minimise exposure to eyes or skin. Use appropriate shielding. <b>CAUTION:</b> UV emitted from this product. Eye or skin irritation may result from exposure. Use appropriate shielding. IEC62471: 2006						
<b>Groupe de risque 2</b> 	<b>Avertissement :</b> Cet appareil émet des rayons ultraviolets. Protégez la peau et les yeux lors de travaux de maintenance. <b>Avertissement :</b> Cet appareil émet des rayons ultraviolets. Minimisez l'exposition à la peau et aux yeux. Ayez une protection appropriée. <b>Attention :</b> Ce produit émet des rayons ultraviolets. L'exposition peut provoquer une inflammation de la peau et des yeux. Ayez une protection appropriée. IEC62471: 2006						
<b>リスクグループ2</b> 	<b>警告:</b> この装置は紫外線を放射します。保守作業時には目や皮膚を保護してください。 <b>警告:</b> この装置は紫外線を放射します。目、又は皮膚への暴露を最小限に抑えてください。適切な保護をしてください。 <b>注意:</b> この製品は紫外線を放射します。暴露により目や皮膚に炎症が起こる可能性があります。適切な保護をしてください。 JIS C7550: 2011						

Rear side



No.	Types of warning labels
1	<div style="border: 1px solid black; padding: 10px;"> <div style="display: flex; justify-content: space-between;"> <div style="width: 30%;"> <p><b>MUTOH</b></p> <p>MODEL 型式 VJ-1626UH</p> <p>SERIAL NO. 製造番号 HE6U*****</p> <p>Complies With UL 60950-1 CSA C22.2 No. 60950-1 E112544</p> <p>  </p> </div> <div style="width: 30%;"> <p>VOLTAGE AC 100-240V</p> <p>FREQUENCY 50 / 60 Hz</p> <p>CURRENT 4.0A - 2.0A</p> </div> <div style="width: 30%;"> <p>This device complies with Part 15 of the FCC Rules. Operation is subject to the following two conditions: (1) this device may not cause harmful interference, and (2) this device must accept any interference received, including interference that may cause undesired operation.</p> <p>This Class A digital apparatus complies with Canadian ICES-003. Cet appareil numérique de la classe A est conforme à la norme NMB-003 du Canada.</p> <p>MUTOH INDUSTRIES LTD. MADE IN JAPAN</p> </div> </div> <div style="margin-top: 10px; border: 1px solid black; padding: 5px; width: fit-content; margin-left: auto; margin-right: auto;"> <p>定格電圧 AC 100V 定格周波数 50 / 60 Hz 消費電流 4.0A</p> </div> <div style="margin-top: 10px;"> <p><b>注意</b></p> <p>この装置は、クラスA情報技術装置です。この装置を家庭環境で使用すると電波妨害を引き起こすことがあります。この場合には使用者が適切な対策を講ずるよう要求されることがあります。</p> <p style="text-align: right;">VOC1-A 武藤工業株式会社 MADE IN JAPAN</p> </div> <div style="margin-top: 10px; display: flex; justify-content: space-between;"> <div style="width: 45%; border: 1px solid black; padding: 5px;"> <ul style="list-style-type: none"> <li>• Apparatet må tilkoples jordet stikkontakt</li> <li>• Apparatet skal anslutas till jordat uttag</li> <li>• Laite on liitettävä suojakosketinilla varustettuun pistorasiaan</li> <li>• Apparatets stikprop skal tilsluttes en stikkontakt med jord, som giver forbindelse til stikproppens jord</li> </ul> </div> <div style="width: 45%; border: 1px solid black; padding: 5px;"> <p> 仅适用于海拔 2000m 以下地区安全使用。</p> <p> 仅适用于非热带气候条件下安全使用。</p> </div> </div> </div>







## 2 Product overview

This chapter explains the features of this printer along with the names and functions of each part.

## 2.1 Features

This section explains the main features of the printer.

### (1) Adopting UV curing ink

UV curing ink (Ultraviolet curable ink) has improved the operability as it is cured and fixated immediately after printing. Ink fixation on various materials has also improved.

### (2) Supporting thick media

Height adjustment mechanism of the print head now supports rigid media\*1 of up to a thickness of 15.0 mm.

A wide variety of media of a thickness of 0.08 mm to 15.0 mm is supported.

\*1 : Hard media such as a board is described as “rigid media” in this manual.

### (3) Supporting hard media

Rubber rollers adopted in the feeding mechanism have realized feeding rigid media such as glass.

### (4) Improved color development and supporting special printing

White ink and varnish (clear top coat) supported (when using 6 colors). Using white ink as the base (under layer) when printing on transparent media or colored material improves color development (Layer printing depends on the function of the RIP software you are using).

White ink printing is thicker than other colors as twice the amount of nozzles are used for white ink. Layering varnish (over layer) creates a glossy finish and thick printing.

### (5) LED pointer embedded

Embedded LED pointer has made it easy to change the origin point for printing. By saving the changed origin position, it has also been made easy to print on the same position repeatedly.

### (6) Improved Media-feed table functions (optional)

Embedded rollers in Media-feed table have improved the feeding accuracy for rigid media.

## 2.2 Names of parts and functions

This section explains the names and functions of each part.

### 2.2.1 Front section

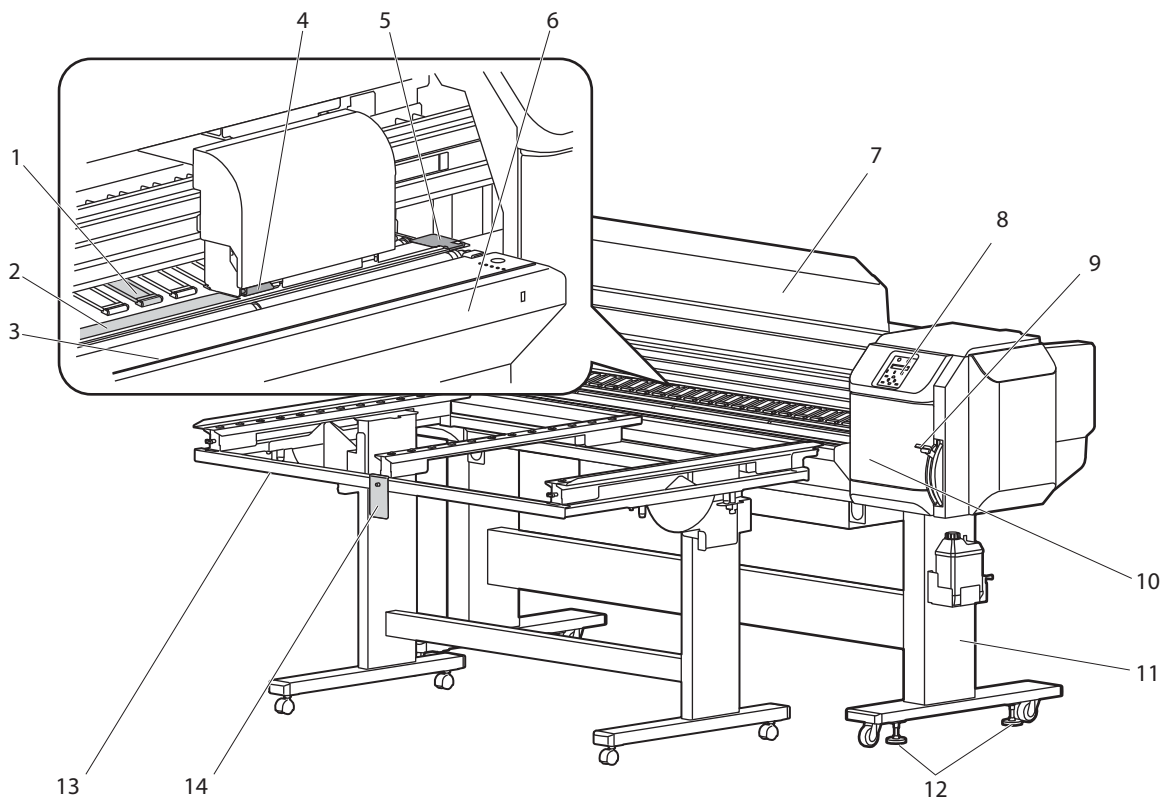

No.	Name	Function
1	Pressurizing rollers	Installed inside of the front cover. Press and hold the media when printing.
2	Platen	Installed inside of Front cover. Holds the media from the bottom during printing.
3	Media cut groove	Installed inside of the front cover. Used to cut media straight.
4	UV LED part	Emits ultraviolet ray and cures the ink. Lights during printing.
5	Media holder plate	Installed inside of Front cover. Attach them to the both edges of the media to minimize warpage of thin media such as roll media (with a thickness of less than 0.5 mm) to a degree.
6	Media guide	Used for feeding media smoothly when the media is set or printed. The heater (drier) to dry ink is installed.

No.	Name	Function
7	Front cover	Used for preventing a user from coming in contact with the driving mechanism during the printer operation. Opened and closed when media is set or jammed. It is normally closed.
8	Printer operation panel	Operation condition setting, printer display and various function settings are performed.  <a href="#">2.2.3 Operation panel</a>
9	Front media loading lever	Used for fixing or releasing the media. The operation is the opposite of Rear media loading lever on the rear side of the printer. <ul style="list-style-type: none"> <li>• Lower Lever to fix the media.</li> <li>• Raise Lever to release the media.</li> </ul>
10	Maintenance cover	Used to prevent the user from touching the inner mechanical section. Open and close in the following cases. <ul style="list-style-type: none"> <li>• When cleaning the cleaning wiper unit</li> <li>• When cleaning around the print head</li> <li>• When performing CR maintenance</li> </ul> It is normally closed.
11	Stand	Used when installing the printer on a flat floor.
12	Adjuster	Used to install the printer horizontally.
13	Media-feed table	Used for feeding thick media smoothly. Remove it when using roll media.
14	Media stopper	If the media you placed on Media-feed table slides down forward, loosen the lug screw and move Stopper upward. Stopper should normally be facing down.

 **CAUTION**

- **The bluish white light that comes from the UV LED equipment is ultraviolet light. Ultraviolet light may leak a little from the gaps of the equipment. The level of this ultraviolet light that leaks from the equipment is minimized, but be alert of the following points when handling this product.**
  - **Do not look at the ultraviolet light at close range for a long period of time. This may cause eye damage.**
  - **Do not shine the ultraviolet light on your skin at close range for a long period of time. This may cause skin inflammation.**

## 2.2.2 Rear section

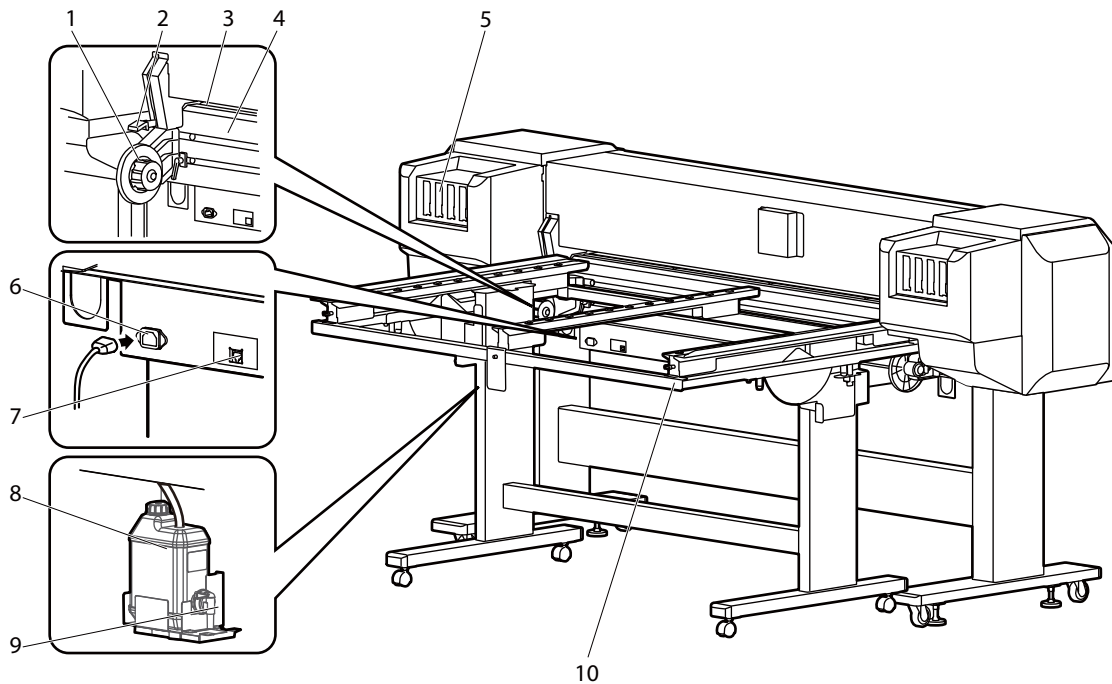

No.	Name	Function
1	Roll media holders	Used to load the roll media. Include flanges where roll media is attached, and the levers that fix the roll media holders.
2	Rear media loading lever	Used for fixing or releasing the media. The operation is the opposite of Front media loading lever on the front of the printer. <ul style="list-style-type: none"> <li>• Lower Lever to release the media.</li> <li>• Raise Lever to fix the media.</li> </ul>
3	Media feed slot	Used for feeding media.
4	Media guide	Used for feeding media smoothly when the media is set or printed. The heater (pre heater) to warm media is installed.
5	Ink cartridge slots	Install ink cartridges.
6	AC inlet for the printer	Used for connecting the power cable.
7	Network interface connector	Connects a network interface cable.
8	Waste fluid tank	Used for collecting waste ink discharged from the printer.
9	Waste fluid valve	Open and close when discharging the waste fluid from the waste fluid tank. It is normally closed.
10	Media-feed table (optional)	Used for feeding thick media smoothly. Remove it when using roll media.

### 2.2.3 Operation panel

Used for setting operation conditions, display of printer status and various functions. Names of each operation key (Switch) and status display along with the functions are explained.

**TIP**

- Refer to the following for details regarding the operation method.
- When performing menu setting from the printer operation panel: [4.3 Menu setups on the operation panel](#)
- When performing various operations in the printer operation panel: [4.4 Operating from the operation panel](#)

#### 2.2.3.1 Printer operation panel

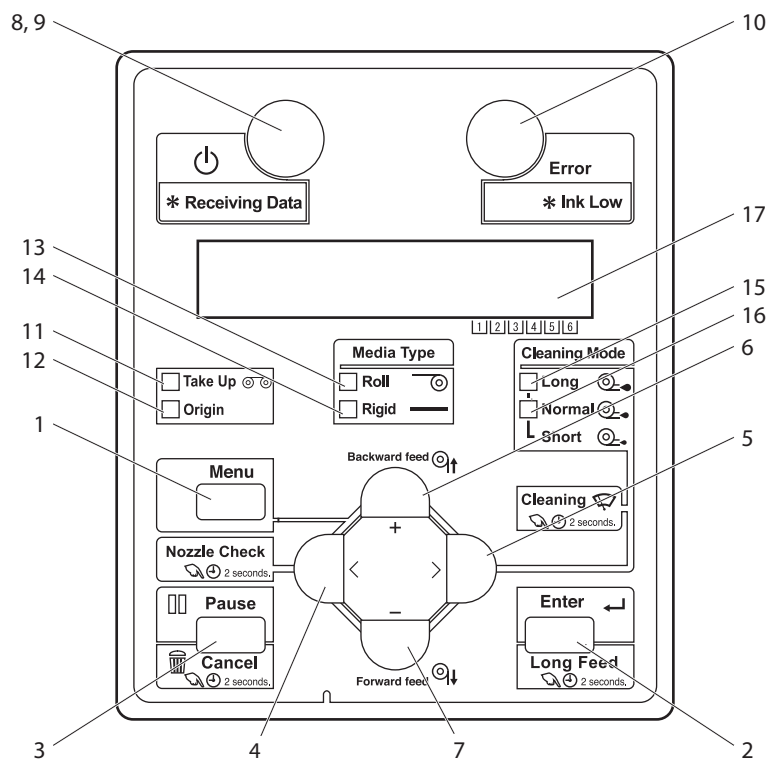



## (1) Operation keys

### NOTE

- The operation keys are assigned with different functions and names depending on printer status (Normal or Setup menu display).  
For details about printer status, refer to “[2.3 Printer status](#)”.
- The  symbol means “standby”. Even when the power button is not turned on, the printer consumes a tiny amount of power so long as the power cable is connected. This state is referred to as the power being “off” in this Manual.

No.	Name	Normal	Setup menu display
1	[Menu] key	Shifts to the Setup menu.	Shifts from Setup menu display to Normal.
2	[Enter] key	Restarts printing when the printing is suspended.	<ul style="list-style-type: none"> <li>• Select the menu to be set, and shifts to the next hierarchy.</li> <li>• The setting is determined and saved.</li> </ul>
	[Long Feed] key	Feeds a specified amount of media when pressed for more than two seconds.	—
3	[Pause] key	Pauses printing.	—
	[Cancel] key	Press and hold this key for more than two seconds to do the following operations: <ul style="list-style-type: none"> <li>• When printing: Forcefully terminates printing and deletes one file of the remaining data.</li> <li>• When receiving or analyzing: Deletes data that are already received and analyzed, and delete the next data.</li> </ul>	<ul style="list-style-type: none"> <li>• Returns to the previous menu hierarchy. Changes made in the setting are discarded.</li> <li>• Shifts from Setup menu display to Normal.</li> </ul>
4	[<] key	—	Changes the set value.
	[Nozzle Check] key	Press and hold this key for two seconds or more to perform Nozzle Check printing.	—
5	[>] key	Sets Cleaning Mode. <ul style="list-style-type: none"> <li>• The lamp of Cleaning Mode that you set lights up in green.</li> </ul>	<ul style="list-style-type: none"> <li>• Down the menu level in the directory tree.</li> <li>• Changes the set value.</li> </ul>
6	[Backward↑] key	Media is fed in the reverse direction.	—
	[+] key	—	<ul style="list-style-type: none"> <li>• Changes to the previous item in the displayed menu.</li> <li>• The setting is changed to the forward direction.</li> <li>• The numeric value is increased during numerical input.</li> </ul>
7	[Forward↓] key	Media is fed in the forward direction.	—
	[-] key	—	<ul style="list-style-type: none"> <li>• Changes to the previous item in the displayed setting.</li> <li>• The setting is changed to the reverse direction.</li> <li>• The numeric value is decreased during numerical input.</li> </ul>
8	[Power] key	Turns the printer ON and OFF.	Turns the printer ON and OFF.

**(2) Display section**

No.	Name	Color	Status	Description
9	Power lamp	Blue	Lamp ON	Power ON.
			Lamp blinks	<ul style="list-style-type: none"> <li>Data is received and analyzed.</li> <li>Performing media initial operation.</li> </ul>
			Flashes every 5 sec.	<ul style="list-style-type: none"> <li>In Sleep Mode</li> </ul>
			Lamp OFF	Power OFF.
10	Error lamp	Orange	Lamp ON	<ul style="list-style-type: none"> <li>An error has occurred.</li> <li>The error content is displayed on the LCD.</li> </ul>
			Lamp blinks	The remaining amount of ink is low.
			Lamp OFF	There is no error.
11	Take up lamp	Green	Lamp ON	“Take-up setting” is enabled.
			Lamp OFF	“Take-up setting” is disabled.
12	Origin lamp	Green	Lamp ON	“Origin” is activated.
			Lamp OFF	“Origin” is deactivated.
13	Roll lamp	Green	Lamp ON	Media type is set as “Roll media”.
14	Rigid lamp	Green	Lamp ON	Media type is set as “Rigid”.
15	Long lamp	Green	Lamp ON	<ul style="list-style-type: none"> <li>Cleaning Mode is set to Long.</li> <li>When the Normal lamp is also turned on, Cleaning Mode is set to Short.</li> </ul>
			Lamp OFF	Cleaning Mode is set to Normal.
16	Normal lamp	Green	Lamp ON	<ul style="list-style-type: none"> <li>Cleaning Mode is set to Normal.</li> <li>When the Long lamp is also turned on, Cleaning Mode is set to Short.</li> </ul>
			Lamp OFF	Cleaning Mode is set to Long.
17	LCD display section	—	—	Displays operation status of the printer or an error message.

**TIP**

•When an error requiring a restart (fatal malfunction for the printer operation) occurs, all lamps blink with an alarm.

 [7.2.5 Error requiring restart](#)

•If the error persists even when the malfunction is fixed, contact your local MUTOH dealer.

## 2.2.4 Indicator display

Indicator to indicate the status of the ink or cartridges is displayed on the LED panel in the following situations:

- In the Normal operation  
[☞ 2.3.2 Normal](#)
- During printing
- To display ink or cartridge errors  
[☞ 7.2.2 Error message display and remedies](#)

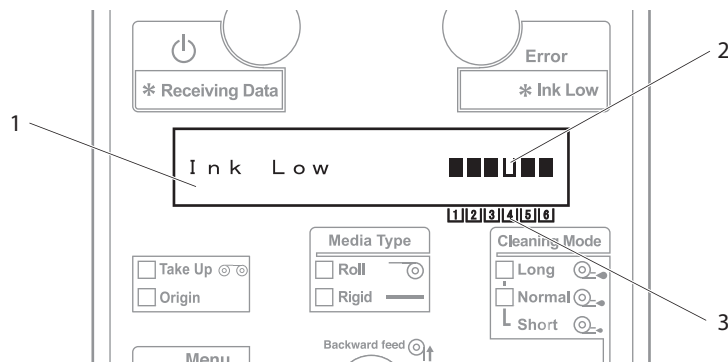

No.	Name
1	LCD display section
2	Indicator
3	Slot No.

Slot numbers for the ink cartridges are printed under the indicator, showing the following colors.

**For six colors:**











Slot No.	Ink color
1	Black (K)
2	Magenta (M)
3	Cyan (C)
4	Yellow (Y)
5	Varnish (VA)
6	White (WH)

**For four colors:**



Slot No.	Ink color
1	Magenta (M)
2	Magenta (M)
3	Cyan (C)
4	Cyan (C)
5	Black (K)
6	Yellow (Y)

### 2.2.4.1 Estimated Ink level graphic

No.	Indicator to display	the conditions of ink/cartridges
1		Remaining ink amount : More than 80%, less than 100%
2		Remaining ink amount : More than 60%, less than 80%
3		Remaining ink amount : More than 40%, less than 60%
4		Remaining ink amount : More than 20%, less than 40%
5		Remaining ink amount : Less than 20%
6		Ink Near End
7		Ink End
8		No cartridge

## 2.3 Printer status

This chapter explains printer status.

### 2.3.1 Number of colors to be used

You can select the number of ink colors to set to this printer at the time of initial ink charging. Each ink set has the following features:

- 4-color set: you can print faster than when using the 6-color set ink.
- 6-color set: White ink and varnish (clear top coat) are available.  
Using white ink as the base (under layer) when printing on transparent media or colored material improves color development (Layer printing depends on the function of the RIP software you are using). Layering varnish (over layer) creates a glossy finish and thick printing.



#### CAUTION

- **The pigment of the ink for this printer tends to settle. To perform stable printing, you need to perform ink circulation inside the printer, as well as regular Head cleaning. While in sleep mode, ink circulation and Head cleaning are performed automatically; therefore, set the printer in sleep mode at the end of work.**
  - **Shake the ink cartridge before use.**
  - **Shake the ink cartridges periodically. Otherwise, the ink inside the cartridges settles or coagulates and may cause poor print quality or a malfunction.**
- 

### 2.3.2 Normal

Printing is possible when media is loaded.  
The various functions for printing can be performed.

### 2.3.3 Setup menu display

Various settings regarding printing can be made from the operation panel.  
The various functions for printing can be performed.  
Display contents in the LCD monitor are as follows.

## 2.3.4 Changing printer status

Follow the procedure below and change printer status.

### (1) Normal → Setup menu display

Press the [Menu] key when the printer is Normal.

- “Menu 1: Sleep Mode>” is displayed and shifts to the Setup menu.

#### NOTE

For details regarding the Setup menu, refer to “[4.3 Menu setups on the operation panel](#)”.

### (2) Setup menu display → Normal

When the printer is at the Setup menu display, perform either of the following operations to shift the operation panel to the Normal display.

- Press the [Cancel] key.
- In the Setup menu, leave the keys untouched for three minutes.

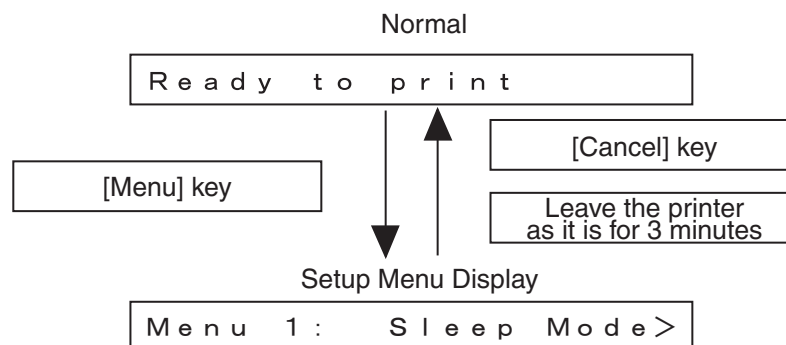

#### NOTE

- When the CR maintenance menu is displayed, even leaving the keys untouched for three minutes does not return to the printer to normal status.  
[🔗 5.3.12 CR Maintenance menu](#)
- For details on Status messages, refer to “[7.2.1 Status messages](#)”.





## 3 Before using

This chapter explains necessary steps before using the printer.

## 3.1 Power cable connection

This section explains power cable connection.

### WARNING

- **Be sure to use the power cable supplied with the printer.**  
Using other power cables can cause an electric shock or fire.
- **Use the power cord set compliant with the safety standards, power-supply voltage, and plug shape of the country where the printer is used.**
- **Use a power cord set which is equipped with a protective earth, and securely connect it to the outlet.**
- **Do not use a damaged power cable.**  
It could lead to an electric shock and fire.

### CAUTION

- **Pay attention to the following points when handling power cable.**
  - **Do not tamper with the power cable.**
  - **Do not put heavy objects on the power cable.**
  - **Do not bend, twist or pull the power cable by force.**
  - **Do not route the power cable near heating appliances.**

### NOTE

- Contact your local MUTOH dealer in case of power cable damage.
- This product is also designed for IT power distribution system with phase-to-phase voltage 230V.

Follow the procedure below to install the power cable.

1. Make sure that the printer is turned OFF.

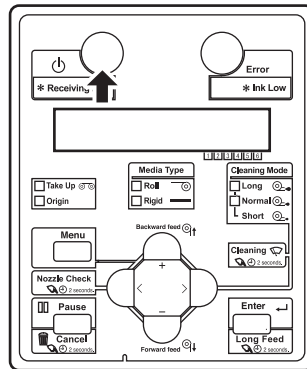

**NOTE**

The power is ON when the [Power] key is pressed in.  
Press the key once again to turn OFF the power.

2. Connect the power cables to the AC inlets on the rear side of the product.

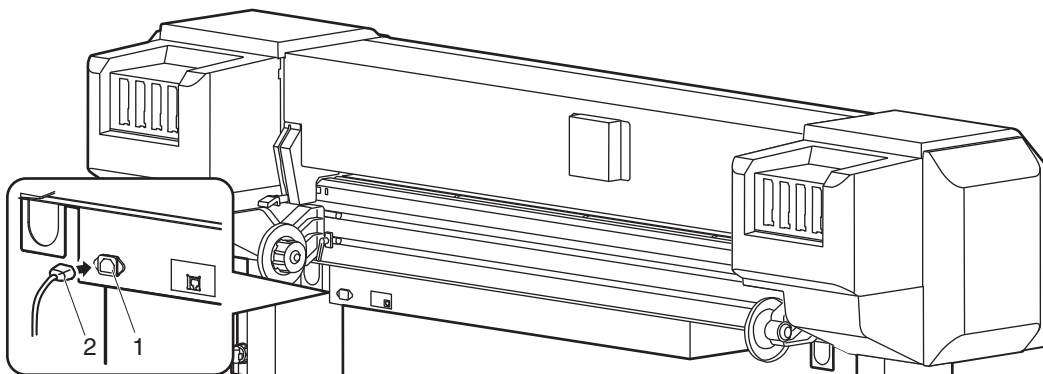

No.	Name
1	AC inlet
2	Power cable

3. Insert the power cable plug firmly in the socket.

**⚠ WARNING**

- **Do not pull out or insert the power plug with a wet hand.**  
This could lead to an electric shock.
- **Make sure to use only the specified power supply (AC 100-120 V or AC 200-240 V).**  
If a power supply other than the specified voltage is used, it could cause an electric shock and fire.
- **Take power for the printer directly from the power socket (AC 100-120 V or AC 200-240 V).**  
Do not use multiple plugs on the same socket.  
This could generate heat and might cause fire.
- **Be sure to use a dedicated power socket with earth wire for the power supply, and connect it to the earth wire.**  
If the earth wire is not connected, an electric shock or fire may occur.
- **Do not connect an earth wire to the following places.**
  - **Gas pipe**  
There is a possibility of ignition and explosion.
  - **Earth wire of telephone cables and lightning rods**  
Heavy current might flow whenever lightning strikes.
  - **Water pipe and faucet**  
The earth might not work if a plastic pipe is connected in the middle of the metal pipe.

**⚠ CAUTION**

- **Pay attention to the following points when handling the power supply plug.**  
Any mishandling of the power cable could cause a fire.
  - **Make sure that no foreign substances such as dust etc. are stuck to the power plug.**
  - **Make sure that the power plug is firmly inserted to the edge of the power socket.**
  - **When you do not use the printer for a long period, make sure to pull out the power plug from the power socket for safety.**
- **If you are leaving the printer unplugged for a long time, unplug the power plug.**
- **Make sure to connect an earth wire to the earth connection that meets the following standards.**
  - **Earth terminal of power socket**
  - **Earth wire with copper plate which is buried at 650 mm or more, deep in the ground.**

**NOTE**

- Contact the retail outlet of purchase if the earth connection cannot be established, or if the earth connection is not given.
- When the power supply of the printer is ON, do not pull out the power cable from the power socket. Whenever the plug is pulled out from the power socket, allow one minute or more before inserting the plug in the power socket again.

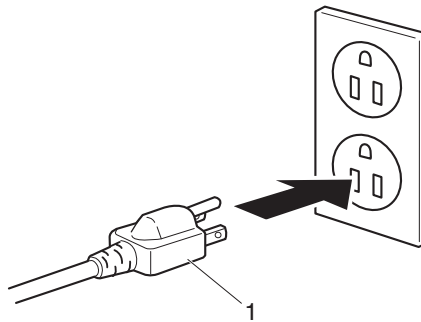

No.	Name
1	Power plug

## 3.2 Turning the power ON/OFF

This section explains how to turn the printer ON/OFF.

### 3.2.1 Turning the power ON

Follow the procedure below to turn the power ON.

1. Press the [Power] key to turn ON the printer.
  - The Power lamp lights up in blue.
  - The printer starts initial operation.
  - When the initial operation is complete, the printer enters Normal.

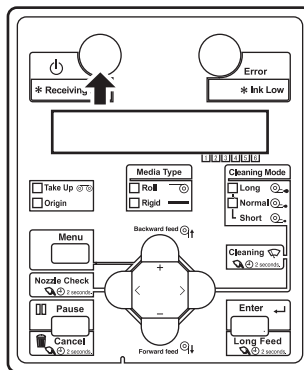

#### NOTE

If there is a problem during the initial operation, a message is displayed and the printer may stop operating.

If operation stops, refer to “7 Troubleshooting” and deal with the problem.

### 3.2.2 Turning the power OFF



#### WARNING

- Use the printer with its power turned permanently on. When you are not using the printer, always leave the power on and put the printer into the sleep mode. If you do not put the printer into the sleep mode, the ink in its interior could settle out and/or coagulate, causing poor image quality or printer failure.

[3.3 Sleep mode](#)

1. Make sure that the printer's operating condition is as follows:
  - Printing or other operation is not in progress.
  - Operation panel display is in the Normal condition.
2. Prepare items required for daily maintenance.
 

[Preparing for Daily Maintenance](#)
3. Press the [Power] key.

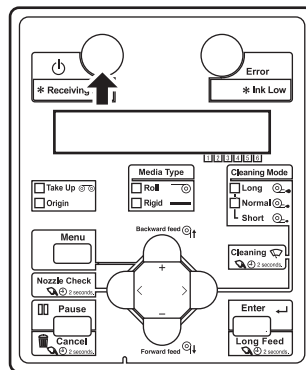

4. "Daily Maint.: Start" is displayed.
  - Press the [Enter] key.

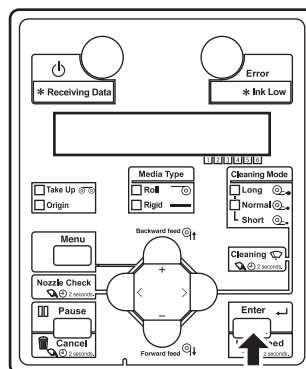

- The carriage and cleaning wiper move to the maintenance position.
- "Daily Maint.: End" is displayed.

5. You can start daily maintenance.

 [Performing Daily Maintenance](#)

6. After the daily maintenance is complete, press the [Enter] key.

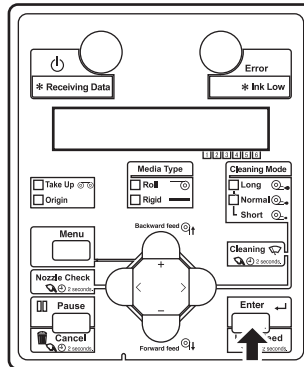

- The printer moves the carriage and the cleaning wiper back to each original position.
- The printer automatically performs the “Short” cleaning.

7. After the “Short” cleaning, “Wait for a while” is displayed.

- The printer starts its powering off operations.
- All lamps and the LCD monitor turn OFF.
- Power is turned OFF.



### 3.3 Sleep mode

If you set the printer's sleep mode, the printer performs the following operation.

- Vacuum fan stops.
- All Lamps turn off except for Power lamp.
- Automatic Head cleaning is performed after the time set in the Timer Setting Menu has elapsed.  
[🔗 5.1.1 Timer Setting menu](#)
- Ink circulation
- Performs “Little Charge”

Because this minimizes the operation, you can reduce power consumption.

#### CAUTION

- **Use the printer with its power turned permanently on. When you are not using the printer, always leave the power on and put the printer into the sleep mode. If you do not put the printer into the sleep mode, the ink in its interior could settle out and/or coagulate, causing poor image quality or printer failure.**

- If you expect keeping the sleep mode for a long time, first follow the procedure in “[6.3 Before using sleep mode for a long time](#)”.

### 3.3.1 Set sleep mode on the printer

- Make sure that the printer's operating condition is as follows:
  - Printing or other operation is not in progress.
  - Operation panel display is in the Normal condition.
  - There is ample amount of ink in the ink cartridges.
    - ☞ [5.3.13 Ink Status menu](#)
    - ☞ [6.4.1 Replacing ink cartridges](#)
  - There is enough free space in the waste fluid bottle.
    - ☞ [6.6 Disposal the waste fluids](#)
  - Front cover is closed.
- Prepare items required for daily maintenance.
  - ☞ [Preparing for Daily Maintenance](#)
- Press the [Menu] key.

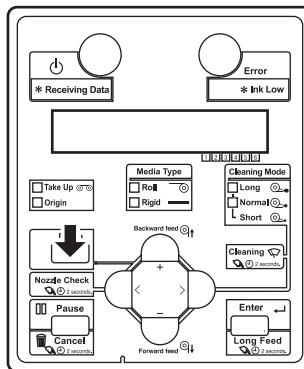

- “Menu1: Sleep Mode>” is displayed.

- Press the [>] key.

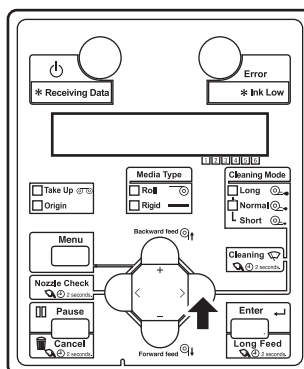

- “Sleep Mode1: Set Timer” is displayed.

**NOTE**

Set the Head cleaning interval while the printer is in Sleep Mode. If it has already been set, proceed to step 7.

5. Press the [Enter] key.

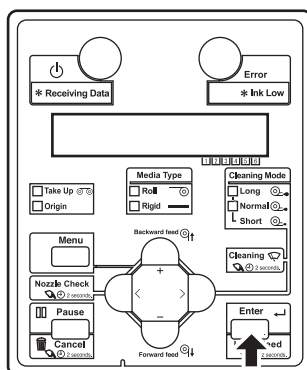

- “CleaningTimer: Off” is displayed.

6. Use the [+] or [-] key to select the Head cleaning interval.

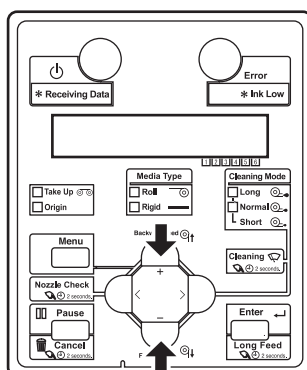

- For the Head cleaning intervals, select from the following.  
When more than the set time has passed, Print head is cleaned automatically.
  - Off: Head cleaning is not performed.
  - 1 to 6/9/12/18/24h: Head cleaning is performed at a set interval of time.

**NOTE**

Even when the timer is set to Off, “LittleCharge” is automatically performed. Also, when using the 6-color set, cleaning and flushing are automatically performed when the sleep mode is cancelled.

This is for maintaining the print head and ink.

7. Press the [Enter] key.

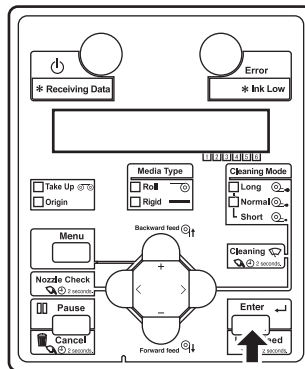

- The timer has been set.
- “Sleep Mode1: Set Timer” is displayed.

8. Use the [+] or [-] key to select “Sleep Mode2: Type”.

- “Type: Short” is displayed.

9. Use the [+] or [-] key to select the cleaning mode while in sleep mode.

- “Short”: Discharges smaller amount of ink compared to “Normal”.
- “Normal”: Select this mode normally.
- “Long”: Discharges a larger amount of ink compare to “Normal”.  
Use this when “Normal” Head cleaning cannot improve the problem of the Print head.

10. Press the [Enter] key.

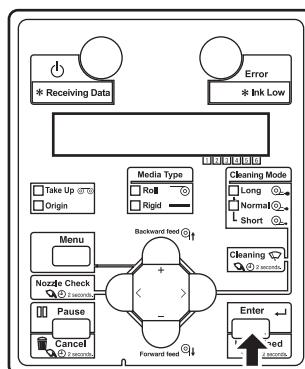

11. Use the [+] or [-] key to select “Sleep Mode3: Start”.

- “Start Sleep Mode?” is displayed.

12. Press the [Enter] key.

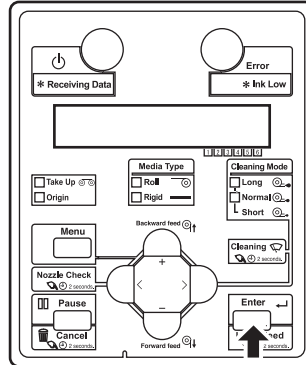

13. “Daily Maint.: Start” is displayed.

- Press the [Enter] key.

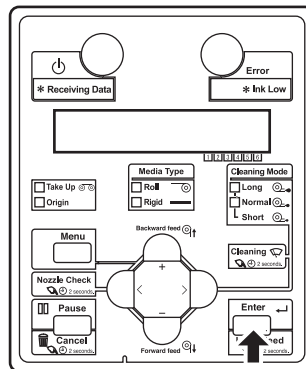

- The carriage and cleaning wiper move to the maintenance position.
- “Daily Maint.: End” is displayed.

14. You can start daily maintenance.

 [Performing Daily Maintenance](#)

15. After the daily maintenance is complete, press the [Enter] key.

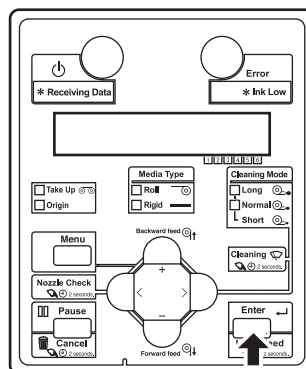

- The printer moves the carriage and the cleaning wiper back to each original position.
- The printer automatically performs the “Short” cleaning.
- “Restart -> Enter” is displayed.
- The printer goes into sleep mode.

**NOTE**

- If you press the [Enter] key during sleep mode, the printer returns to the Normal condition.
- If the printer is under one of the following conditions while shifting to sleep mode, “Don’tStart SleepMode” is displayed, and sleep mode does not start.
  - Front cover or Maintenance cover is open.
  - Waste fluid tank is full.
  - There is little remaining ink in the ink cartridge (or no ink)
  - Ink cartridge has been removed.
  - An ink cartridge other than genuine ink cartridge is inserted into Cartridge slot, etc.

Activate Sleep Mode again after returning the printer to a normal state.

 [7.2 Error messages](#)

- If the printer is under one of the conditions above during sleep mode, the printer will not return to the Normal condition even after pressing the [Enter] key.  
Make sure that everything is as it should be, and press the [Enter] key to return the printer to the normal condition.

 [7.2 Error messages](#)

---

### 3.3.2 Recover the printer from sleep mode

1. Press the [Enter] key.

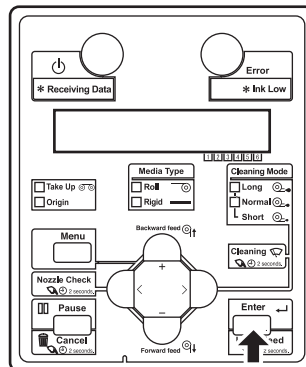

- The printer returns to the Normal condition.

## 3.4 Initial ink charging

Head cleaning and the initial ink charging are required before you use this printer.

### NOTE

This operation takes about 33 minutes (excluding the time to remove or attach the ink cartridges).

Follow the procedure below to perform initial ink charging.

### WARNING

- **UV curing ink is harmful to skin. When handling ink cartridges, wear the supplied gloves and make sure that ink does not adhere to your skin. Wear protective glasses and clothes as necessary. Skin or eye contact with UV curable ink may cause skin inflammation or allergic reaction.**
- **If the UV curing ink adheres to your skin, wash with soap and a large amount of water immediately; consult a doctor if an abnormal symptom occurs.**
- **If the ink gets in your eyes, wash with a large amount of water and immediately see a doctor.**
- **When removing the ink cartridges from the printer for a long period of time, put them into the original packages, or store them in a location where light is completely blocked. Otherwise ink quality may change.**

1. Turn the printer ON.
  - The printer starts the initializing operation.
  - After the initial operation is complete, “Installed Wiper? No” is displayed.
2. Open Maintenance cover on the right side of the printer.

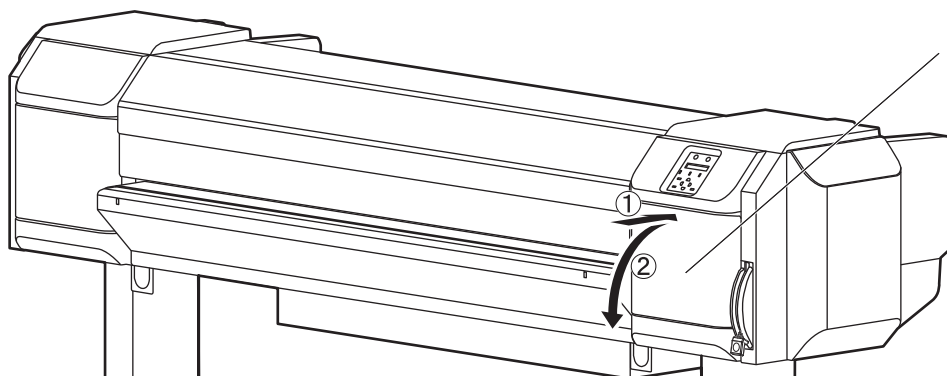

No.	Name
1	Maintenance cover



3. Follow the steps below to install cleaning wiper.

- Slide the rear side of the cleaning wiper into its slot.
- Press the wiper hook down until it clicks into place.

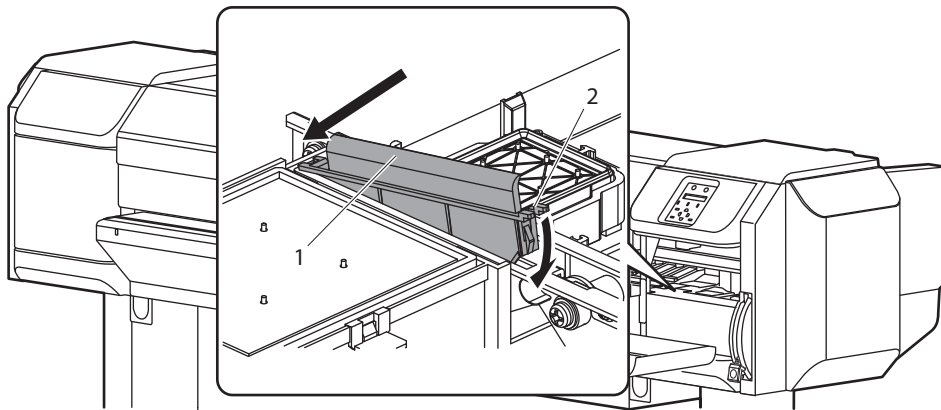

No.	Name
1	Cleaning wiper
2	Cleaning wiper hook

4. Close the maintenance cover.

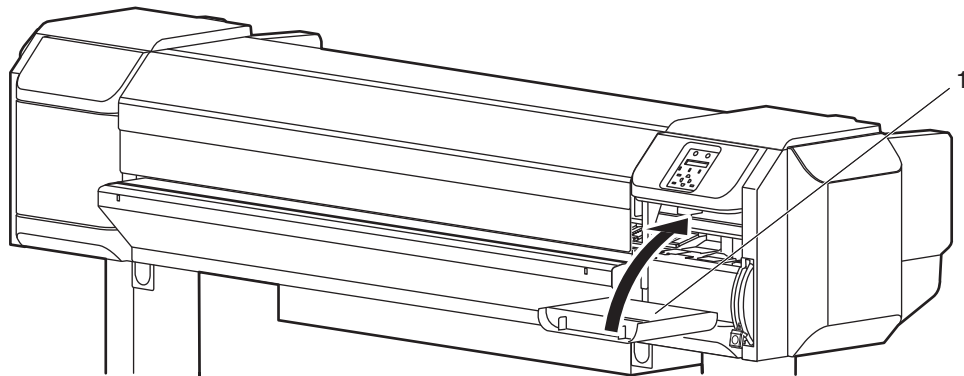

No.	Name
1	Maintenance cover

5. Press the [+] or [-] key to select “Installed Wiper? Yes”.

6. Press the [Enter] key.

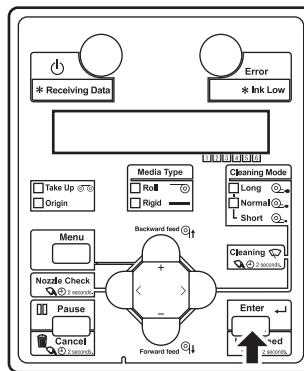

- “Start Ink Charge -> E” is displayed.

7. Press the [Enter] key.

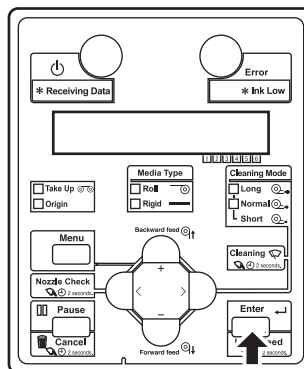

- “Ink Comb.: 4Color” is displayed.

8. Use the [+] or [-] key to select the number of ink colors you want to use.

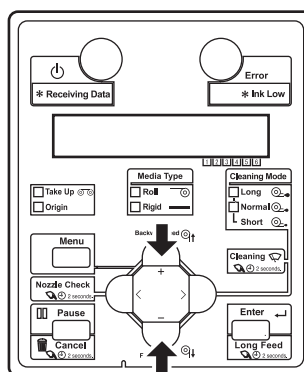

- “Ink Comb.: 4Color”:  
Cyan (C), Magenta (M), Yellow (Y), and Black (K)
- “Ink Comb.: 6Color”:  
Cyan (C), Magenta (M), Yellow (Y), Black (K), White (WH), and Varnish (VA)

9. Press the [Enter] key.

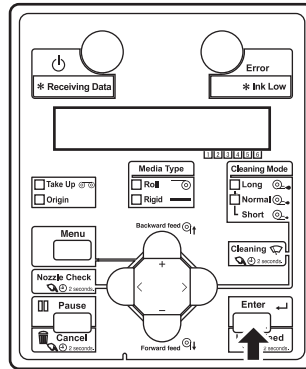

- “Empty WasteInk ->E” is displayed.

#### NOTE

If this message is displayed during operation, check waste fluid tank and remove any waste fluid. If there is waste fluid inside the tank, the cleaning liquid is wasted.

10. Press the [Enter] key.

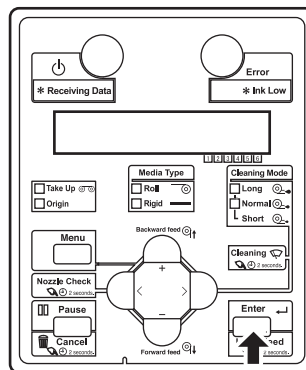

- “Insert CleaningCart.” is displayed.

11. Prepare the cleaning cartridges.

- Number of the cleaning cartridges required: 6

12. Insert cleaning cartridges into all Ink cartridge slots.

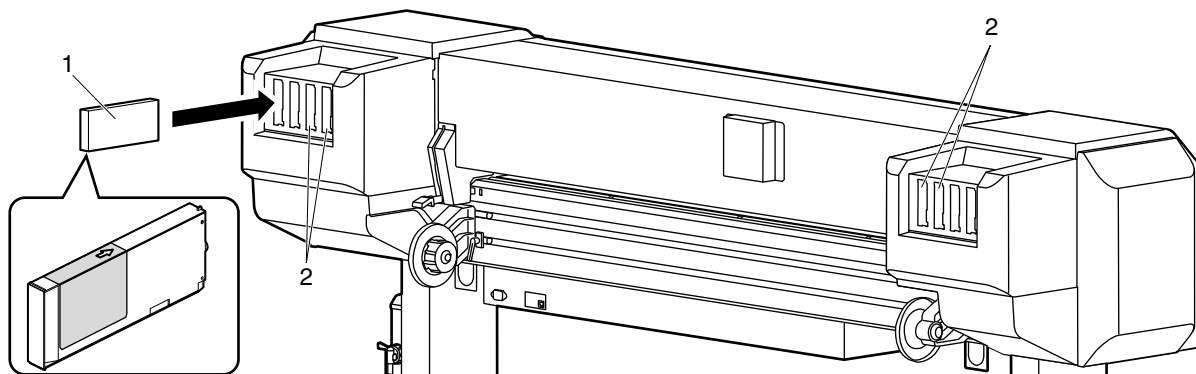

No.	Name
1	Cleaning cartridge
2	Ink cartridge slots

- Keep the arrow of Cleaning cartridge facing up and insert it into the printer.
- Insert Cleaning cartridges all the way in Ink cartridge slot.
- When all Cleaning cartridges are installed, “Busy-Washing” is displayed on Operation panel, and the printer starts charging the cleaning fluid.
- When Cleaning fluid has been charged, “Remove Cartridges” is displayed.

13. Remove all Cleaning cartridges.

- “Busy-Washing” is displayed and the printer starts Head cleaning.
- After Head cleaning is complete, “Empty WasteInk ->E” is displayed.
- Check Waste fluid tank, and dispose the waste fluid in it.

 [6.6 Disposal the waste fluids](#)

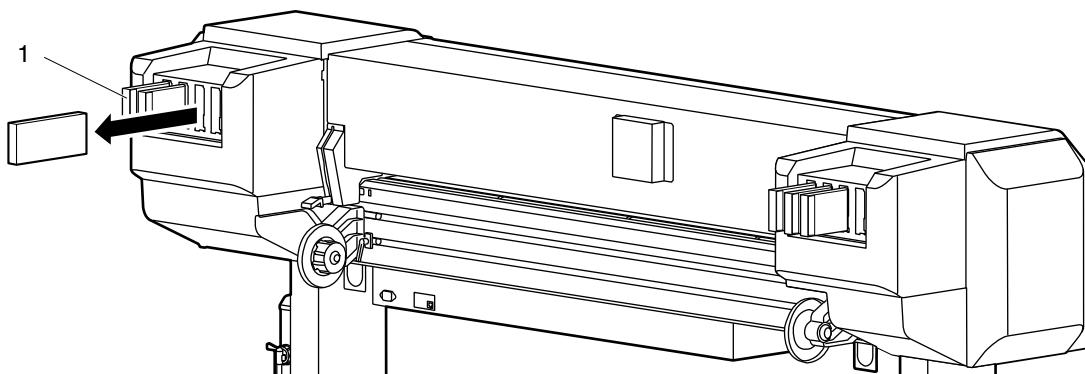

No.	Name
1	Cleaning cartridge

14. Press the [Enter] key.

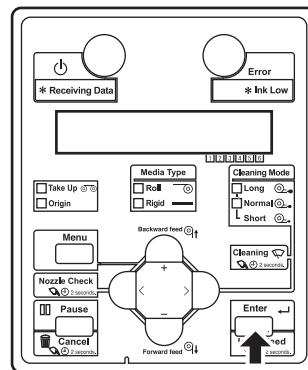

15. Prepare ink cartridges.

- The number of ink cartridges or Cleaning cartridges to be used differs depending on the number of colors selected in step 3.

(1) When using 4-color set

- Cyan (C): 2
- Magenta (M): 2
- Yellow (Y): 1
- Black (K): 1

(2) When using 6-color set

- Cyan (C): 1
- Magenta (M): 1
- Yellow (Y): 1
- Black (K): 1
- Varnish (VA): 1
- White (WH): 1

16. Shake ink cartridge.

- Turn the ink plug upward and wait for 3 seconds.
- Next, turn the ink plug downward and wait for 3 seconds.
- Repeat that 10 times.

**CAUTION**

- **Shake the ink cartridge before use.**
- **Shake the ink cartridges periodically.**  
Otherwise, the ink inside the cartridges settles or coagulates and may cause poor print quality or a malfunction.

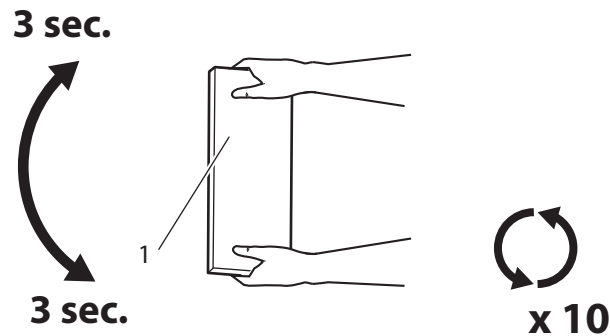

No.	Name
1	Ink cartridge

17. Install ink cartridges into Ink cartridge slots.

**NOTE**

Note that the ink colors and corresponding ink cartridge slots differ depending on the number of ink colors selected in step 3.

(1) When using 4-color set

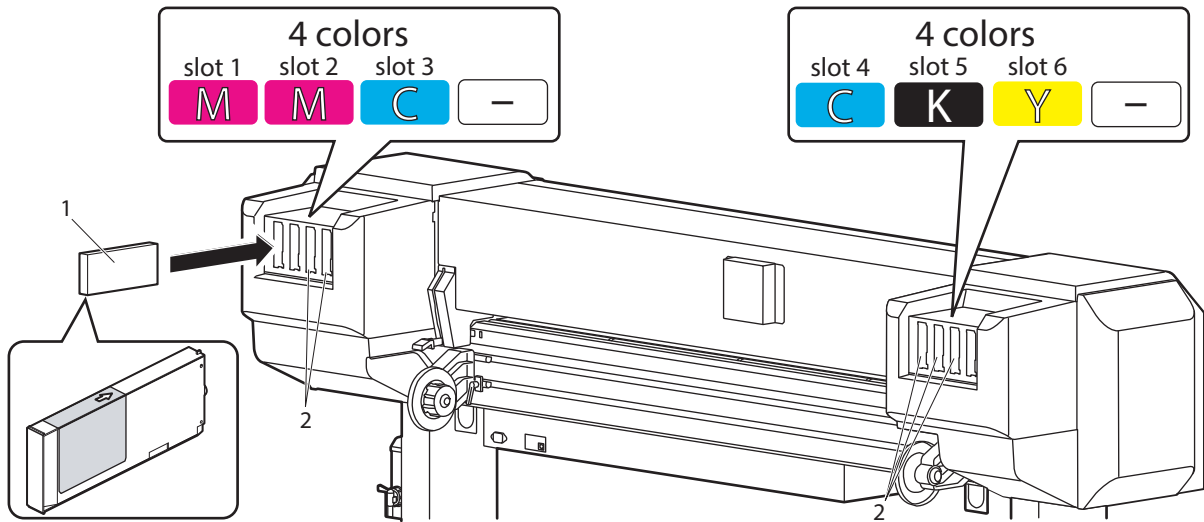

No.	Name
1	Ink cartridge
2	Ink cartridge slots

(2) When using 6-color set

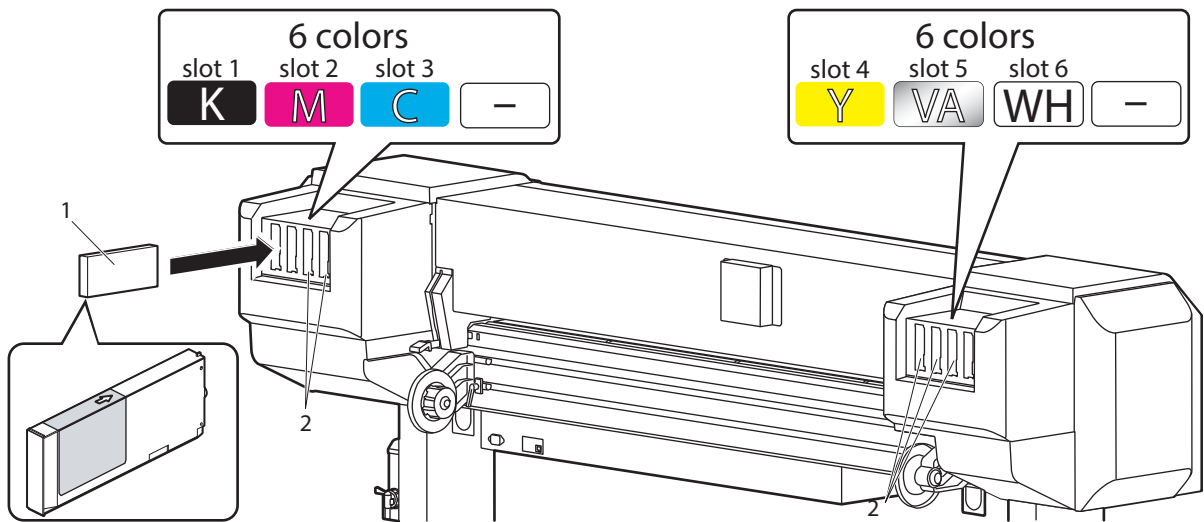

No.	Name
1	Ink cartridge
2	Ink cartridge slots

- You can check the ink color labels for ink colors and its cartridge slots.
- Keep the arrow of ink cartridge facing up and insert it into the printer.
- Insert ink cartridges all the way in Ink cartridge slot.
- When a ink cartridges are installed, “Ink Refill \*\*%” is displayed and ink charging starts.
- Initial ink charging takes about 10 minutes.
- Ink charging operation and pause operation are repeated during the initial ink charging.
- When “100%” is displayed, the initial ink charging is complete.
- After the initial ink charging is complete, “Media End” is displayed.

 **CAUTION**

- **Comply strictly with the following during ink charging.  
If charging is interrupted, ink will be lost when charging is resumed.**
  - **Do not turn OFF the printer.**
  - **Do not unplug the power cord set of the printer.**
  - **Do not open Front cover.**
  - **Do not open Maintenance cover.**
  - **Do not raise Front media loading lever (i.e., Do not lower Rear media loading lever).**
  - **Do not use ink cartridges that have little ink remaining.**

**NOTE**

If the printer perform the nozzle check printing immediately after initial charging is complete, the following results may occur.

- Printed lines become blurred.
- The data is partially not printed.

In such cases, follow “[5.5 Cleaning menu](#)” and perform “Little Charge”. Then, check the printing result.

If there is no improvement in the print result even after performing “Little Charge”, leave the printer unused for an hour or more. Then, perform “Little Charge” again and check the print result.

If there is still no improvement, contact your local MUTOH dealer.



## 3.5 Setting media

### 3.5.1 Installing Media-feed table

When using rigid media on this printer, use Media-feed table (optional).

Follow the procedure below to install Media-feed table.

The following items are required for installing Media-feed table:

- Spanner: Accessories for Media-feed table
- Level: provided with the printer

#### NOTE

See the printer's installation manual for how to assemble Media-feed table.

#### 3.5.1.1 Rear side

1. Loosen the fixing levers on the right and left side of the rear. Set the distance between the roll media holders wider than the roll media width.

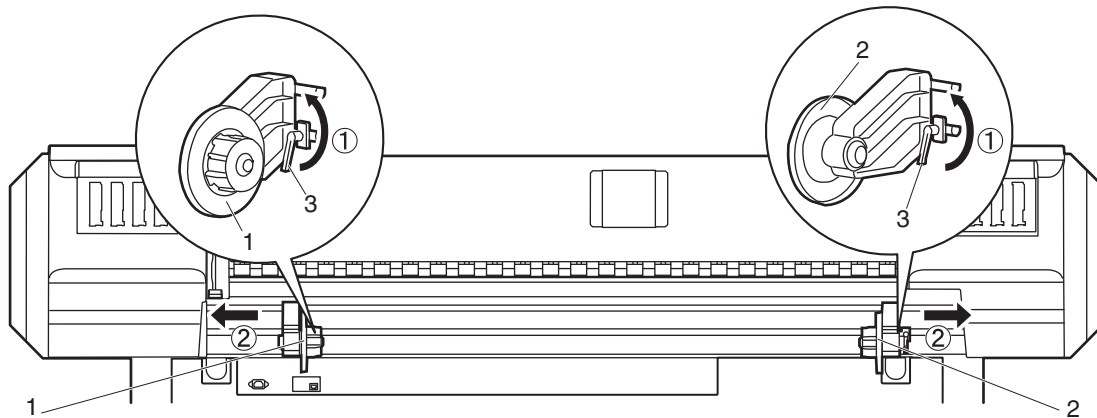

No.	Name
1	Roll media holder (left)
2	Roll media holder (right)
3	Fixing lever

2. Loosen retaining screws of Media-feed table, and slowly level the table.

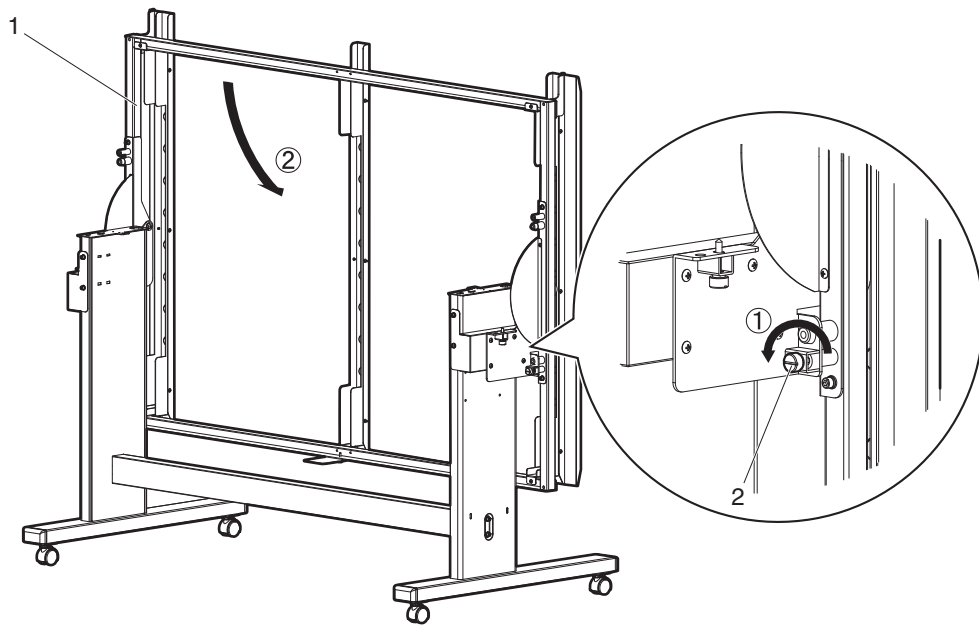

No.	Name
1	Media-feed table
2	Leveling screw

3. Tighten the leveling screws of Media-feed table (2 places, both sides), and fix the table.

**NOTE**

When fixing the leveling screws, hold the frame while pressuring the rubber foot, and then turn the screw until it doesn't turn any further.

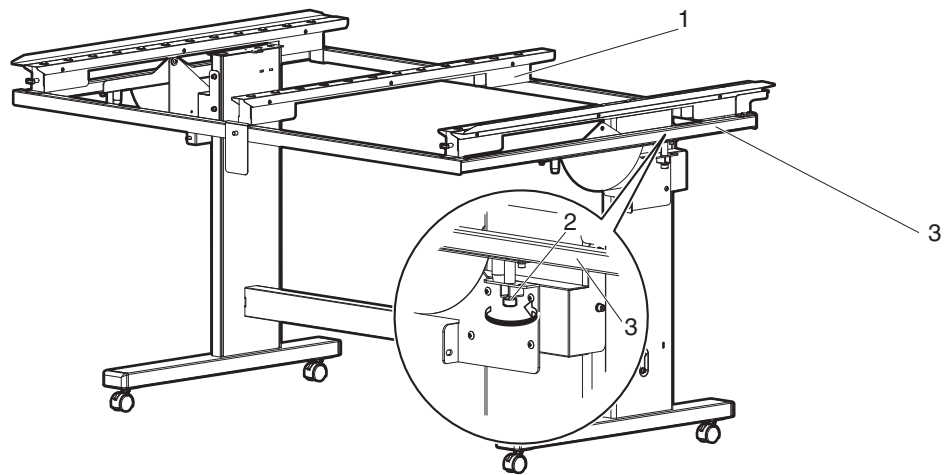

No.	Name
1	Media-feed table
2	Leveling screw
3	Frame

4. Insert the positioning guide of Media-feed table into the square hole of Paper guide R.
- If the height of the positioning guide does not match the square hole, turn the screw of Media-feed table's caster, and adjust the height. (See step 5.)

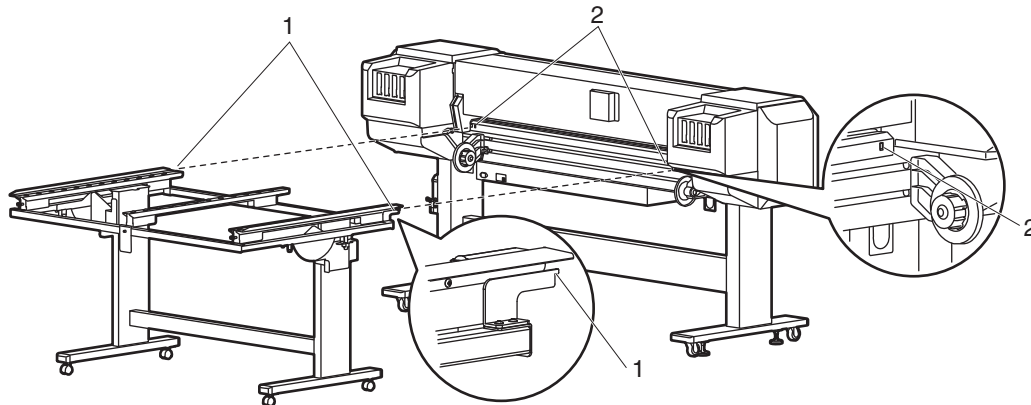

No.	Name
1	Positioning guide
2	Square hole

5. Turn the screws on the caster of Media-feed table (2 places, ones closer to the printer) with a spanner. Adjust so that there is a 6 mm gap between the top side of the square hole of Paper guide R and the top side of the positioning guide.

**NOTE**

- Caster of Media-feed table has 2 types of screws. Turn the bottom screw.
- Turn the screw clockwise to raise Media-feed table.

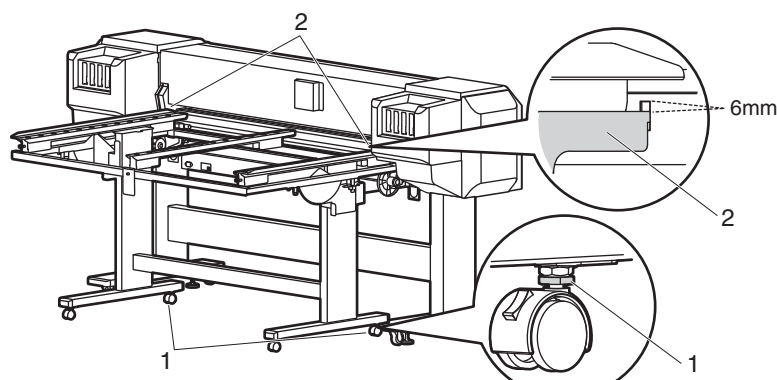

No.	Name
1	Screws on the casters
2	Positioning guide

- Place the level at the edge of printer's platen, and check the position of the air bubble.

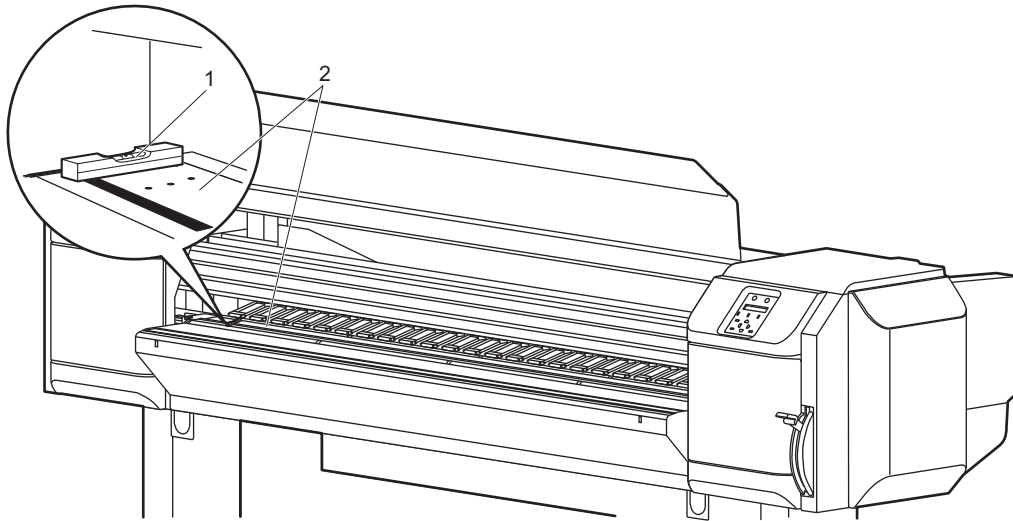

No.	Name
1	Level
2	Platen

- Place the level on the frame of Media-feed table.  
Place the level on the same side as when you placed it on the printer.

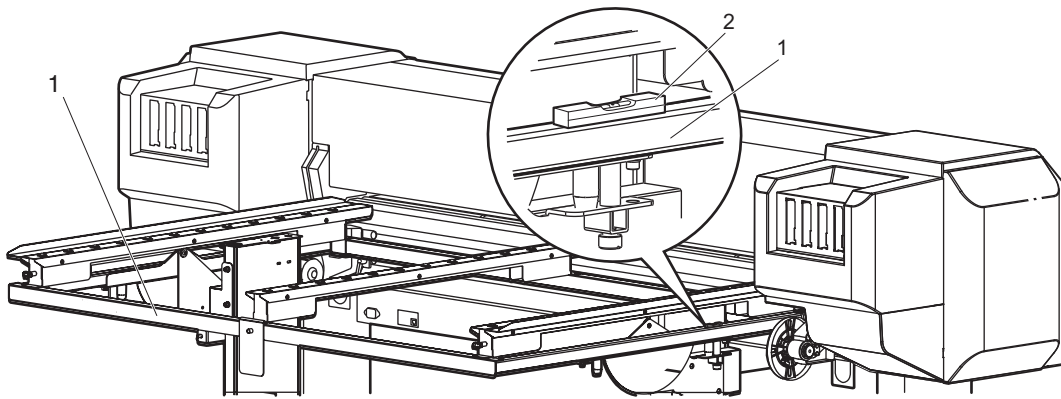

No.	Name
1	Level
2	Frame of Media-feed table

8. Turn the screw of Media-feed table's caster (the one further from the printer) with a spanner, and adjust the slant.
- Make sure that the position of the level's air bubble is at the same position as when you place it on the printer.

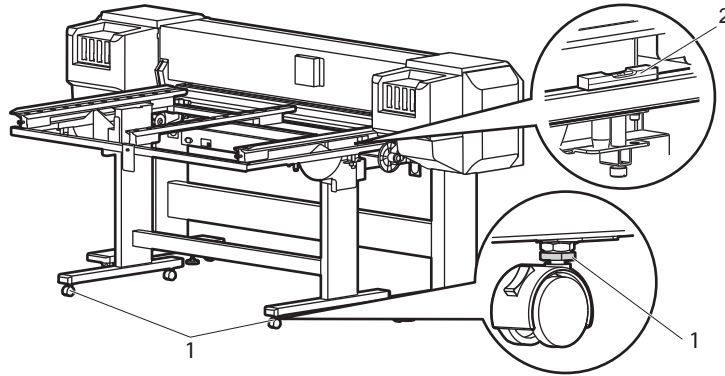

No.	Name
1	Screws on Casters
2	Level

9. Adjust the slant on the other side in the same way.

**CAUTION**

- If Media-feed table's slanted, media may touch Print head, and Print head may break.

### 3.5.1.2 Front side

1. Loosen retaining screws of Media-feed table, and slowly level the table.

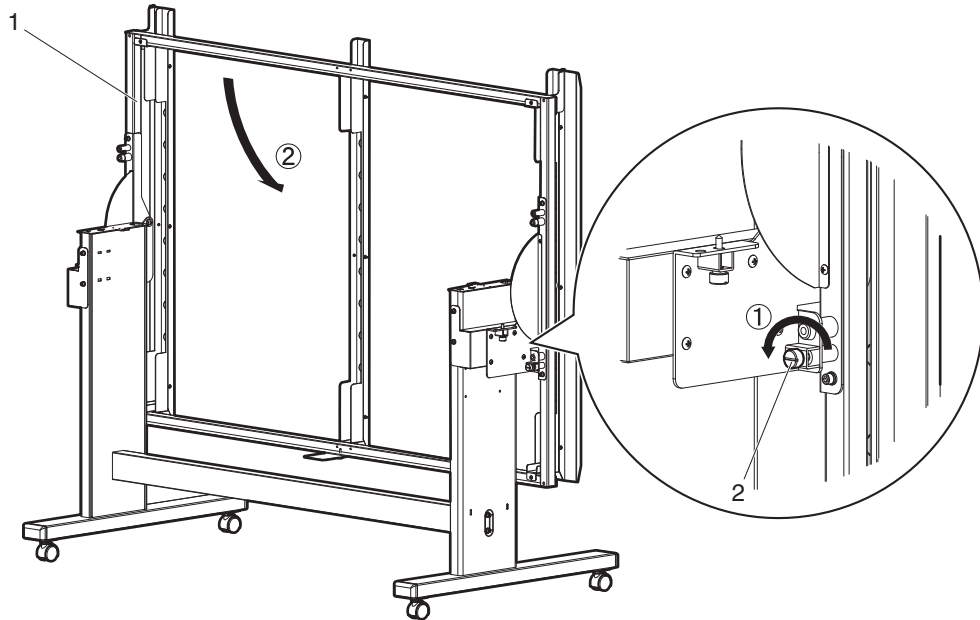

No.	Name
1	Media-feed table
2	Leveling screw

- Tighten the leveling screws of Media-feed table (2 places, both sides), and fix the table.

**NOTE**

When fixing the leveling screws, hold the frame while pressuring the rubber foot, and then turn the screw until it doesn't turn any further.

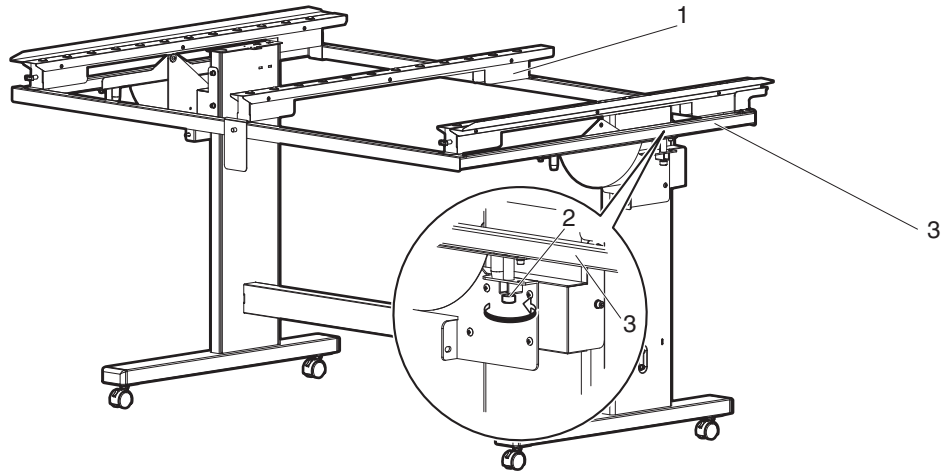

No.	Name
1	Media-feed table
2	Leveling screw
3	Frame



3. Insert the positioning guide of Media-feed table into the square hole of Paper guide F.
  - If the height of the positioning guide does not match the square hole, turn the screw of Media-feed table's caster, and adjust the height. (See step 4.)

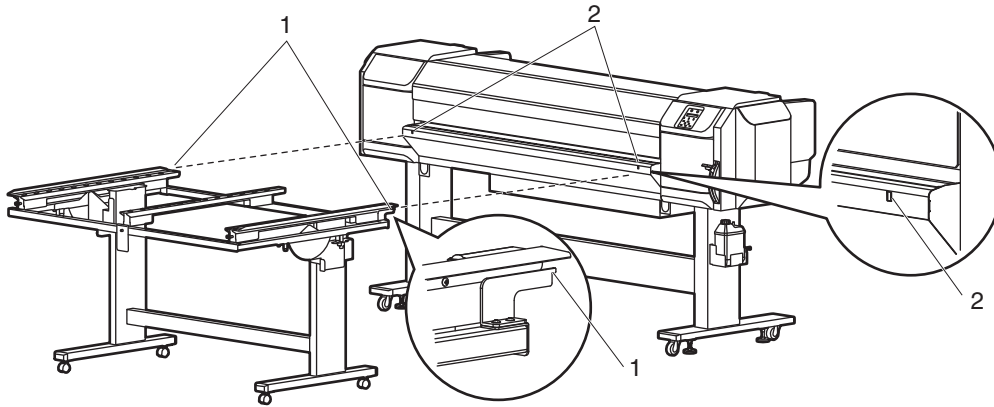

No.	Name
1	Positioning guide
2	Square hole

4. Turn the screws on the caster of Media-feed table (2 places, ones closer to the printer) with a spanner. Adjust so that there is a 6 mm gap between the top side of the square hole of Paper guide F and the top side of the positioning guide.

**NOTE**

- Caster of Media-feed table has 2 types of screws. Turn the bottom screw.
- Turn the screw clockwise to raise Media-feed table.

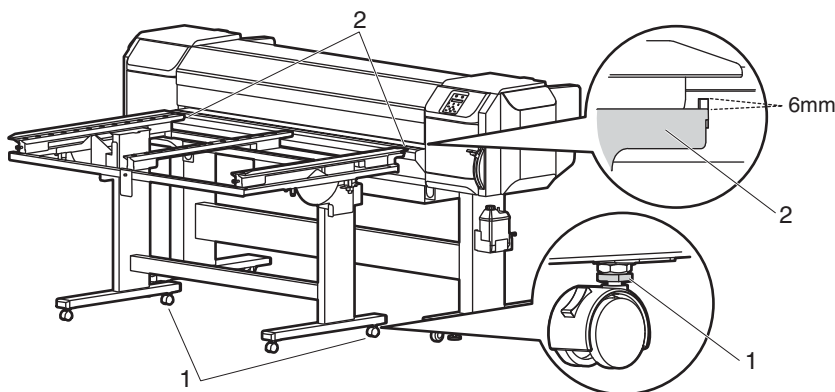

No.	Name
1	Screws on Caster
2	Positioning guide

5. Place the level at the edge of printer's platen, and check the position of the air bubble.

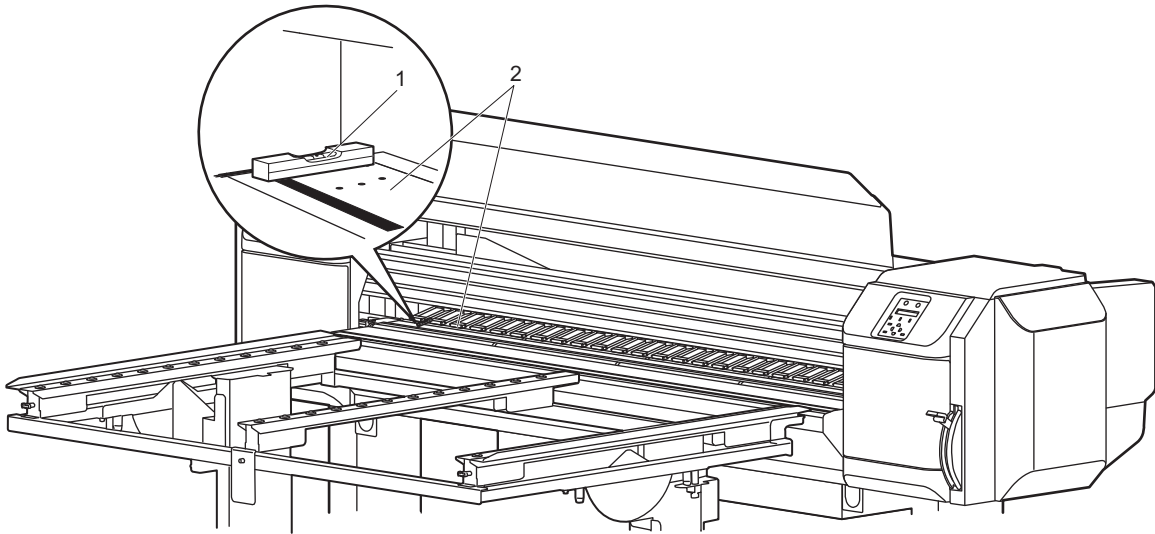

No.	Name
1	Level
2	Platen

6. Place the level on the frame of Media-feed table.  
Place the level on the same side as when you placed it on the printer.

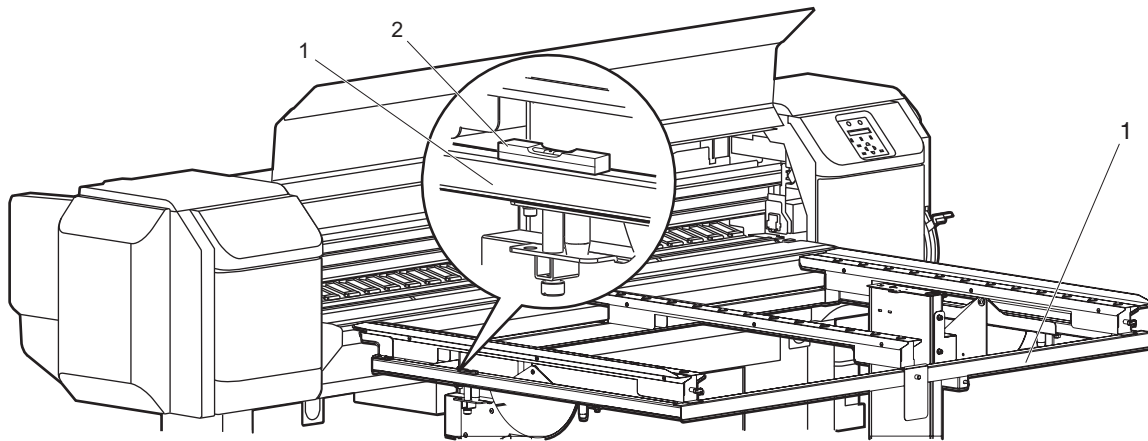

No.	Name
1	Frame of Media-feed table
2	Level

7. Turn the screw of Media-feed table's caster (the one further from the printer) with a spanner, and adjust the slant.  
Make sure that the position of the level's air bubble is at the same position as when you place it on the printer.

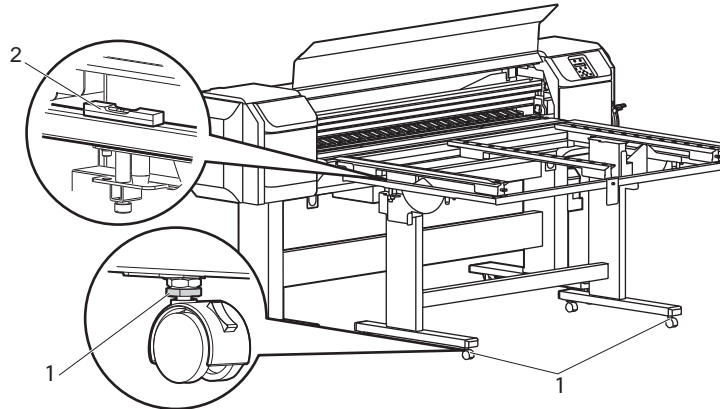

No.	Name
1	Screws on Caster
2	Level

8. Adjust the slant on the other side in the same way.

### 3.5.2 Loading rigid media

**NOTE**

You can load the following rigid media on this printer:

- Maximum width: 1,625 mm
  - Minimum width: 182 mm
  - Maximum depth: 1,200 mm
  - Minimum depth: 200 mm
  - Thickness: 15 mm or less (including media warpage and unevenness)
  - Weight: 15 kg or less
  - Media warpage: Less than 1 mm. (when the media thickness is uneven, make sure that the total of the warpage and unevenness is less than 1 mm. Also, do not print with the warpage facing up.)
- 

See the following for loading the rigid media (only when adjusting Media-feed table).

- Spanner: provided with Media-feed table

Follow the procedure below to load the rigid media.

1. Turn the printer ON.
2. In Panel setup menu, check if the media type for the User type you're going to use is appropriately set.
  - ☞ [4.3.2 Menu setup procedure](#)
  - ☞ [5.2.2.10 Rigid/Roll menu](#)

**NOTE**

If the type of the media you have loaded differs from that of the user type you have set, the media may not be detected properly.

---

## 3. Raise Front media loading lever (lower Rear media loading lever).

- Media-feed table is excluded from the illustration for simplicity.

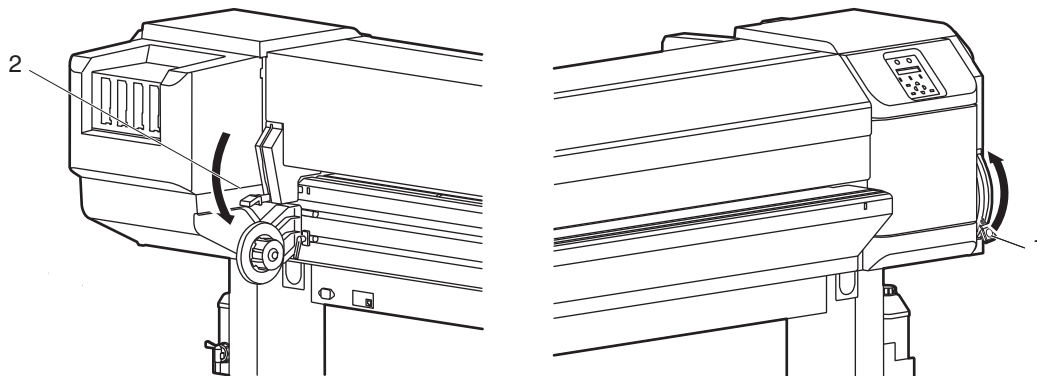

No.	Name
1	Front media loading lever
2	Rear media loading lever

## 4. Open the front cover.

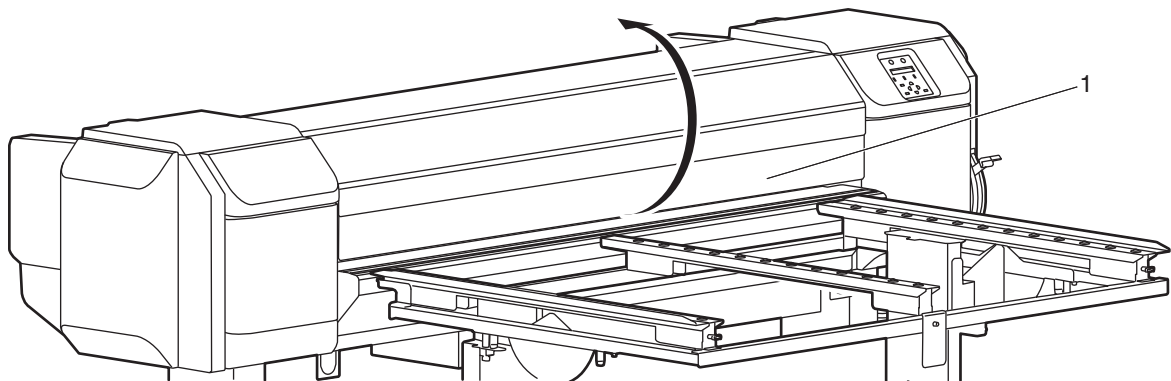

No.	Name
1	Front cover

5. Loosen the rail retaining screw on Media-feed table (rear side), and widen the rails to the sides so that you can place the rigid media.  
Make sure that the rigid media is set on the center of the printer.

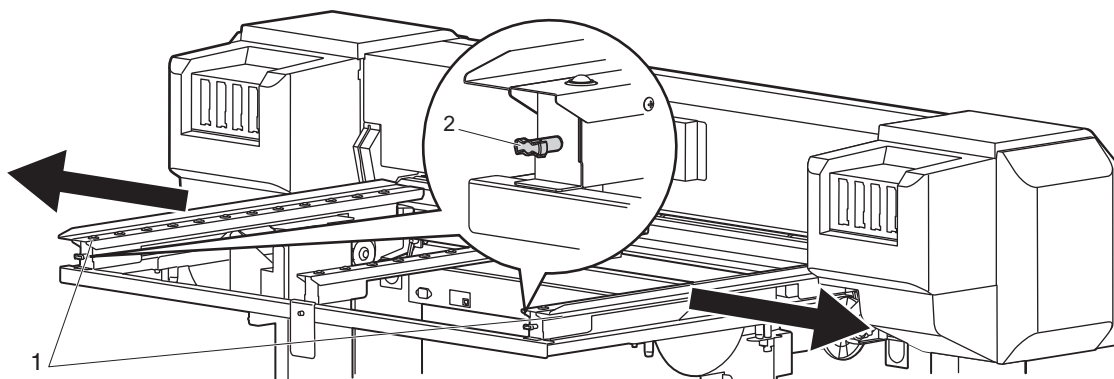

No.	Name
1	Rail
2	Rail retaining screws

6. Place the rigid media on the rails and tighten the rail retaining screw at where there is a 5 mm gap between the stoppers on both sides and the media.
- Make sure that the rigid media is placed parallel to the media feeding direction.
  - Make sure that the rigid media is placed on the ball part on the rails.
  - Adjust and fix the rails so that they are parallel to the rigid media.

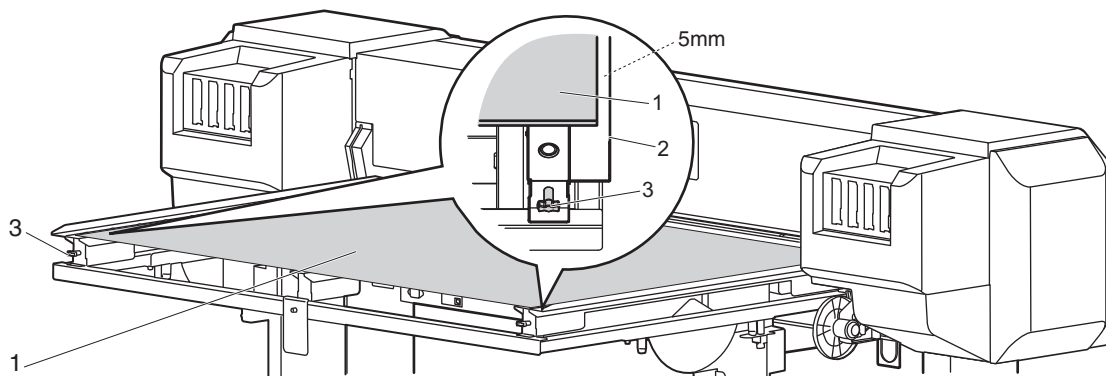

No.	Name
1	Rigid media
2	Stopper
3	Rail retaining screw

- Place the rigid media on Media-feed table (front side) in the same way, and fix the rails at where there is a 5 mm gap between the stoppers on both sides and the media.

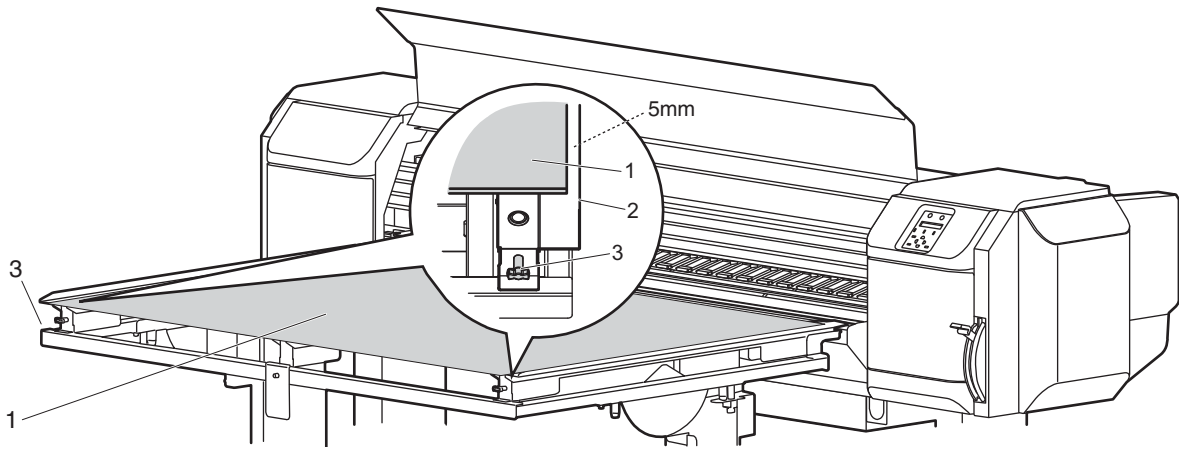

No.	Name
1	Rigid media
2	Stopper
3	Rail retaining screw

**NOTE**

If the rigid media slides down forward, use Media stopper.

☞ [2.2 Names of parts and functions](#)

- From the rear side of the printer, insert the rigid media into Media feed slot.

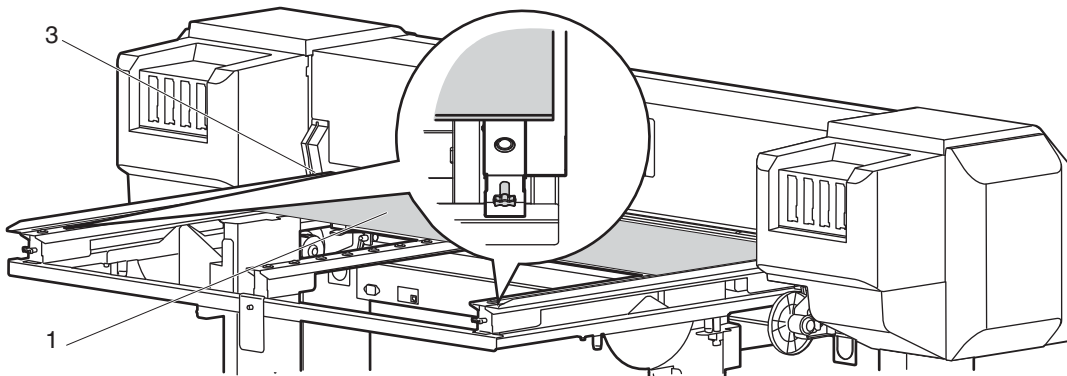

No.	Name
1	Rigid media
2	Media feed slot

- If the right edge of the roll media goes further right from the loading mark when seen from the front, adjust the position of Media-feed table's rails.

**TIP**

Loading mark is not used for deciding where the right edge of the media should be placed. There should be no problem if the media is placed away from the line, as long as it does not go beyond the line.

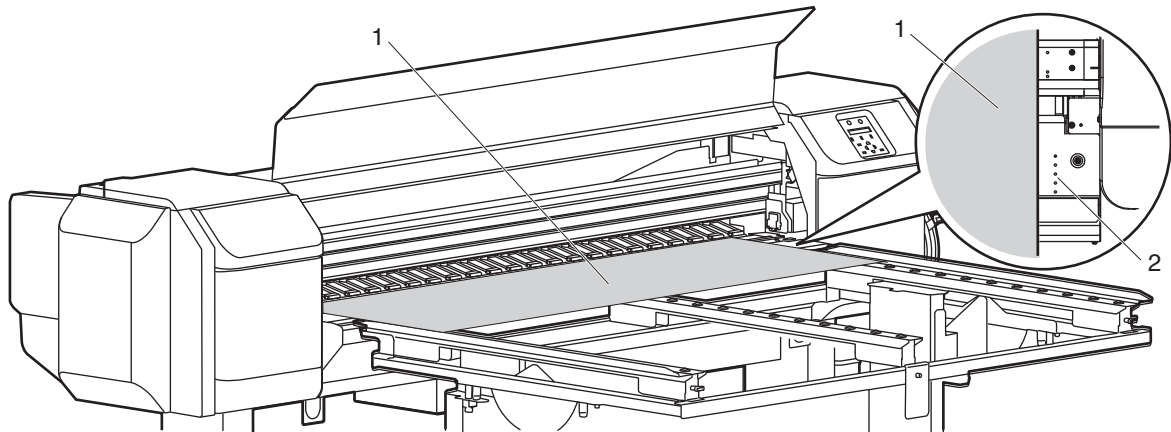

No.	Name
1	Rigid media
2	Media loading mark

- If the both edges of the media do not cover more than half of Pressurizing rollers, adjust the position of Media-feed table's rails.

When loading the rigid media so that it does not cover more than half of Pressuring rollers, make sure that the both edges of the media does not cover Pressurizing rollers.

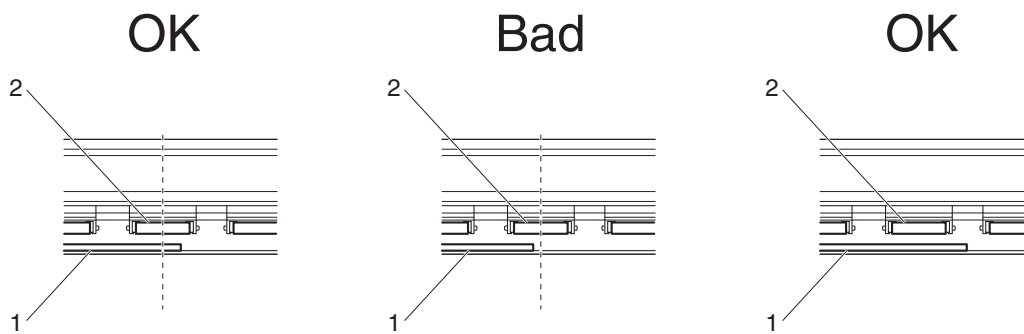

No.	Name
1	Rigid media
2	Pressurizing roller



11. Lower Front media loading lever. (Raise Rear media loading lever)

- Media-feed table is excluded from the illustration for simplicity.

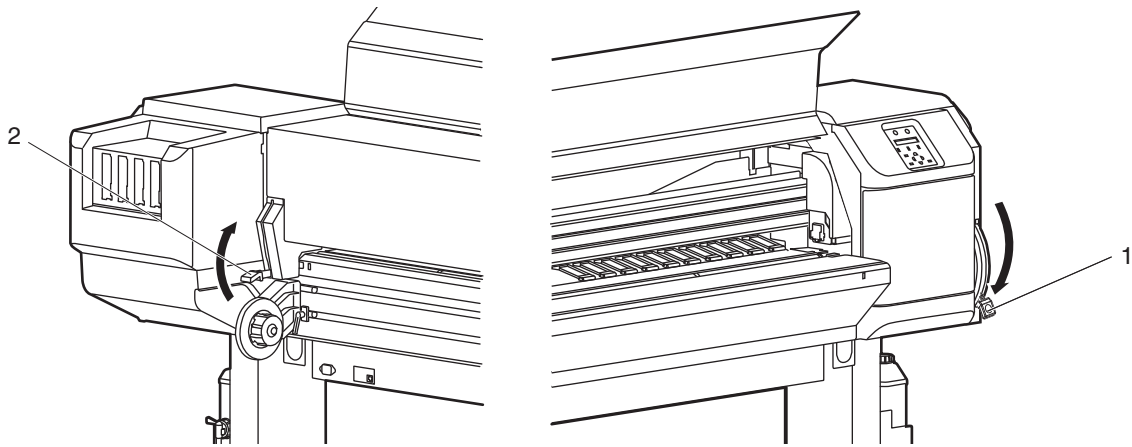

No.	Name
1	Front media loading lever
2	Rear media loading lever

**NOTE**

Push Front media loading lever down and lower it firmly. For Rear media loading lever, push it up firmly.  
 If the lever is not firmly lowered or raised, the media may not be detected.

12. Close Front cover.

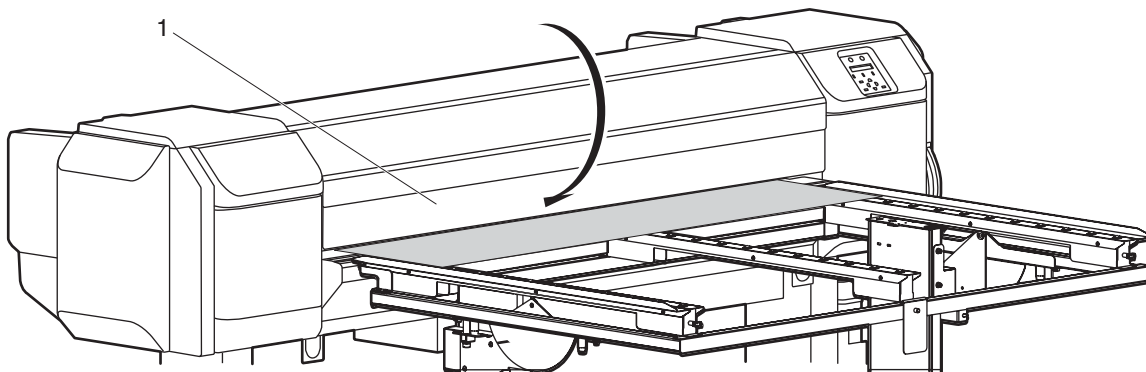

No.	Name
1	Front cover

13. Press down the [-] key for a while, and check that the rigid media can be fed no problem.

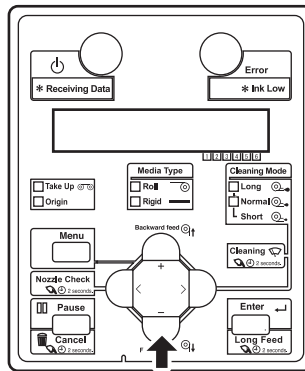

- Perform checking on the whole surface of the rigid media.
14. When feeding does not go smoothly, turn the screws of the front and back casters of Media-feed table (4 places each) with a spanner and raise the height slowly to adjust the position for smoother feeding.

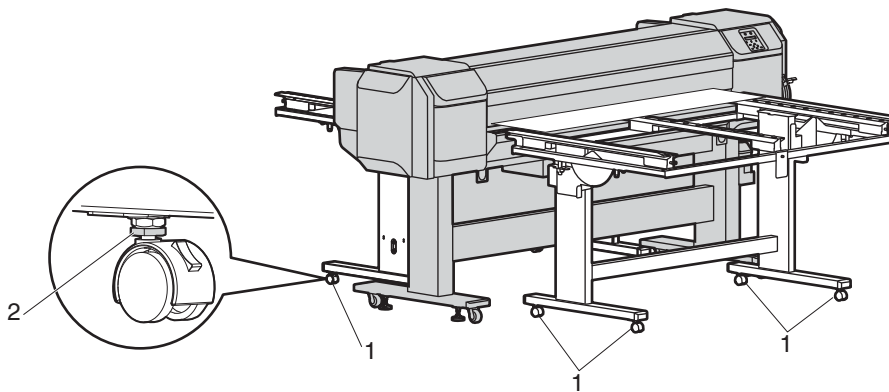

No.	Name
1	Caster
2	Screw

15. Raise Front media loading lever (lower Rear media loading lever), and put the rigid media back to the original position.

- Media-feed table is excluded from the illustration for simplicity.

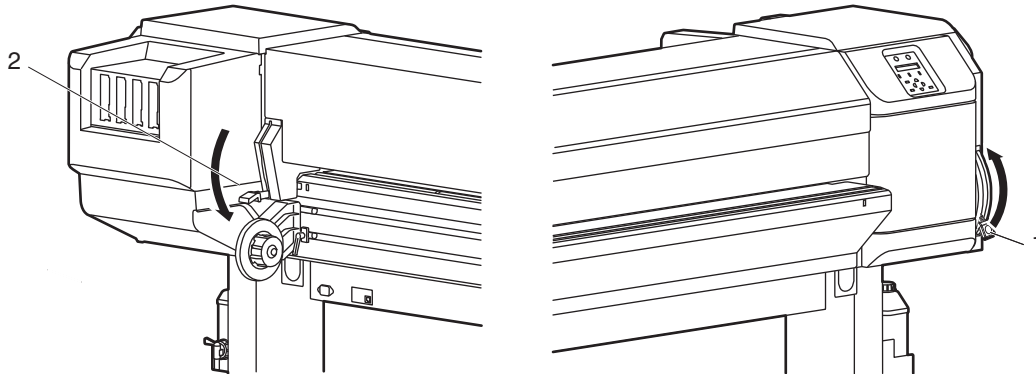

No.	Name
1	Front media loading lever
2	Rear media loading lever
3	Rigid media

16. Lower Front media loading lever (raise Rear media loading lever).

17. Use a spanner and tighten the hexagon nuts of the caster's height adjuster (4 places) toward the Media-feed table side.

- The height of the caster is fixed.

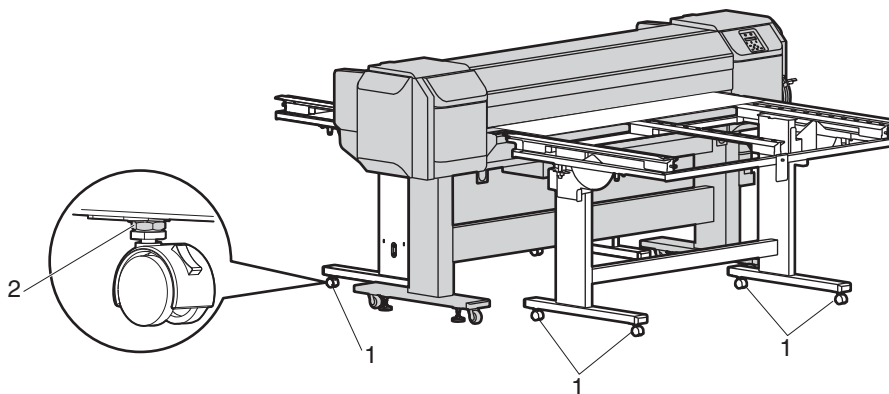

No.	Name
1	Caster height adjuster
2	Hexagon nut

**NOTE**

After fixing the caster height, even when Media-feed table is removed, you do not need to adjust Media-feed table's height in the following situation.

- Printer has not been moved
  - Media type has not been changed
- 

- The procedure for setting the rigid media is complete.
- Make setting for the media type.  
↳ [3.5.6 Setting media type](#)

### 3.5.3 Removing Media-feed table (optional)

This section explains how to remove Media-feed table.

When Media-feed table (optional) is installed on the printer, remove it before using the roll media.

Follow the procedure below to remove Media-feed table.

1. Remove Media-feed table on the front side of the printer.
  - a. Pull Media-feed table forward, and remove the positioning guide from the hole of Paper guide F.

#### NOTE

When removing Media-feed table, make sure that you do not damage the printer with the positioning guide.

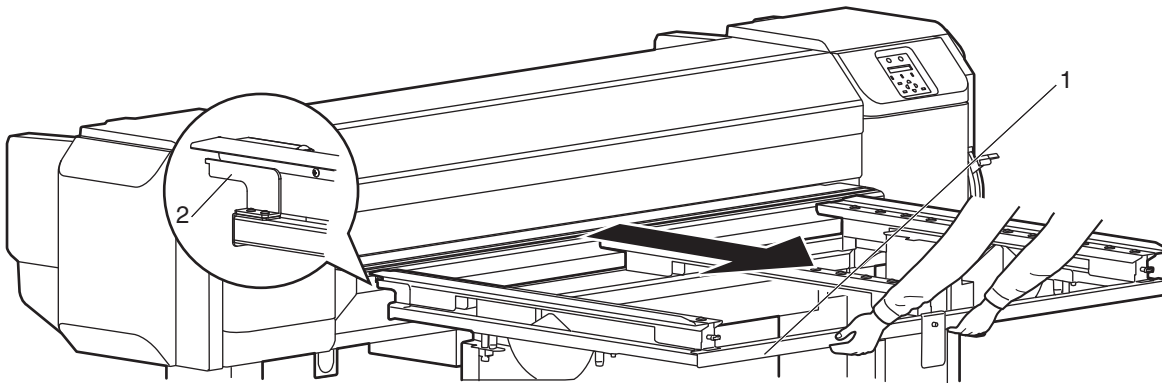

No.	Name
1	Media-feed table
2	Positioning guide

b. Loosen the leveling screws (2 places, both sides), and fold Media-feed table.

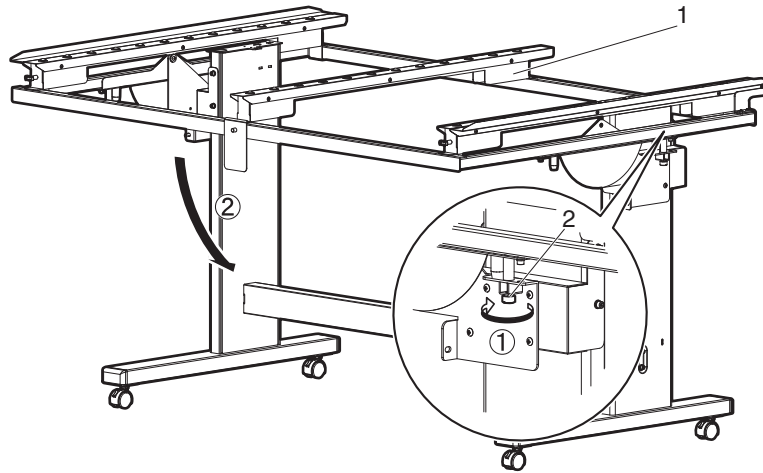

No.	Name
1	Media-feed table
2	Leveling screws

c. Tighten the vertical retaining screws and fix Media-feed table.

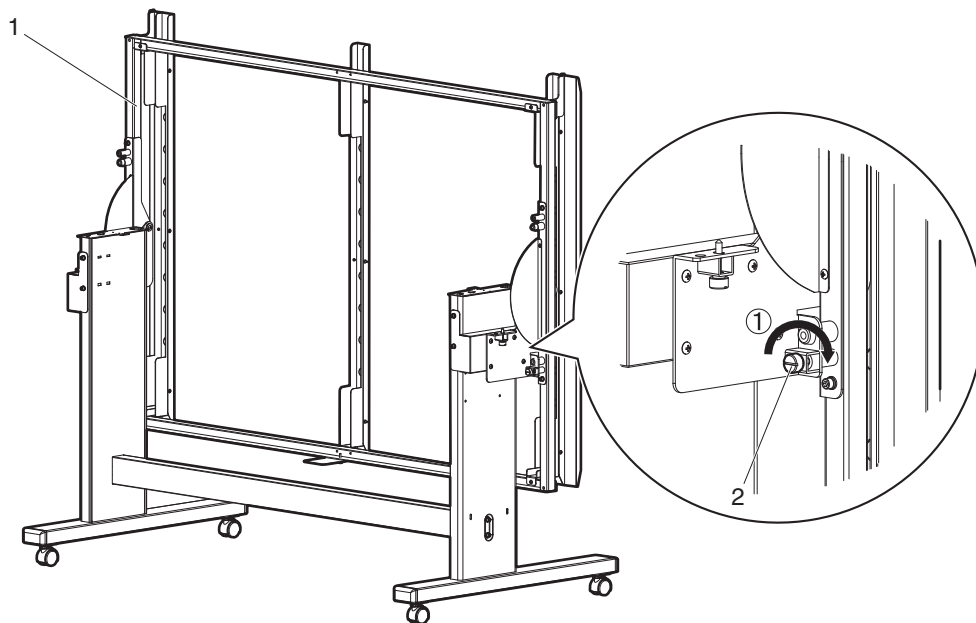

No.	Name
1	Media-feed table
2	Leveling screws

2. Remove Media-feed table on the rear side of the printer.
  - a. Pull Media-feed table forward, and remove the positioning guide from the hole of Paper guide R.

**NOTE**

When removing Media-feed table, make sure that you do not damage the printer with the positioning guide.

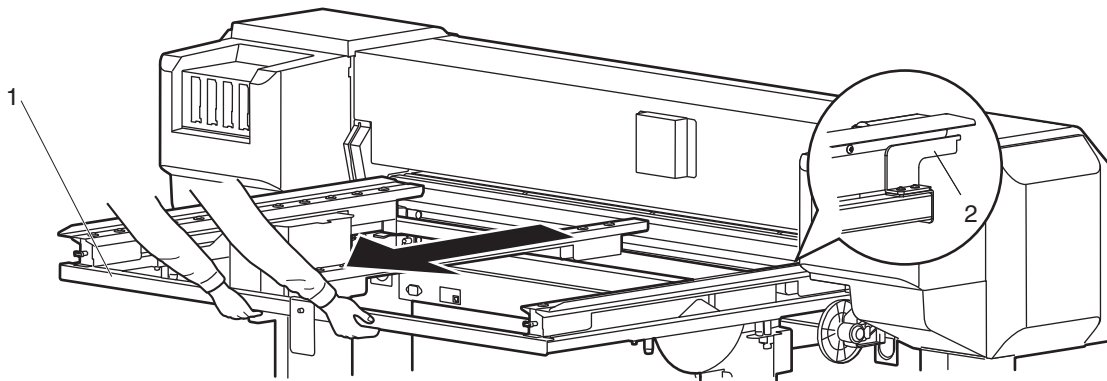

No.	Name
1	Media-feed table

- b. In the same way as the front side, fold Media-feed table.

- This completes removing Media-feed table.
- Load the roll media on the printer.  
 [3.5.4 Loading roll media](#)

### 3.5.4 Loading roll media

This section explains how to load roll media.  
Put the roll media in the center.

#### NOTE

The following roll media can be attached to the scroller supplied with this unit.

- Outer diameter: 150 mm or less
- Tube diameter: 2 or 3 inches
- Weight: 30 kg or less
- Length: 50 m or less
- Width: 1,625 mm or less

 [8.1.1 Printer specifications](#)

Follow the procedure below to load roll media.

1. Loosen the fixing levers on the right and left side of the rear. Set the distance between the roll media holders wider than the roll media width.

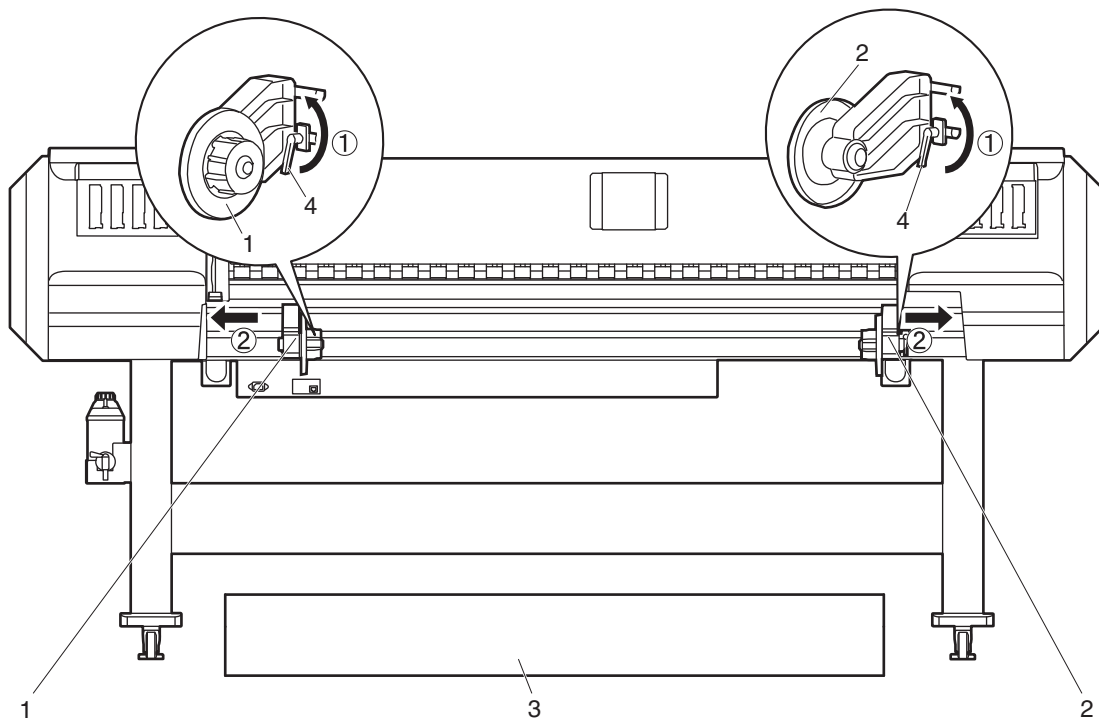

No.	Name
1	Roll media holder (Left)
2	Roll media holder (Right)
3	Roll media
4	Fixing lever



2. Tighten the fixing lever on the left of Roll media holder, and fix the Roll media holder (Left).

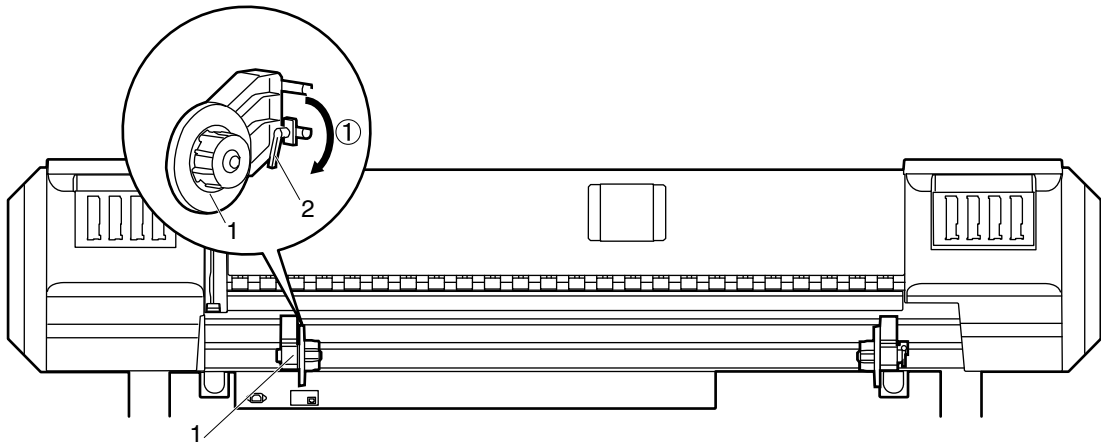

No.	Name
1	Roll media holder (Left)
2	Fixing lever

3. Set the roll media to the roll media holder (Left).

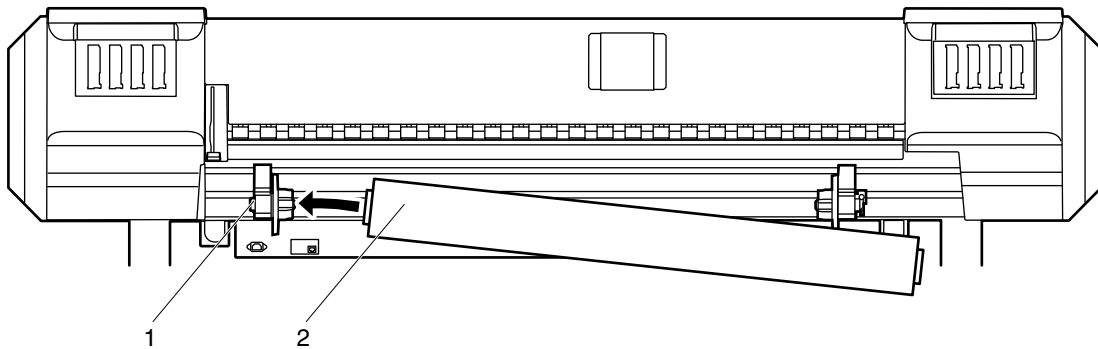

No.	Name
1	Roll media holder (Left)
2	Roll media

4. Set the roll media to the roll media holder (Right) and fixed the fixing lever.

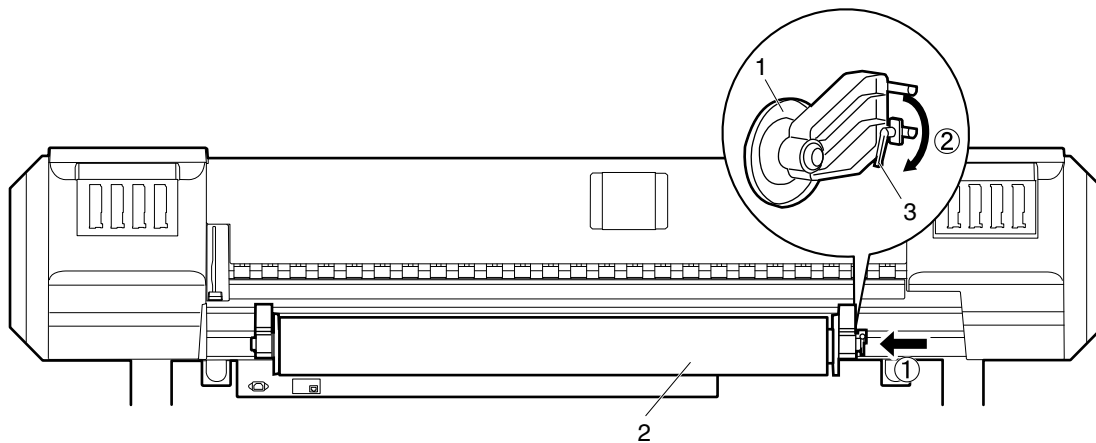

No.	Name
1	Roll media holder (Right)
2	Roll media
3	Fixing lever

5. Loosen the fixing levers of the right and left roll media holders, move the roll media to the center and tighten the levers.

**NOTE**

Fix the roll media holders by pressing the holders to the printer.

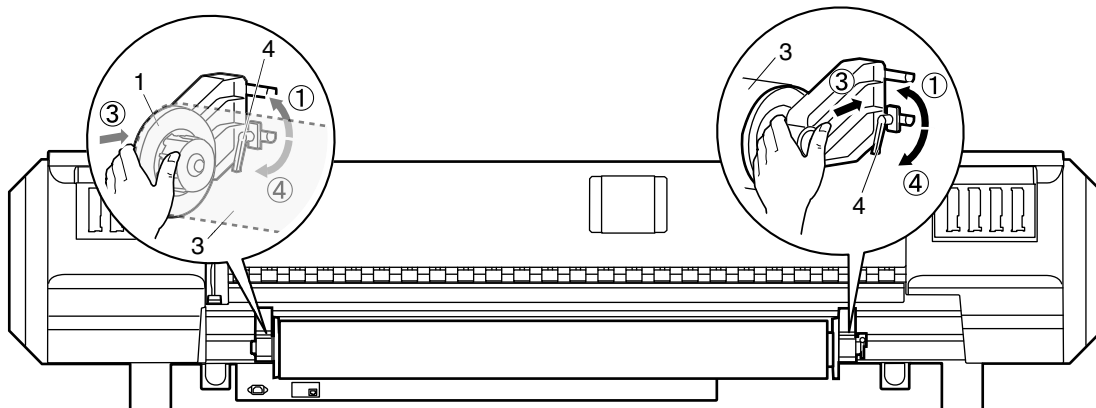

No.	Name
1	Roll media holder (Left)
2	Roll media holder (Right)
3	Roll media
4	Fixing lever

- The procedure for loading the roll media is complete.
- Set the roll media to the printer continuously as shown below.

 [3.5.5 Setting roll media](#)

### 3.5.5 Setting roll media

This section explains how to set roll media.

Follow the procedure below to set roll media.

1. Turn the unit ON.

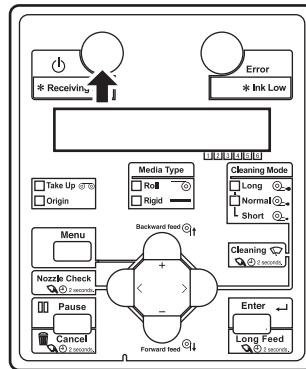

#### **CAUTION**

- Do not operate the media loading lever during initial operation and printing. The print head portion may touch the pressurizing roller portion, and cause a malfunction.

- The printer starts the initializing operation.
  - “Media End” is displayed.
2. In Panel setup menu, check if the media type for the User type you’re going to use is appropriately set.
    - ☞ [4.3.2 Menu setup procedure](#)
    - ☞ [5.2.2.10 Rigid/Roll menu](#)

#### **NOTE**

If the type of the media you have loaded differs from that of the user type you have set, the media may not be detected properly.

3. Raise Front media loading lever (lower Rear media loading lever).

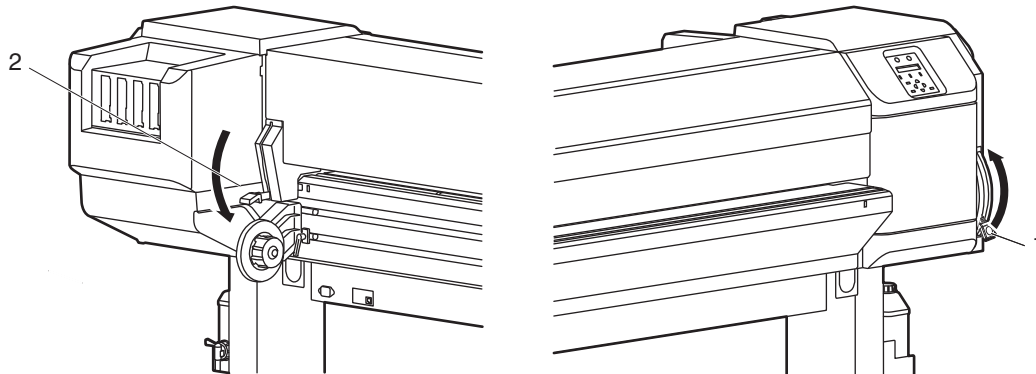

No.	Name
1	Front media loading lever
2	Rear media loading lever

- “Lever Up” is displayed.

4. Open the front cover.

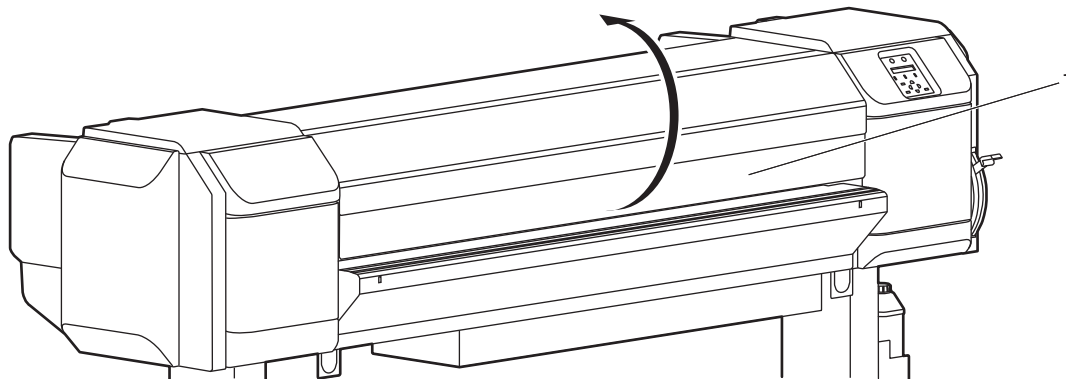

No.	Name
1	Front cover

- Set the roll media to the media feed slot.

**NOTE**

If the end of the roll media is not wound tightly, wind it tightly again, and then load it.

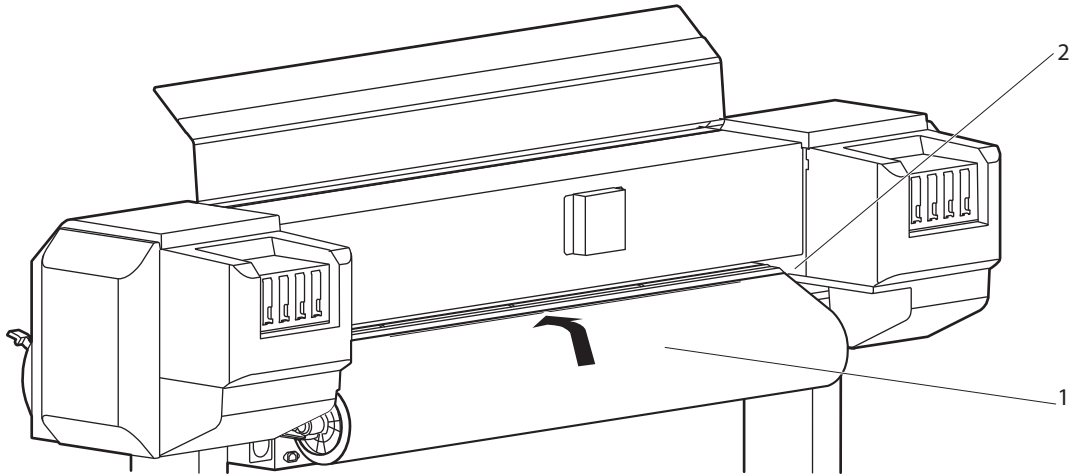

No.	Name
1	Roll media
2	Media feed slot

- Pull the roll media out about 1 m from the front media feed slot which is located inside of the front cover.

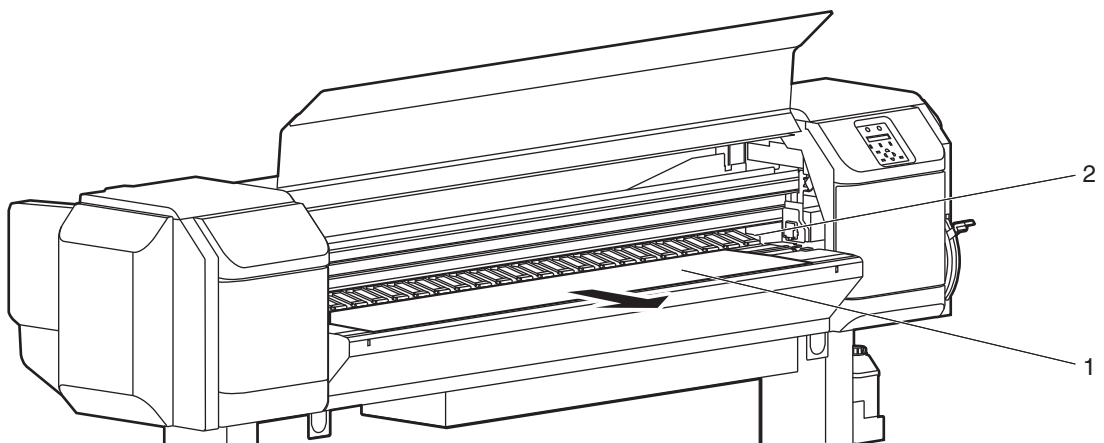

No.	Name
1	Roll media
2	Media feed slot

- Rewind the roll media a little by rolling the flange on the roll media holder while holding the edge of the media, and eliminate any slack or slant.

**NOTE**

- If you rewind the roll media too much, the roll media may come off from Media feed slot and may fall on the rear side of the printer.
- If the right edge of the roll media is placed further right of the loading mark, media detection may fail, possibly affecting print quality.

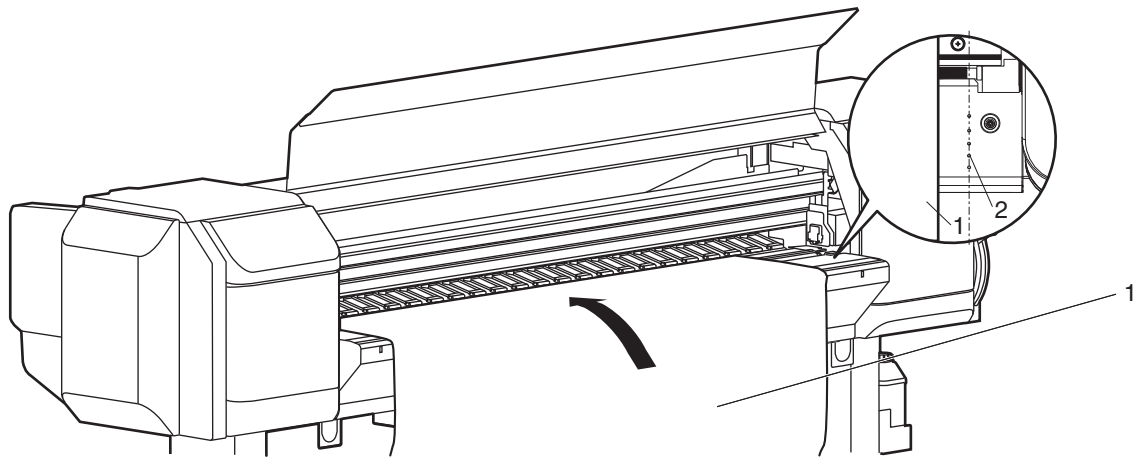

No.	Name
1	Roll media
2	Media loading mark

**NOTE**

When setting the roll media, set both sides of the media at least 5 mm away from the edge of the pressurizing roller.  
Slippage or creases may occur during printing.

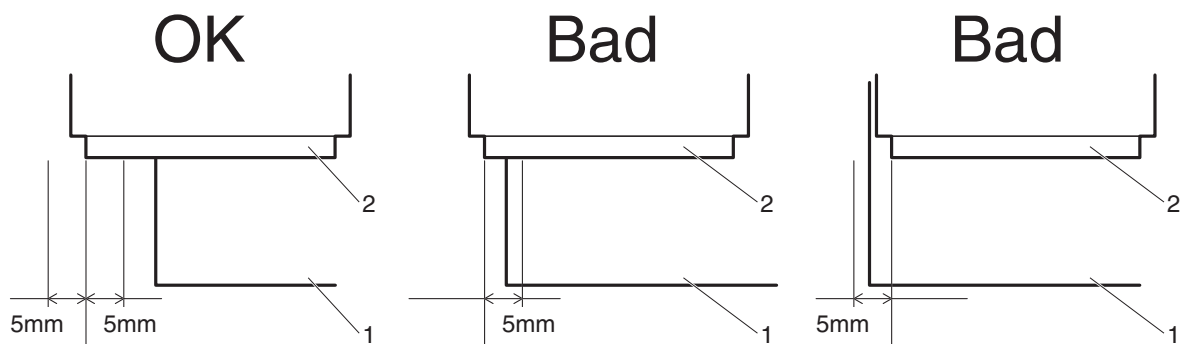

No.	Name
1	Roll media
2	Pressurizing rollers

8. If the edge of the roll media is set less than 5 mm from the edge of the pressurizing roller, follow the procedure below to adjust the position of the roll media.
  - a. Loosen Fixing levers (①) of the right and left Roll media holders, and move the roll media to left or right(②).
  - b. While pushing Roll media holders toward the product (③), tighten Fixing levers of the right and left Roll media holders (④).

**NOTE**

If you have moved the roll media to the sides, repeat the steps 5 to 7.

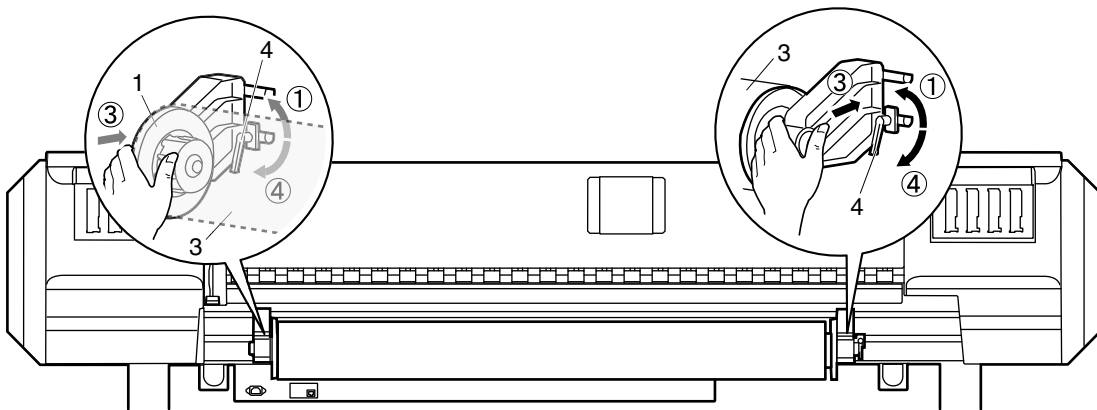

No.	Name
1	Roll media holder (Left)
2	Roll media holder (Right)
3	Roll media
4	Fixing lever

9. Lower Front media loading lever (raise Rear media loading lever).

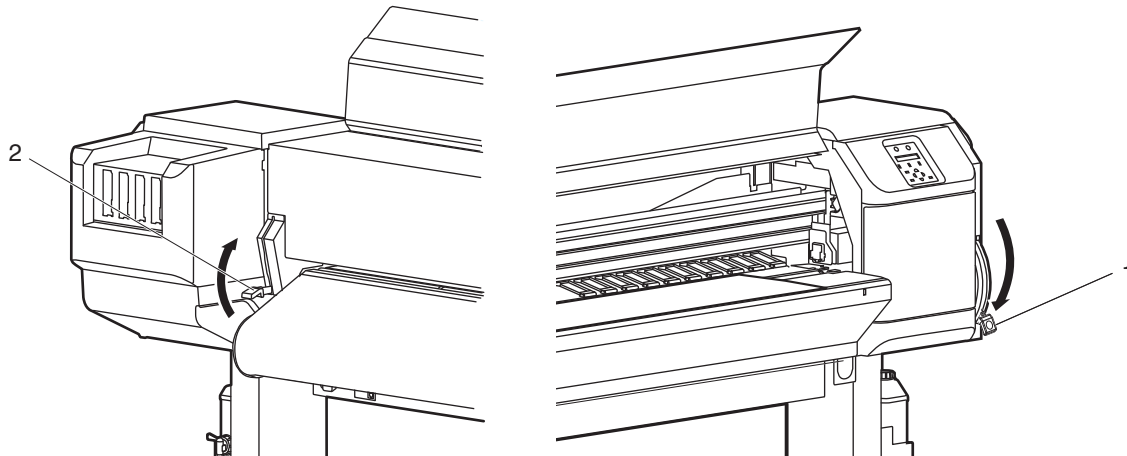

No.	Name
1	Front media loading lever
1	Rear media loading lever

#### NOTE

- Push Front media loading lever down and lower it firmly.  
For Rear media loading lever, push it up firmly.  
If the lever is not firmly lowered or raised, the media may not be detected.
- When loading the new roll media, cut the front edge of the media if it is not straight.  
☞ [4.4.3 Cutting media](#)

10. Close the front cover.

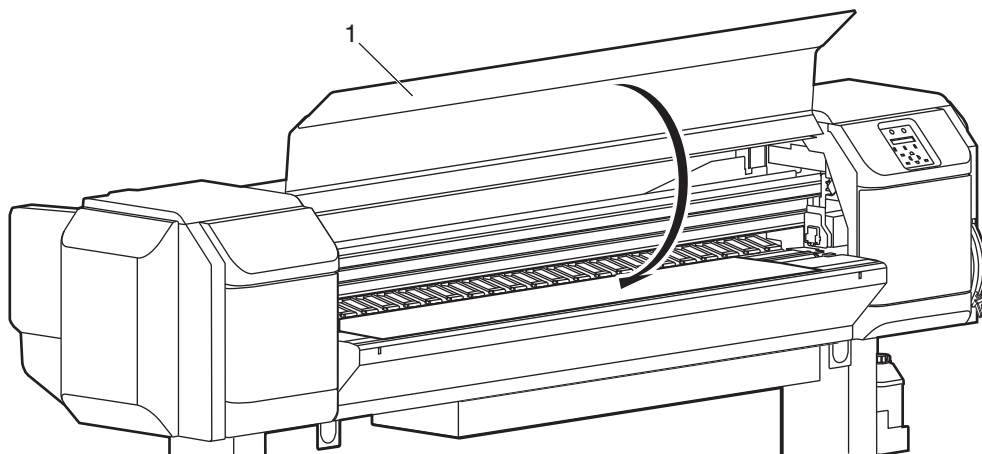

No.	Name
1	Front cover

- The procedure for setting the roll media is complete.
- Set the media type continuously as shown below.  
☞ [3.5.6 Setting media type](#)



### 3.5.6 Setting media type

This section explains how to set the media type.

Follow the procedure below to set the media type.

#### NOTE

After changing the media type, reset the media feed adjustment.

1. Turn ON the printer and load media.
2. In Panel setup menu, check if the media type for the User type you're going to use is appropriately set.
  - ☞ [4.3.2 Menu setup procedure](#)
  - ☞ [5.2.2.10 Rigid/Roll menu](#)

#### NOTE

If the type of the media you have loaded differs from that of the user type you have set, the media may not be detected properly.

3. Load the media.

#### TIP

Refer to the following for loading the media.

•Rigid media:

☞ [3.5.2 Loading rigid media](#)

•Roll media:

☞ [3.5.3 Removing Media-feed table \(optional\)](#) to [3.5.5 Setting roll media](#).

- After the media is loaded, “Media: Type 1 OK?” is displayed.
4. Press the [+] key or [-] key to select the type of the loaded media.

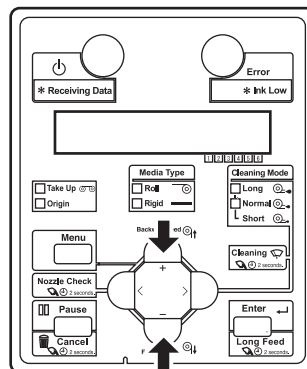

5. Press the [Enter] key.

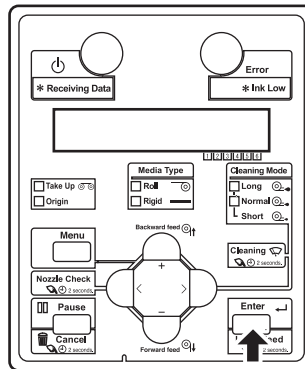

### NOTE

If the following operations are performed in the media type setup menu, the printer starts media initial operation with the media type displayed on the panel.

- Pressing the [Cancel] key.
- No keys are pressed for 10 seconds.

- The media type is set.
- “Head Height Initial” is displayed.
- Head-height initial operation starts.
- The media’s thickness is detected and the optimum distance (setting value of the head height) of the print head from the platen is automatically adjusted.
- “Change: \*.\* mm ->” is displayed.

### CAUTION

- **If the media thickness detection menu is set to “Off”, the head height initial operation is not performed.**  
If “Warning! \*.\* mm ->” is displayed on Operation panel, check if it matches the thickness of the media you have loaded, and if it’s wrong, enter the correct value.
- **If you set a value smaller than the actual media thickness, the media may touch and break Print head.**

### TIP

“\*.\*” indicates the total of the head height value (thickness) and entered correction value (correction).

6. To change value of the head height, press the [+] key or [-] key.

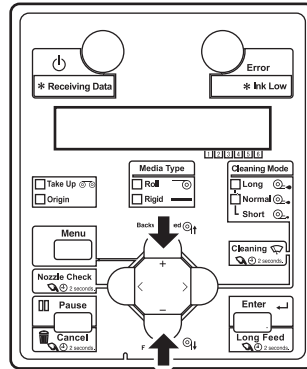

### NOTE

- When using rigid media with a soft printing surface, the head height value displayed may differ from the actual media thickness.  
If this happens, see the following and enter the correction value so that the head height matches the actual media thickness.
- Media thickness detection is a function to keep the gap between Print head and the media, and to stabilize print quality; the measured value may differ from the actual media thickness.

- Remove the rigid media from the printer.
- Measure the media thickness with a tool such as slide gauge.
- Load the rigid media again.
- Enter the difference between the value displayed and the actual media thickness as a correction value.

### TIP

- The total amount of the head height setting value (thickness) and the input adjustment value (adjustment) is displayed in “\*. \*”.
- When you press the [>] key on the operation panel, the setting value (\*.\*) and the input adjustment value (O.O) are each displayed, as in “Thick. + Adj: \*.\* + O.O”.

- Press the [Enter] key.

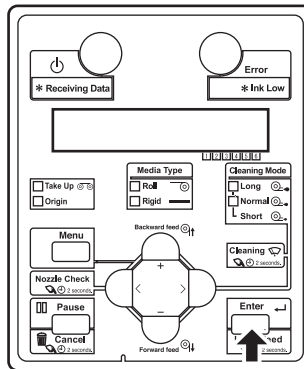

- “Media Initial” is displayed.
- Media initial operation restarts.
- After media initial operation is complete, “Ready to Print” is displayed and shifts to Normal.
- The procedure for setting media type is complete.

### 3.5.7 Media Type Change Procedure from Media Type Menu

This chapter describes the procedure to change the media type from the media type menu.

Check the media thickness detection setting for the User type you want to use, and then read the appropriate procedure.

[5.2.2.7.1 Media thickness detection \(media initial 1\)](#)

#### 3.5.7.1 When the media thickness detection is ON

If the media thickness detection is set to ON, follow the procedure below.

- Press the [Menu] key.

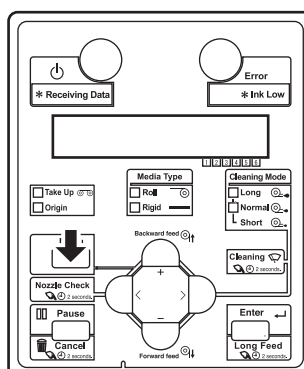

- “Menu1: Sleep Mode>” is displayed.

Menu1 : Sleep Mode>

2. Press the [+] or [-] key to select “Menu2: User Type>”.

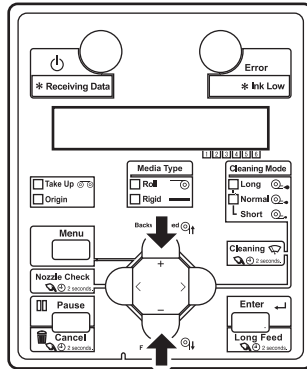

3. Press the [>] key.

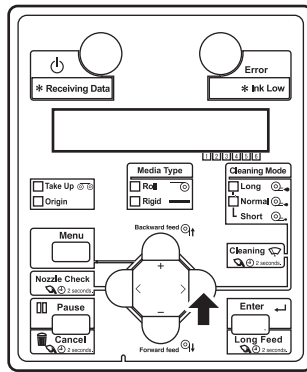

- “User: Type 1” is displayed.

User : Type 1

4. Press the [+] key or [-] key to select the user type to use.

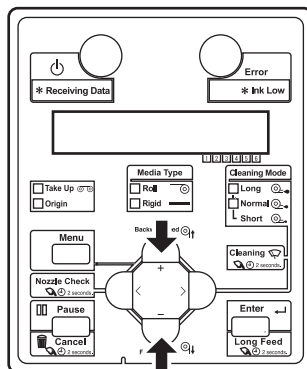

- Press the [Enter] key.

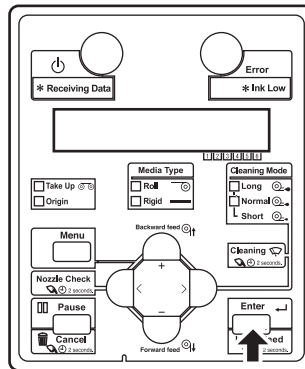

- After the user type is changed, “Paper Thick Changed?” is displayed.

Paper Thick Changed?

#### NOTE

When the same media type as last time is selected, “\*\*>1: Print Mode” is displayed. Exit this procedure, and then the setting of user media can be specified.

[5.2.2 Various settings of User type](#)

- Press the [Enter] key.

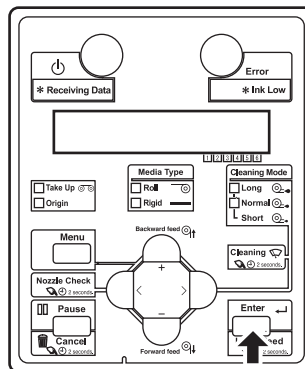

- The media thickness registered for the selected media type will be updated to the media thickness currently set.
- “\*\*>1: Print Mode” is displayed.

\*\*>1 Print Mode

- Then, various settings for user media can be specified.

[5.2.2 Various settings of User type](#)

### 3.5.7.2 When the media thickness detection is OFF

If the media thickness detection is set to OFF, follow the procedure below.

1. Press the [Menu] key.

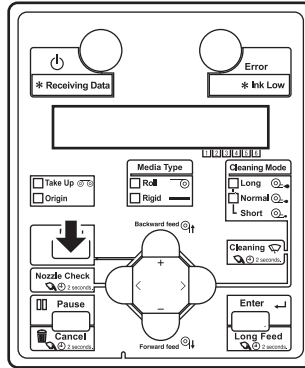

- “Menu 1: Sleep Mode>” is displayed.

Menu 1 :      S l e e p   M o d e >

2. Press the [+] or [-] key to select “Menu2: User Type>”.

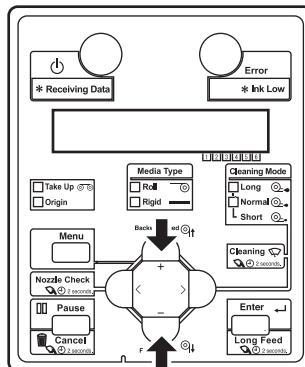

3. Press the [>] key.

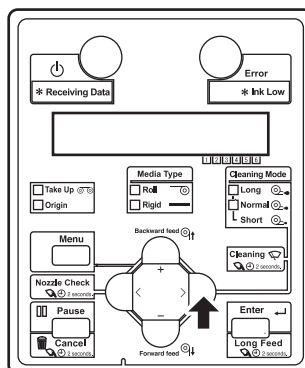

- “User: Type 1” is displayed.

U s e r :                      T y p e   1

4. Press the [+] key or [-] key to select the user type to use.

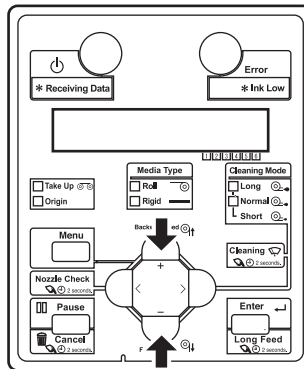

5. Press the [Enter] key.

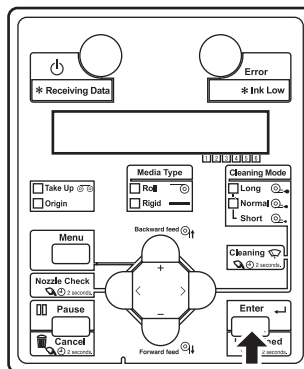

- When the media type is changed to a different media type (contents of user media is already set), “Warning! \*.\*mm ->” is displayed.

Warning! \*.\*mm ->

#### NOTE

- When a new media type (content of user media is not set) is selected, the printer detects the media thickness. Go to the procedure 8 (b).
- When the same media type as previous is selected, “\*\*>1: Print Mode” is displayed. Exit this procedure, and then the setting of user media can be specified.

[5.2.2 Various settings of User type](#)

#### TIP

- The total amount of the head height setting value (thickness) and the input adjustment value (adjustment) is displayed in “\*.\*”.
- When you press the [>] key on the operation panel, the setting value (\*.\*) and the input adjustment value (O.O) are each displayed, as in “Thick. + Adj: \*.\* + O.O”.



6. Check if the media thickness displayed is same as the specified media thickness.
  - a. If the media thickness is correct, press the [Enter] key.

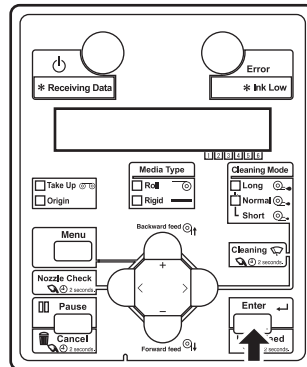

- “Misuse Damage Unit >” is displayed.

M i s u s e   D a m a g e   U n i t >

### CAUTION

- **If you set a value smaller than the actual media thickness, the media may touch and break Print head.**

- b. If it is wrong, press the [Cancel] key; media thickness is detected. Skip to step 8 (b).
7. Press and hold the [>] key.

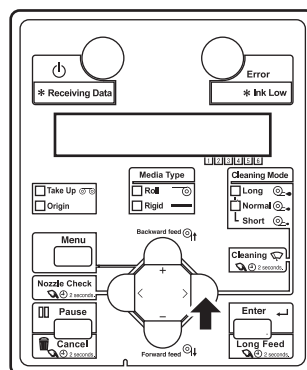

- “<E>Skip,<CAN>Detect” is displayed.

< E > S k i p , < C A N > D e t e c t

8. Select whether to detect the media thickness.
  - a. To skip the media thickness detection, press the [Enter] key.

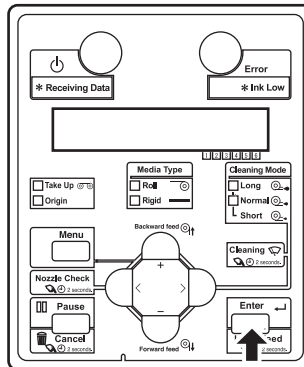

- The printer performs media initialization (The media thickness will not be detected).
- “Ready to Print” is displayed.

R e a d y   t o   P r i n t

- Terminate the procedure to change the media type.
- b. To detect the media thickness, press the [Cancel] key.

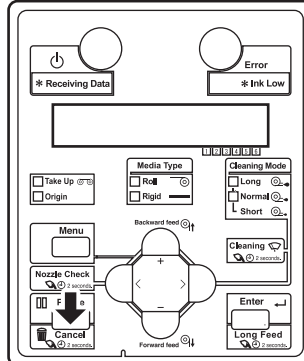

- “Media Initial” is displayed.

M e d i a   I n i t i a l

- Head-height initial operation starts.
- The media's thickness is detected and the optimum distance (setting value of the head height) of the print head from the platen is automatically adjusted.
- “Change: \*.\* mm ->” is displayed.

C h a n g e :            \* . \* m m - >

**TIP**

- The total amount of the head height setting value (thickness) and the input adjustment value (adjustment) is displayed in “\*.\*.\*”.
- When you press the [>] key on the operation panel, the setting value (\*.\*) and the input adjustment value (O.O) are each displayed, as in “Thick. + Adj: \*.\* + O.O”.

9. To change the setting value for the head height, press the [+] key or [-] key and change the setting value.

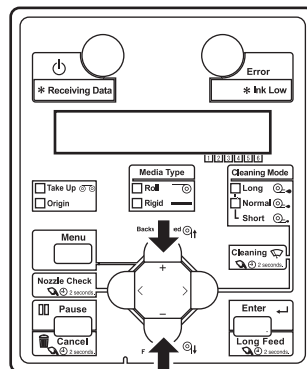
**NOTE**

- If the printing side of the thick media is soft, the head height setting value displayed and the actual thickness of the media may differ. In this case, follow the steps below to input the correct value so that the head height is aligned with the actual thickness of the media.
  - Media thickness detection is a function to keep the gap between Print head and the media, and to stabilize print quality; the measured value may differ from the actually media thickness.
- a. Remove the media from the printer.
  - b. Measure the media's thickness with calipers or similar tool.
  - c. Set the thick media again.
  - d. Input the difference of the setting value displayed and the actual thickness as the adjustment value.

10. Press the [Enter] key.

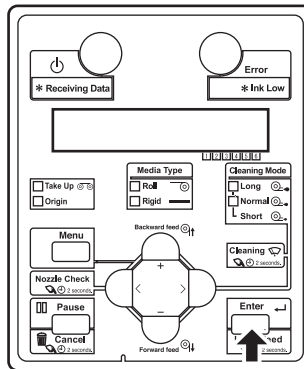

- "Media Initial" is displayed.

Media Initial

- Media initial operation restarts.
- After media initial operation is complete, "Ready to Print" is displayed and the display shifts to Normal.

Ready to Print

- The procedure for setting media type is complete.

## 3.6 Test print

Follow the procedure below to perform Test printing to confirm that the printer works correctly.

### CAUTION

- **Do not touch UV curable ink with bare hands prior to ink curing.**  
Skin or eye contact with UV curable ink may cause skin inflammation or allergic reaction.
- **Wear protective gloves, goggles and/or face shield, and clothing while using of the printer.**

 [6.1 Wearing the gloves and goggles](#)

1. Turn ON the printer and load the roll media.  
 [3.5.5 Setting roll media](#)
2. Confirm that the printer functions normally.
3. Display the Test print menu.
  - a. Press the [Menu] key.

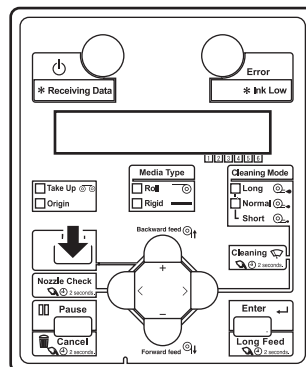

- “Menu 1: Sleep Mode>” is displayed.
- b. Press the [+] key or [-] key to select “Menu4: Test Print>”.

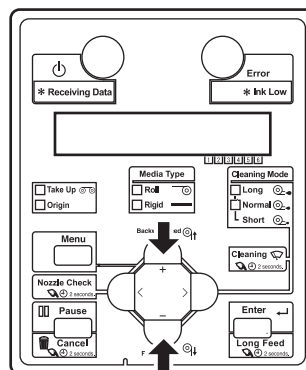

- c. Press the [>] key.

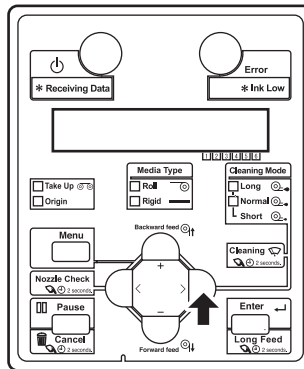

- “Test1: Nozzle Check” is displayed.
- The display shifts to the Test print menu.

[5.4 TestPrint Menu](#)

4. Press the [+] key or [-] key to select an item for printing from the following items.

- Nozzle check
- Nozzle check B
- Mode print
- Setup List
- Palette

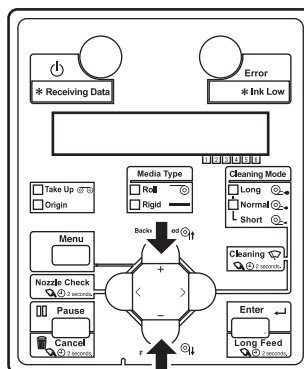

**NOTE**

- When “Banner 1” is set in the Print Mode menu, “PalettePrint” is not displayed in the Test Print menu.  
 [5.4 TestPrint Menu](#)
- When using the 4-color set, the item for “Nozzle check B” is not displayed.

5. Press the [Enter] key.

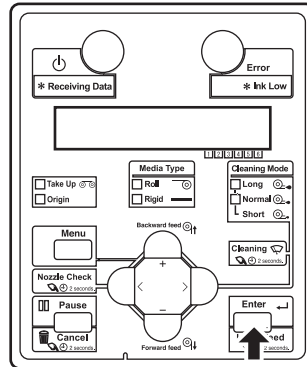

- Start performing Test Print for the selected item.

**TIP**

Refer to the following for details on each of the print list items.

☞ [3.6.1 Nozzle check](#) to [3.6.5 Palette print](#)

6. Repeat step 4 to step 5 when performing test print for other items.
7. Press the [Cancel] key to exit from Test print menu.

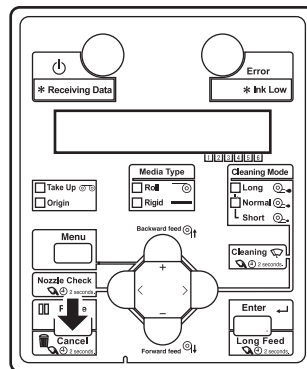

- The operation panel returns to Normal.
- The procedure for test printing is complete.

### 3.6.1 Nozzle check

It is used to check whether there are any clogged heads, or missing or blurred prints.

#### NOTE

If the nozzle check result indicates that the checked points are blurred or missing, perform Head cleaning.

 [6.5.2 Head cleaning](#)

Perform the nozzle check once again at the end of the work.

#### TIP

- The printer information (date and time of printing, printer's serial number, firmware version) is printed on the nozzle check pattern.

- Refer to the following for printing procedure.

 [3.6 Test print](#)

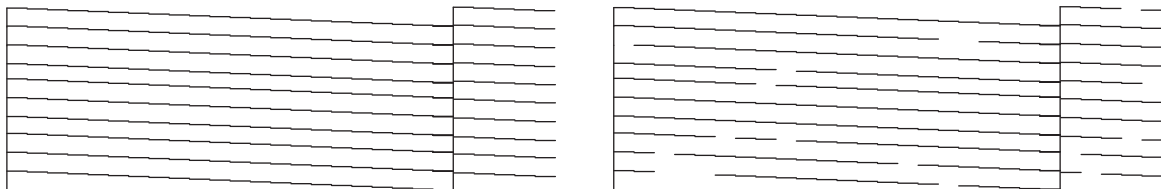



### 3.6.2 Nozzle check B

This is nozzle check for white ink.

The background of the nozzle check pattern will be colored so that white ink can be seen.

#### NOTE

If the nozzle check result shows that the checked points are blurred or missing, perform Head cleaning.

 [6.5.2 Head cleaning](#)

Perform the nozzle check once again at the end of the work.

#### TIP

- The printer information (date and time of printing, printer's serial number, firmware version) is printed on the nozzle check pattern.

- Refer to the following for printing procedure.

 [3.6 Test print](#)

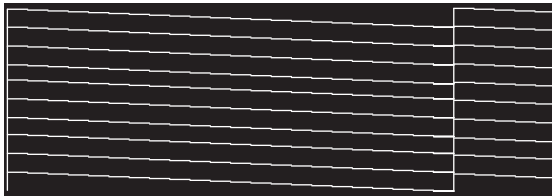

### 3.6.3 Mode print

Used to confirm the following printing conditions.

- Print Mode
- Effect
- Adjustment value

**TIP**

Refer to the following for printing procedure.

 [3.6 Test print](#)

---

2014/03/01 0:00 Q2(1440x1440N 16Pass Bi)- i-Weave UV/PF Adjust:0.00%

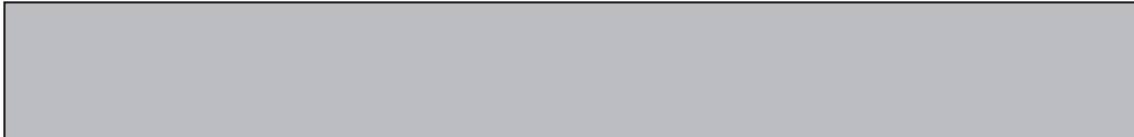

### 3.6.4 Setup print

Used to check the current setup of the printer.

**NOTE**

Keep the created print setup parameters at hand.

**TIP**

Refer to the following for printing procedure.

[3.6 Test print](#)

#### Setup List

<Information>		2014/03/01 0:00	
SerialNo	= *****	Firmware M	= V**
Model	= VJ-1626UH	Firmware H	= V.1.00
Memory Size	= 384MB	Error!	0:None [ ] 2:None [ ] 4:None [ ] 1:None [ ] 3:None [ ] 5:None [ ]
<Menu Setup>		Cleaning mode: Normal	
[Number]Select Menu	= Setup	[Sleep Mode]	
[Setup]		[1] SleepModeTimer = Off	
[1]Side Margin	= 5mm	[2] Type = Off	
[2]Take-up	= Off	[User Type]	
[3]Media Location	= Off	User = Type 30	
[4]Origin	= Off	[1]Print Mode = Banner 1(Effect = i-Weave UV)	
[5]Head Travel	= Data	[2]Adjust Print = 250.0/250mm	
[6]Multi Strike	= 1cnt	[3]Confirm Adj.Print	
Layer Multi Strike		[4]Micro Adj. Print	
[1]Color	= 4cnt	[5]Media Adjust = 0.00%	
[2]White	= 6cnt	[4]Vacuum Fan = High	
[3]Varnish	= 3cnt	[5]Thickness = 0.3mm	
[7]Slant Check	= Off	[6]Thick Adjust. = 0.0mm	
[8]Auto Cleaning		[7]Media initial	
[1]Waiting		[1]Height = On	
[1]Type = Short		[2]Media = Width	
[2]Time = 6h		[8]Media Width = 1625mm	
[2]Printing		[9]Pass Wait = 0.0sec	
[1]Type = Off		[10]Rigid/Roll = Roll	
[2]Tm = 6h		[11]Show Edges = Off	
[3]Before Print = Off		[12]Initial	
[9]Rollkind = Off		[13]Add Y Layer = Roll	
[10]FrontInterface = Auto		[Initial]	
[11]BtmInterface = On		[1]Language = English	
[12]CR Maintenance		[2]Length = mm	
[13]Ink Status		[3]IP Address = 192.168.001.253	
SmartChip 1234:92/36/100/53		[4]Subnet Mask = 255.255.255.000	
56 : 79/100		[5]Gateway = 192.168.001.254	
[14]Life Times		[6]Alert Buzzer = On	
Head : E*****F		[Maintenance]	
Pump : E*****F		[1]Ink Discharge	
CR Motor : E*****F		[2]Plug Life	
PF Motor : E*****F		[1]Confirm	Slot1 : E*****F
CPump : E*****F			Slot2 : E*****F
UV LED : E*****F			Slot3 : E*****F
[15]Header Dump = Off			Slot4 : E*****F
[16]Exhaust Fan = Low			Slot5 : E*****F
[17]White Maitre. = Normal			Slot6 : E*****F
[18]Start Feed = 0mm			
[19]Initialization			
[20]Spitting = On(Pass Count = 1cnt)		[2]Init.	

#### <Media Type List>

User Type	Type 1	Type 2	Type 3	Type 4	Type 5	Type 6	Type 7	Type 8	Type 9	Type 10
Print Mode	Graphics 2	Graphics 2	Graphics 2	Graphics 2	Graphics 2	Graphics 2	Graphics 2	Graphics 2	Graphics 2	Graphics 2
Print Mode>Effect	i-Weave UV	i-Weave UV	i-Weave UV	i-Weave UV	i-Weave UV	i-Weave UV	i-Weave UV	i-Weave UV	i-Weave UV	i-Weave UV
PF->Initial Adjust	500.9/500mm	500.9/500mm	500.9/500mm	500.9/500mm	500.9/500mm	500.9/500mm	500.9/500mm	500.9/500mm	500.9/500mm	500.9/500mm
PF->Micro Adjust	0.00%	0.00%	0.00%	0.00%	0.00%	0.00%	0.00%	0.00%	0.00%	0.00%
Vacuum Fan	High	High	High	High	High	High	High	High	High	High
Thickness	0.3mm	0.3mm	0.3mm	0.3mm	0.3mm	0.3mm	0.3mm	0.3mm	0.3mm	0.3mm
Thickness Ajst.	0.0mm	0.0mm	0.0mm	0.0mm	0.0mm	0.0mm	0.0mm	0.0mm	0.0mm	0.0mm
Media Initial>Height	On	On	On	On	On	On	On	On	On	On
Media Initial>Paper	Width	Width	Width	Width	Width	Width	Width	Width	Width	Width
Media Width	1625mm	1625mm	1625mm	1625mm	1625mm	1625mm	1625mm	1625mm	1625mm	1625mm
Pass Wait	0.0sec	0.0sec	0.0sec	0.0sec	0.0sec	0.0sec	0.0sec	0.0sec	0.0sec	0.0sec
Rigid/Roll	Roll	Rigid	Roll	Rigid	Roll	Rigid	Roll	Rigid	Roll	Rigid
Show Edges	Off	Off	Off	Off	Off	Off	Off	Off	Off	Off
User Type	Type 11	Type 12	Type 13	Type 14	Type 15	Type 16	Type 17	Type 18	Type 19	Type 20
Print Mode	Graphics 2	Graphics 2	Graphics 2	Graphics 2	Graphics 2	Graphics 2	Graphics 2	Graphics 2	Graphics 2	Graphics 2
Print Mode>Effect	i-Weave UV	i-Weave UV	None	i-Weave UV	None	i-Weave UV	None	i-Weave UV	None	i-Weave UV
PF->Initial Adjust	500.9/500mm	500.9/500mm	500.9/500mm	500.9/500mm	500.9/500mm	500.9/500mm	500.9/500mm	500.9/500mm	500.9/500mm	500.9/500mm
PF->Micro Adjust	0.00%	0.00%	0.00%	0.00%	0.00%	0.00%	0.00%	0.00%	0.00%	0.00%
Vacuum Fan	High	High	High	High	High	High	High	High	High	High
Thickness	0.3mm	0.3mm	0.3mm	0.3mm	0.3mm	0.3mm	0.3mm	0.3mm	0.3mm	0.3mm
Thickness Ajst.	0.0mm	0.0mm	0.0mm	0.0mm	0.0mm	0.0mm	0.0mm	0.0mm	0.0mm	0.0mm
Media Initial>Height	On	On	On	On	On	On	On	On	On	On
Media Initial>Paper	Width	Width	Width	Width	Width	Width	Width	Width	Width	Width
Media Width	1625mm	1625mm	1625mm	1625mm	1625mm	1625mm	1625mm	1625mm	1625mm	1625mm
Pass Wait	0.0sec	0.0sec	0.0sec	0.0sec	0.0sec	0.0sec	0.0sec	0.0sec	0.0sec	0.0sec
Rigid/Roll	Roll	Rigid	Roll	Rigid	Roll	Rigid	Roll	Rigid	Roll	Rigid
Show Edges	Off	Off	Off	Off	Off	Off	Off	Off	Off	Off
User Type	Type 21	Type 22	Type 23	Type 24	Type 25	Type 26	Type 27	Type 28	Type 29	Type 30
Print Mode	Graphics 2	Graphics 2	Graphics 2	Graphics 2	Graphics 2	Graphics 2	Graphics 2	Graphics 2	Graphics 2	Graphics 2
Print Mode>Effect	i-Weave UV	i-Weave UV	i-Weave UV	i-Weave UV	i-Weave UV	i-Weave UV	i-Weave UV	i-Weave UV	i-Weave UV	i-Weave UV
PF->Initial Adjust	500.9/500mm	500.9/500mm	500.9/500mm	500.9/500mm	500.9/500mm	500.9/500mm	500.9/500mm	500.9/500mm	500.9/500mm	500.9/500mm
PF->Micro Adjust	0.00%	0.00%	0.00%	0.00%	0.00%	0.00%	0.00%	0.00%	0.00%	0.00%
Vacuum Fan	High	High	High	High	High	High	High	High	High	High
Thickness	0.3mm	0.3mm	0.3mm	0.3mm	0.3mm	0.3mm	0.3mm	0.3mm	0.3mm	0.3mm
Thickness Ajst.	0.0mm	0.0mm	0.0mm	0.0mm	0.0mm	0.0mm	0.0mm	0.0mm	0.0mm	0.0mm
Media Initial>Height	On	On	On	On	On	On	On	On	On	On
Media Initial>Paper	Width	Width	Width	Width	Width	Width	Width	Width	Width	Width
Media Width	1625mm	1625mm	1625mm	1625mm	1625mm	1625mm	1625mm	1625mm	1625mm	1625mm
Pass Wait	0.0sec	0.0sec	0.0sec	0.0sec	0.0sec	0.0sec	0.0sec	0.0sec	0.0sec	0.0sec
Rigid/Roll	Roll	Rigid	Roll	Rigid	Roll	Rigid	Roll	Rigid	Roll	Rigid
Show Edges	Off	Off	Off	Off	Off	Off	Off	Off	Off	Off

### 3.6.5 Palette print

Palette print is executed for the color demonstration.

**NOTE**

When “Banner 1” is set in the Print Mode menu, “PalettePrint” is not displayed in the Test Print menu.

[5.4 TestPrint Menu](#)

**TIP**

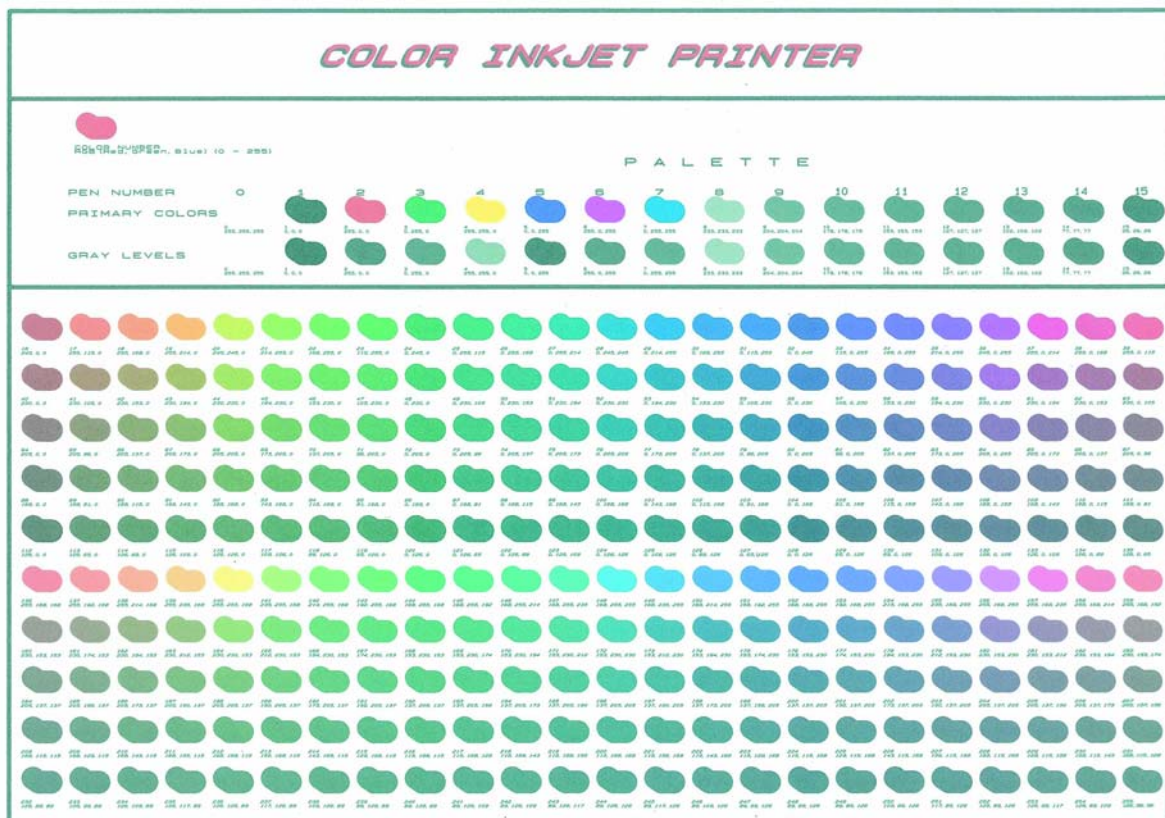

Refer to the following for printing procedure.

[3.6 Test print](#)



## 3.7 Adjust print

It is used for optimizing the quality of image prints.  
Adjustment methods for this printer are as follows.



Adjustment method	Description	Reference
Standard	Adjustment is performed only for the print mode used by the current User Type. When using Standard for adjustment, set the resolution of the print mode, number of passes, and print direction on the RIP side as same as those of User Type print mode.	 <a href="#">3.7.1 Standard print quality adjustment</a>
Custom	Adjustment can also be performed with the print mode other than the mode used by the current User Type. Even if the print mode on the RIP side differs from the mode used by the User Type, you can optimize print quality.	 <a href="#">3.7.2 Custom print quality adjustment</a>

### NOTE



- If print quality has declined after changing the installation environment or the media you are using, perform print quality adjustment.
- After performing the standard print quality adjustment and you want to change the print mode, make sure that you also perform print quality adjustment.
- Since all print modes are adjusted at once after performing Custom adjust print, adjust print is not required even after changing the print mode.
- When specifying a print mode for RIP software, etc, that is different from the mode set in the user type setting, perform custom head adjustment and check all patterns (A to F), and then adjust any patterns that are misaligned beforehand.

### 3.7.1 Standard print quality adjustment

Adjusts only the print mode in the user type setting which is currently set.  
This menu consists of the following menus.

Menu name		Description	Reference
Adj. Print1 : Standard	Confirm ptn.	Print out the confirmation pattern and check the degree of misalignment.	 <a href="#">3.7.1.1 Standard confirmation pattern</a>
	Rough Pattern	Perform this when the degree of misalignment is large.	 <a href="#">3.7.1.2 Standard rough adjustment pattern</a>
	Fine Pattern	Perform this when the degree of misalignment is small.	 <a href="#">3.7.1.3 Standard fine adjustment pattern</a>

Follow the procedure below to perform adjustment.

1. Print out the confirmation pattern and check the degree of misalignment.  
 [3.7.1.1 Standard confirmation pattern](#)
2. Perform rough adjustment when the degree of misalignment is large.  
 [3.7.1.2 Standard rough adjustment pattern](#)  
Perform micro adjustment when the degree of misalignment is small.  
 [3.7.1.3 Standard fine adjustment pattern](#)

#### NOTE

Perform rough adjustment first when the degree of misalignment is difficult to determine.

3. Print out the confirmation pattern again and check if the printer has been adjusted properly.  
 [3.7.1.1 Standard confirmation pattern](#)
4. If it has not been adjusted yet, return to step 2.

#### NOTE

Perform micro adjustment if the printer is not fully adjusted after rough adjustment.

### 3.7.1.1 Standard confirmation pattern

Print out the confirmation pattern of the print mode in the user type setting which is currently set.

1. Turn ON the printer and load the roll media.

 [3.5.5 Setting roll media](#)

2. Display the Printing mode menu.
  - a. Press the [Menu] key.

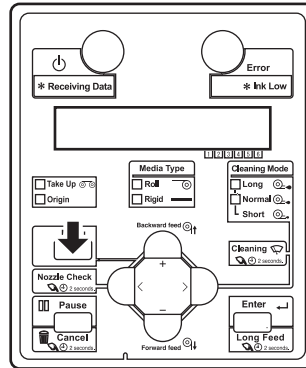

- “Menu 1: Sleep Mode>” is displayed.

- b. Press the [+] key or [-] key to select the “Menu 2: User Type>”.

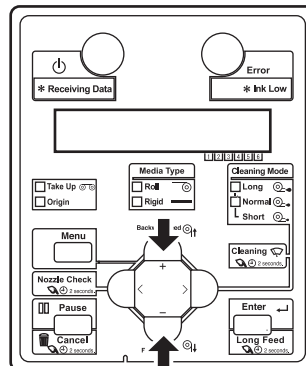

- c. Press the [>] key.

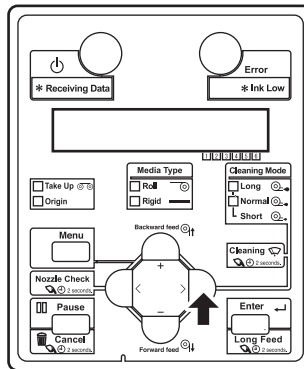

- “User: Type XX” (XX is a number between 1 and 30) is displayed.

- d. Press the [+] key or [-] key to select the user type to use.

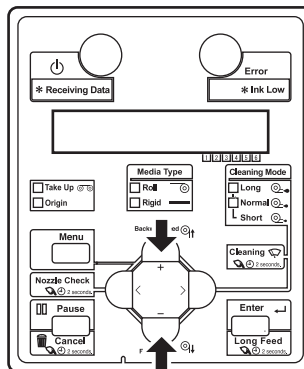

- e. Press the [Enter] key.

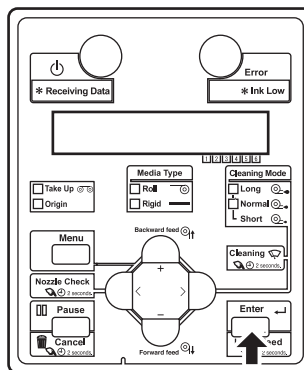

- “\*\*>1: Print Mode” is displayed.



## TIP

- The selected media (Type 1 to 30) is displayed in \*\*.
- ☞ 5.2.1 Type menu
- If you set the User type different from the previous time when the Media detection is set to On, “Change Media Thickness?” is displayed.
  - Press the [Enter] key to overwrite the detected media thickness with the User type you have set here.
  - Press the [Cancel] key to return to the selection screen of User type.

- f. Press the [+] key or [-] key to select the “\*\*>2: Adjust Print>”.

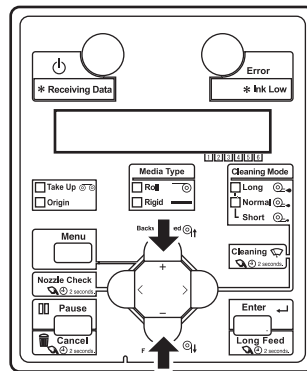

- g. Press the [>] key.

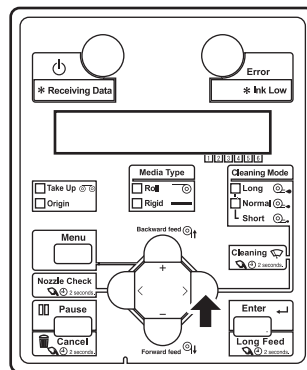

- “Adj. Print1: Standard” is displayed.

- h. Press the [Enter] key.

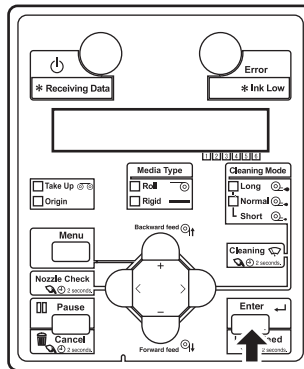

- “Adj.1: Confirm Ptn.” is displayed.
- The display shifts to Adjust Print menu.  
[5.2.2.2 Adjust Print menu](#)

3. Press the [Enter] key.

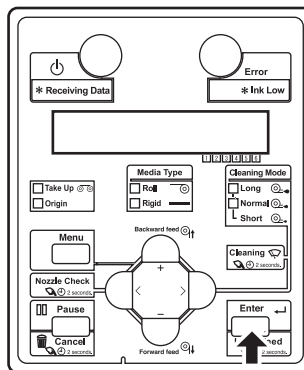

- A confirmation pattern will be printed.

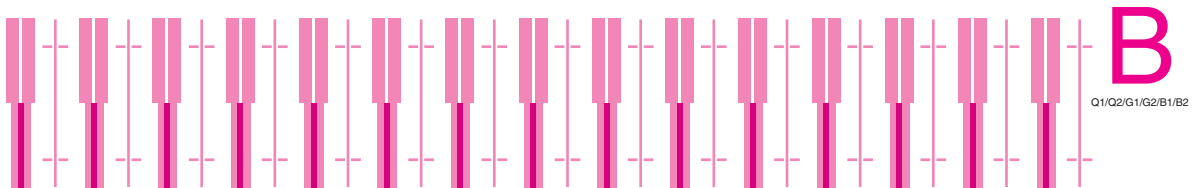

- After the confirmation pattern is printed, the operation panel shifts to “Adj.1 Confirm Ptn.”

4. Confirm that the confirmation pattern print result is as follows.

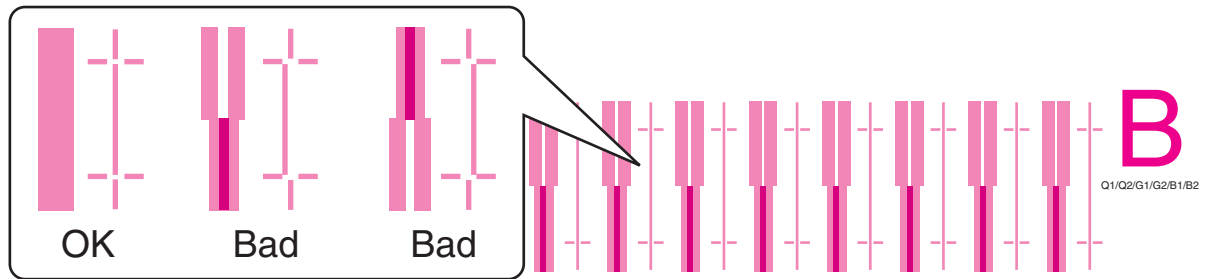

- a. When the print result is “OK”:  
You do not need perform Alignment.  
The procedure for Alignment is complete.
- b. When the print result is “Bad”:  
You need to perform Alignment.
  - Perform rough adjustment when the degree of misalignment is large.  
[👉 3.7.1.2 Standard rough adjustment pattern](#)
  - Perform micro adjustment when the degree of misalignment is small.  
[👉 3.7.1.3 Standard fine adjustment pattern](#)

### 3.7.1.2 Standard rough adjustment pattern

Perform rough adjustment when the degree of misalignment is large.  
Print rough adjustment pattern and register the set values.

1. Display the Standard Adjust Print menu in the same way as step 2 of [3.7.1.1 Standard confirmation pattern](#).
2. Press the [+] key or [-] key to select “Adj.2: Rough Pattern”.

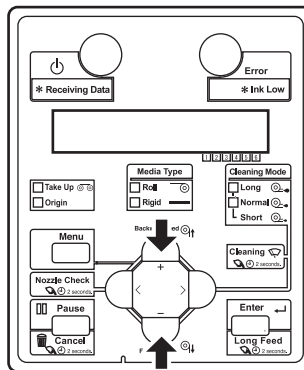

3. Press the [Enter] key.

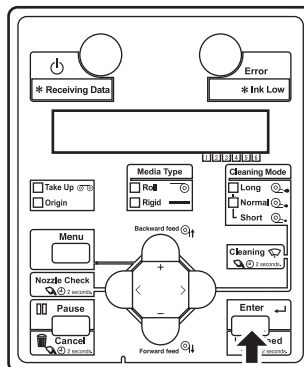

- A rough adjustment pattern will be printed.

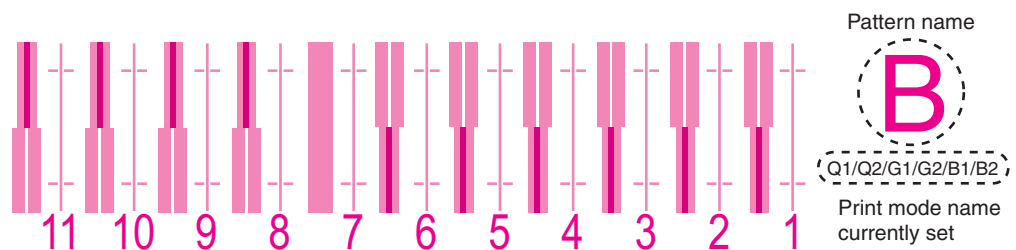

- For the rough adjustment pattern, the same patterns will be printed on both sides and center of the media.
- “PatternB: 6” is displayed.

- Check the print results on both sides and center of the media and select the number that looks most aligned between 1 and 11.  
 “7” is selected in the next printing sample.

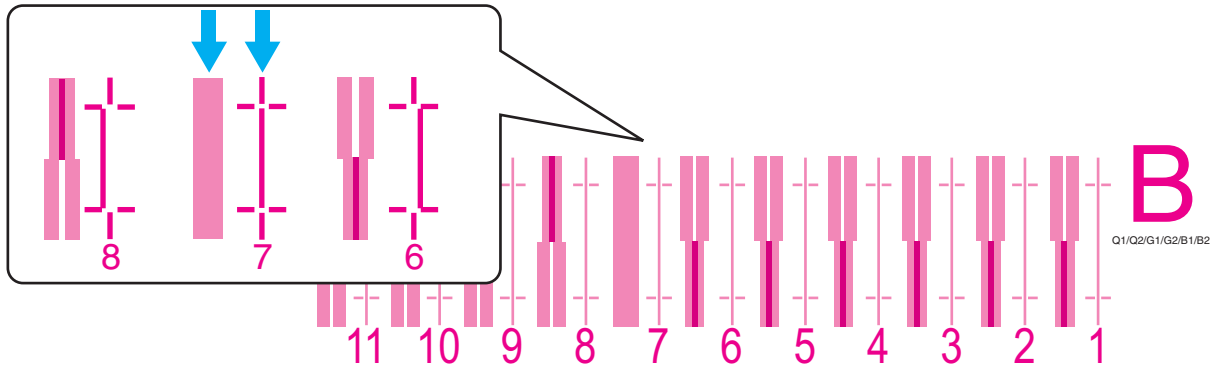

**NOTE**

“6” represents the current setting value.

- Press the [+] key or [-] key to enter the number that you selected in Step 4.

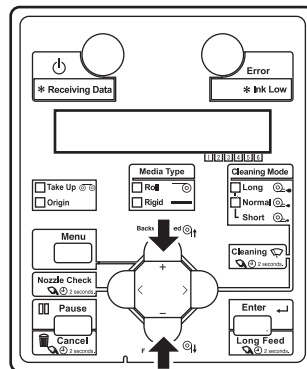

**NOTE**

When you press the [Cancel] key on Operation panel, the display returns to “Adj.2: Rough Pattern”.

6. Press the [Enter] key.

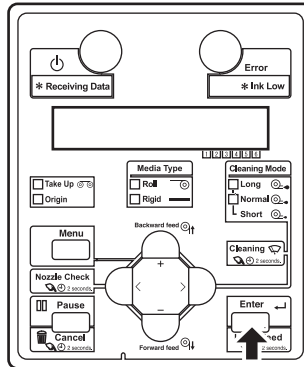

- Determines the setting.
- The operation panel returns to “Adj.2: Rough Pattern”.

### 3.7.1.3 Standard fine adjustment pattern

Perform micro adjustment when the degree of misalignment is small.  
Print micro adjustment pattern and register the set values.

1. Display the Standard Adjust Print menu in the same way as step 2 of [3.7.1.1 Standard confirmation pattern](#).
2. Press the [+] key or [-] key to select “Adj.3: Fine Pattern”.

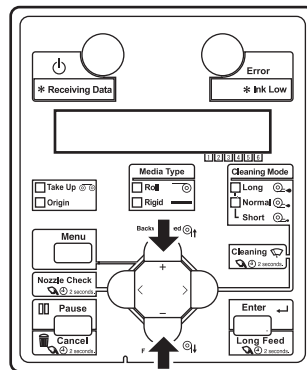

3. Press the [Enter] key.

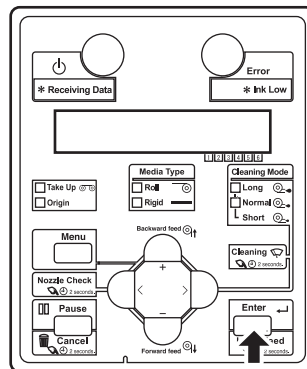

- A fine adjustment pattern will be printed.

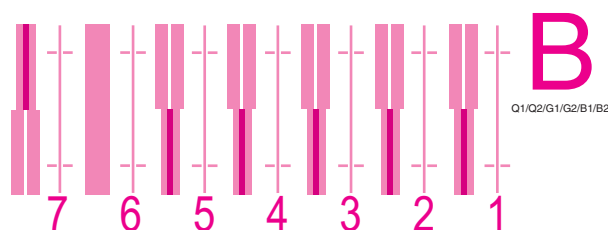

- For the fine adjustment pattern, the same patterns will be printed on both sides and center of the media.
- “PatternB: 4” is displayed.

4. Check the print results on both sides and center of the media and select the number that looks most aligned between 1 and 7.
  - “6” is selected in the next printing sample.

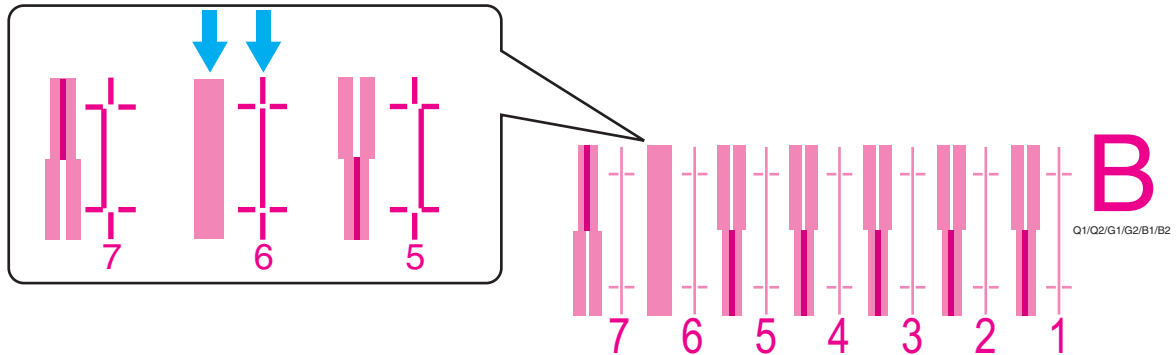
**NOTE**

“4” represents the current setting value.

5. Press the [+] key or [-] key to enter the number that you selected in Step 4.

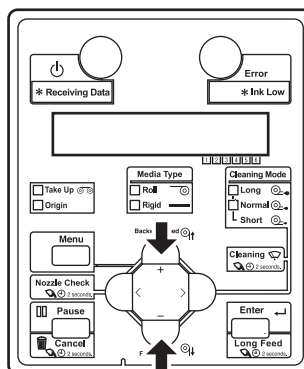
**NOTE**

When you press the [Cancel] key on Operation panel, the display returns to “Adj.3: Fine Pattern”.



6. Press the [Enter] key.

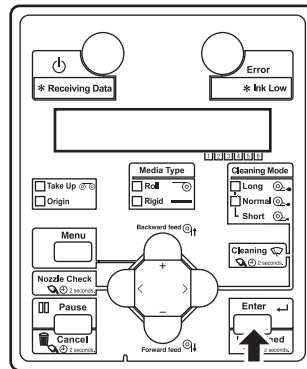





- Determines the setting.
- The operation panel returns to “Adj.3: Fine Pattern”.

### 3.7.2 Custom print quality adjustment



Perform adjustment for all patterns (A to F).

All print modes will be adjusted.

This menu consists of the following menus.

Menu name		Description	Reference
Adj. Print2 : Custom	Confirm ptn.	Print out the confirmation patterns (A to F) and check the degree of misalignment.	 <a href="#">3.7.2.1 Custom confirmation pattern</a>
	Rough Ptn. ALL	Perform this when the degree of misalignment is large. All confirmation patterns (A to F) will be adjusted.	 <a href="#">3.7.2.2.1 Rough Ptn. ALL</a>
	Rough PatternA to F	Perform this when the degree of misalignment is large. One of the confirmation patterns (A to F) will be adjusted.	 <a href="#">3.7.2.2.2 Rough Pattern A to F</a>
	Fine Ptn. ALL	Perform this when the degree of misalignment is small. All confirmation patterns (A to F) will be adjusted.	 <a href="#">3.7.2.3.1 Fine Ptn. ALL</a>
	Fine PatternA to F	Perform this when the degree of misalignment is small. One of the confirmation patterns (A to F) will be adjusted.	 <a href="#">3.7.2.3.2 Fine Pattern A to F</a>

Follow the procedure below to perform adjustment.

1. Print out the confirmation pattern and check the degree of misalignment.  
 [3.7.2.1 Custom confirmation pattern](#)
2. Perform rough adjustment when the degree of misalignment is large.  
 [3.7.2.2 Custom rough adjustment pattern](#)  
Perform micro adjustment when the degree of misalignment is small.  
 [3.7.2.3 Custom fine adjustment pattern](#)

#### NOTE

- Perform rough adjustment first when the degree of misalignment is difficult to determine.
- Perform adjustment for A to F patterns if they are misaligned.

3. Print out the confirmation pattern again and check if the printer has been adjusted properly.  
 [3.7.2.1 Custom confirmation pattern](#)
4. If it has not been adjusted yet, return to Step 2.

**NOTE**

- Perform micro adjustment if the printer is not fully adjusted after rough adjustment.
- In adjustment patterns, there are “Rough adjustment pattern ALL”, “Fine adjustment ALL” in which you can adjust all patterns, and “Rough adjustment pattern A to F” and “Fine adjustment patterns A to F” in which you can adjust A to F patterns individually.

**3.7.2.1 Custom confirmation pattern**

Using this menu, you can print out all of the confirmation patterns (A to F) and check the degree of misalignment.

1. Turn ON the printer and load the roll media.

[3.5.4 Loading roll media](#)

2. Display the Adjust Print menu.

- a. Press the [Menu] key.

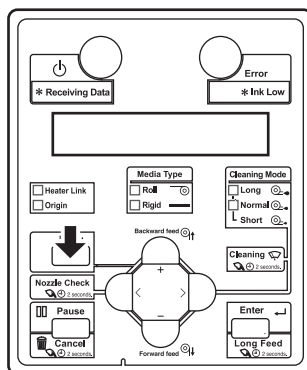

- “Menu1: Sleep Mode>” is displayed.
- b. Press the [+] key or [-] key to select “Menu2: User Type>”.

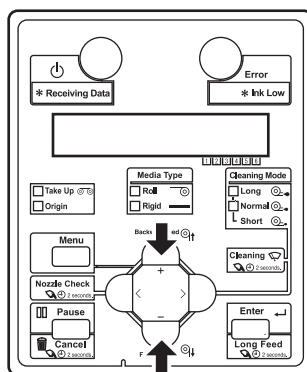

- c. Press the [>] key.

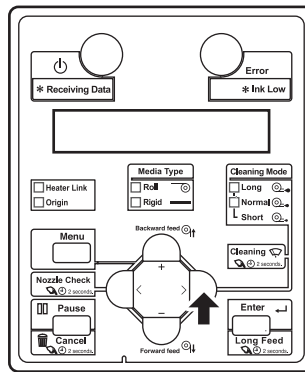

- “User: TypeXX” (XX is a number between 1 and 30) is displayed.
- d. Press the [+] key or [-] key to select the user type setting.
- e. Press the [Enter] key.

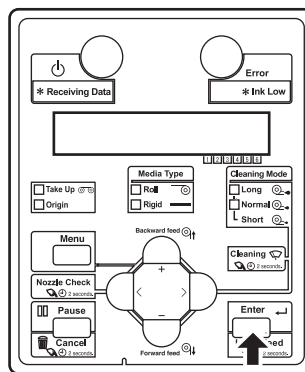

- “\*\*>1: Print Mode” is displayed.
- f. Press the [+] key or [-] key to select “\*\*>2: Adjust Print”.

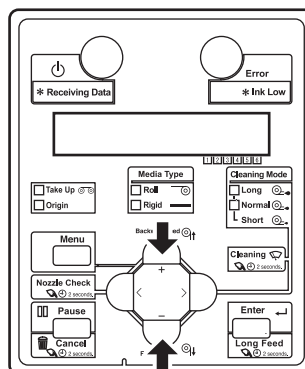

- g. Press the [>] key.

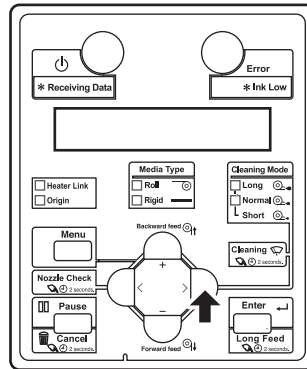

- “Adj. Print1: Standard” is displayed.

- h. Press the [+] key or [-] key to select “Adj Print2: Custom”.

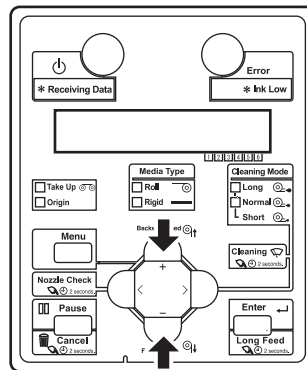

- i. Press the [Enter] key.

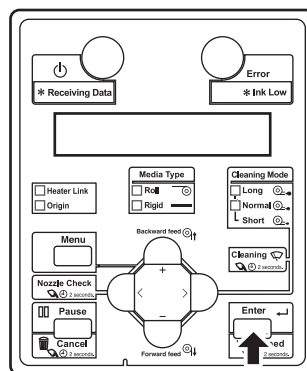

- “Adj.1: Confirm” is displayed.
- The display enters the Adjust Print menu.

[5.2.2.2 Adjust Print menu](#)

- Press the [Enter] key.

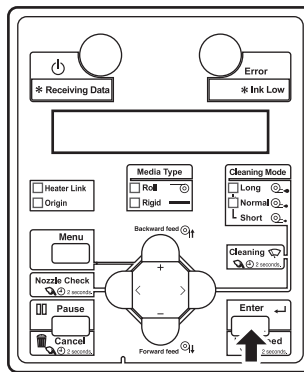

- A confirmation pattern will be printed.  
Four confirmation patterns of A to F will be printed.

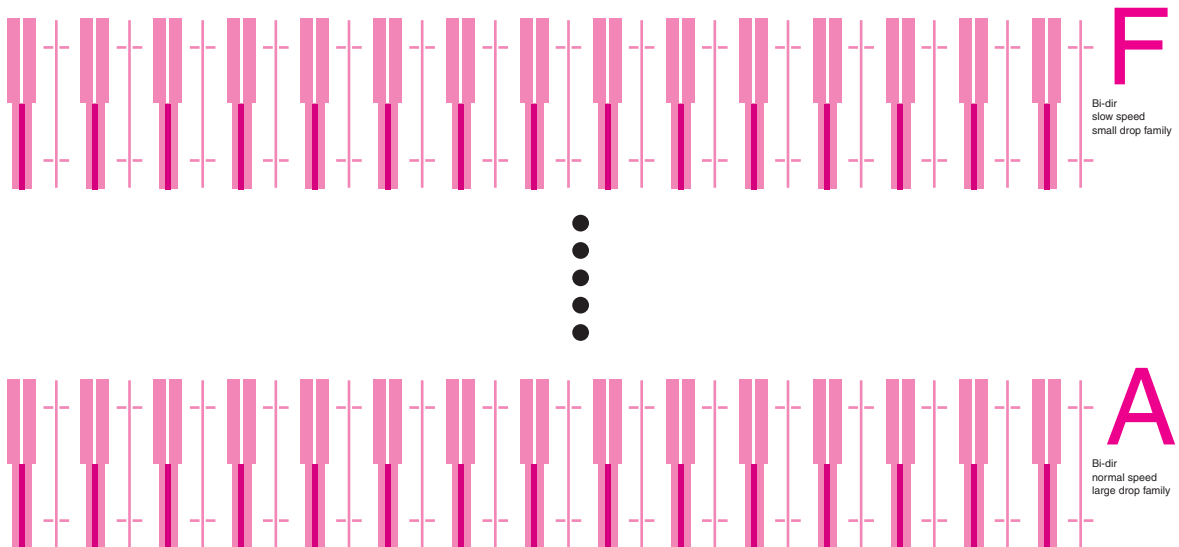

- After the confirmation pattern is printed, Operation panel returns to “Adj.1: Confirm”.

4. Confirm that the confirmation pattern print result is as follows.

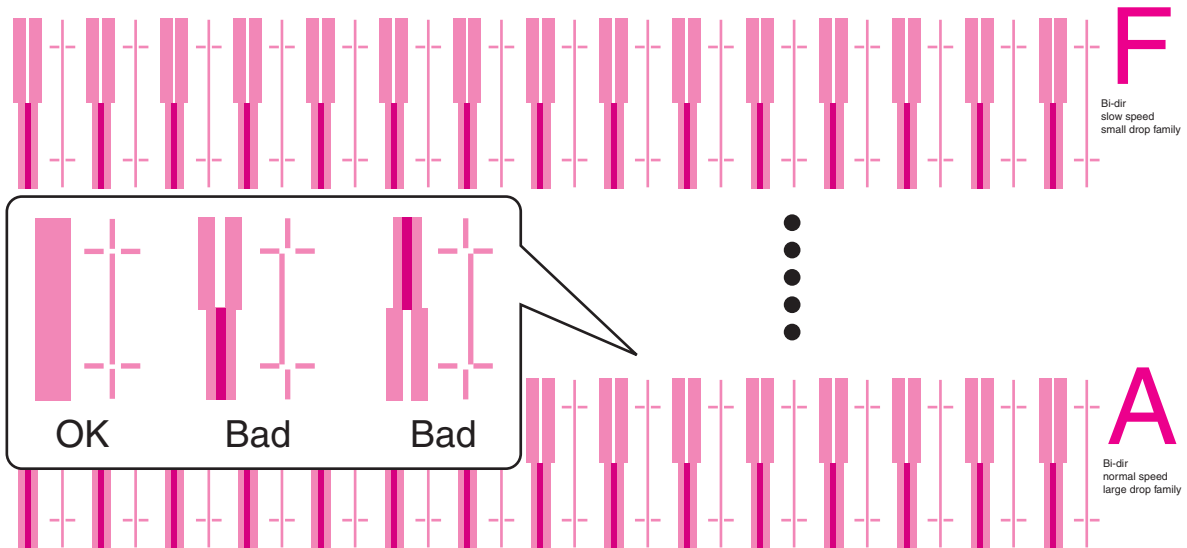

- Check each of the confirmation patterns A to F.



- When the print result is “OK”;  
You do not need perform print quality adjustment.  
The procedure for print quality adjustment is complete.
- When the print result is “Bad”;  
You need to perform print quality adjustment.
  - Perform rough adjustment when the degree of misalignment is large.  
🔗 [3.7.2.2 Custom rough adjustment pattern](#)
  - Perform fine adjustment when the degree of misalignment is small.  
When adjustment is required for all patterns (A to F):  
🔗 [3.7.2.3.1 Fine Ptn. ALL](#)  
When adjustment is required for one of the patterns (A to F):  
🔗 [3.7.2.3.2 Fine Pattern A to F](#)

### 3.7.2.2 Custom rough adjustment pattern

Perform rough adjustment when the degree of misalignment is large.  
Print rough adjustment pattern and register the set values.

Menu name		Description	Reference
Adj. Print2 : Custom	Rough Ptn. ALL	All confirmation patterns (A to F) will be adjusted.	 <a href="#">3.7.2.2.1 Rough Ptn. ALL</a>
	Rough Pattern A to F	One of the confirmation patterns (A to F) will be adjusted.	 <a href="#">3.7.2.2.2 Rough Pattern A to F</a>

#### 3.7.2.2.1 Rough Ptn. ALL

1. Display the Custom Adjust Print menu in the same way as Step 2 of [3.7.2.1 Custom confirmation pattern](#).
2. Press the [+] key or [-] key to select “Adj.2: Rough Pattern”.

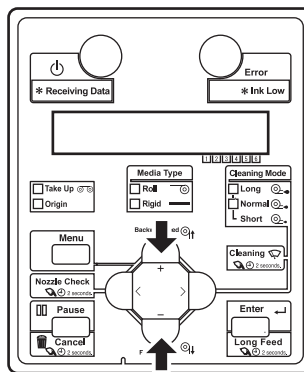

3. Press the [Enter] key.

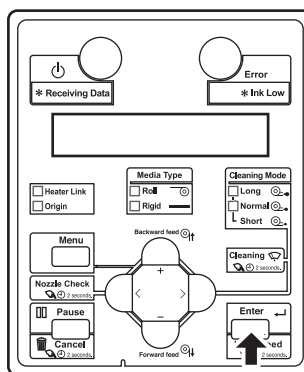



- A rough adjustment pattern will be printed.

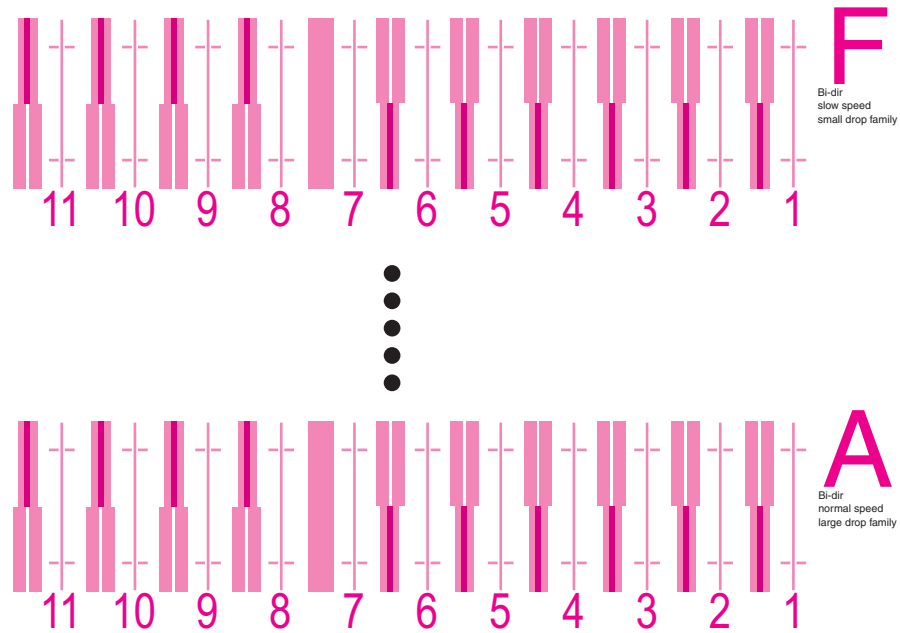

- For the rough adjustment pattern, the same patterns will be printed on both sides and center of the media.
- Nine rough adjustment patterns (A to F) are printed.
- “PatternA: 6” is displayed.

4. Check the print results on both sides and center of the media and select the number that looks most aligned between 1 and 11.
- “7” is selected in the following pattern A.

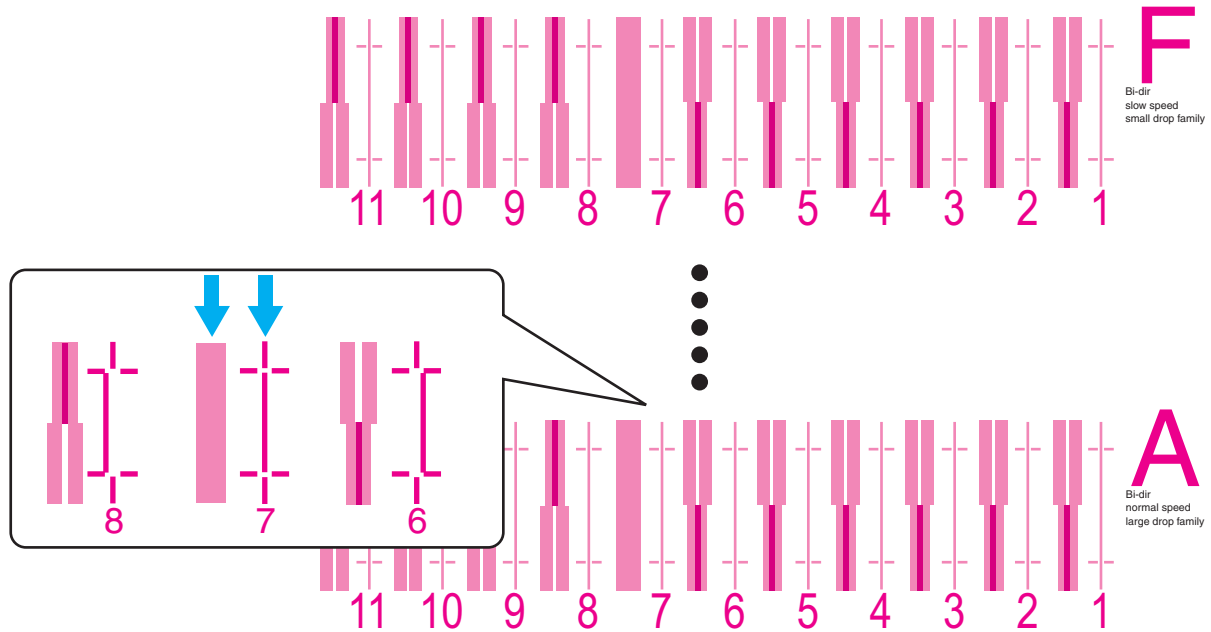
**NOTE**

“6” represents the current setting value.

5. Press the [+] key or [-] key to enter the number that you selected in Step 4.

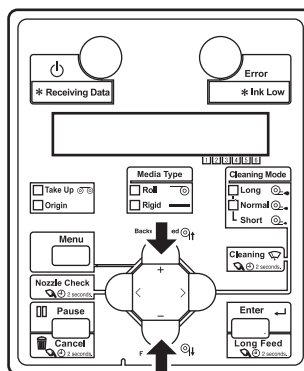
**NOTE**

When you press the [Cancel] key on Operation panel, the setting value is not entered and the display returns to “Adj.2: Rough Pattern”.

6. Press the [Enter] key.

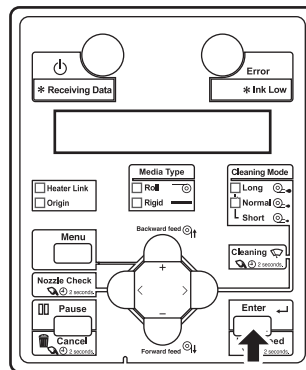

- Determines the setting.
7. Enter the values for patterns B to F in the same way.
- Press the [Enter] key to set the value.
  - Once all set values have been entered, press the [Enter] key to register the set values of patterns A to F.
  - “Adj.2: Rough Pattern” is displayed.

## 3.7.2.2.2 Rough Pattern A to F

Print one rough adjustment pattern from A to F and register the set value.  
The following describes how to adjust pattern A only.

1. Display the Custom Adjust Print menu in the same way as Step 2 of [3.7.2.1 Custom confirmation pattern](#)
2. Press the [+] key or [-] key to select “Adj.3: Rough Pattern A”.

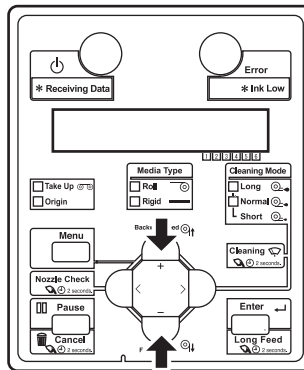

3. Press the [Enter] key.

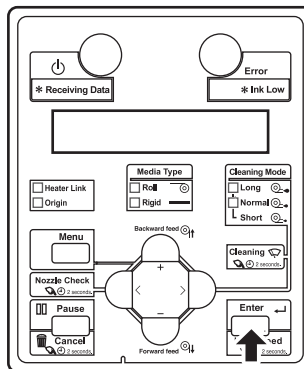

- A rough adjustment pattern will be printed.

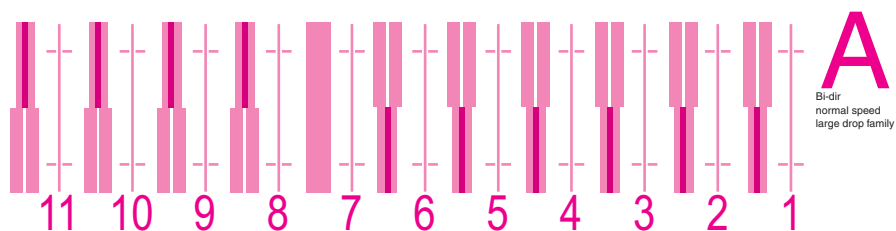

- For the Adjust print pattern, the same patterns will be printed repeatedly on both sides and center of the media.
- “PatternA: 6” is displayed.

- Check the print results on both sides and center of the media and select the number that looks most aligned between 1 and 11.

- “7” is selected in the following pattern A.

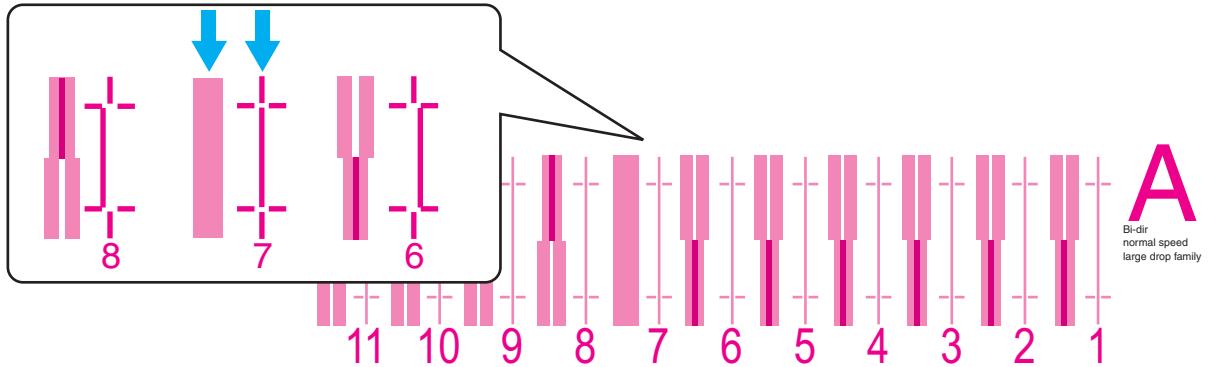

### NOTE

“6” represents the current setting value.

- Press the [+] key or [-] key to enter the number that you selected in Step 4.

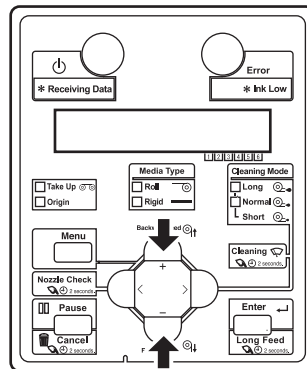

### NOTE

When you press the [Cancel] key on Operation panel, the setting value is not entered and the display returns to “Adj.3: Rough Pattern A”.

6. Press the [Enter] key.

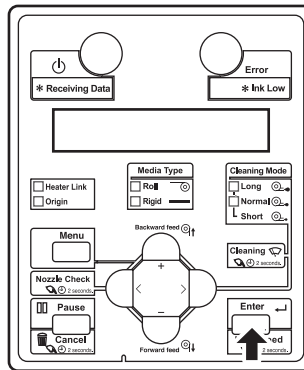

- Determines the setting.
- “Adj.3: Rough Pattern A” is displayed.

### 3.7.2.3 Custom fine adjustment pattern

Perform fine adjustment when the degree of misalignment is small.  
This menu consists of the following menus.

Menu name	Description	Reference
Adj. Print2 : Custom	Fine Ptn. ALL	All confirmation patterns (A to F) will be adjusted.
	Fine Pattern A to F	One of the confirmation patterns (A to F) will be adjusted.

#### 3.7.2.3.1 Fine Ptn. ALL

Print fine adjustment pattern ALL and register the set values.

1. Display the Custom Adjust Print menu in the same way as Step 2 of 3.7.2.1 Custom confirmation pattern
2. Press the [+] key or [-] key to select “Adj.9: PatternALL”.

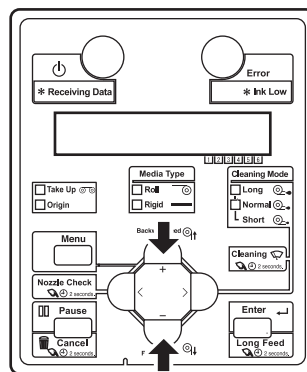

3. Press the [Enter] key.

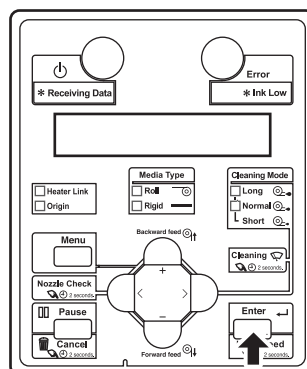

- A fine adjustment pattern will be printed.  
For Adjust print pattern printing, nine adjust print patterns (A to F) are printed.

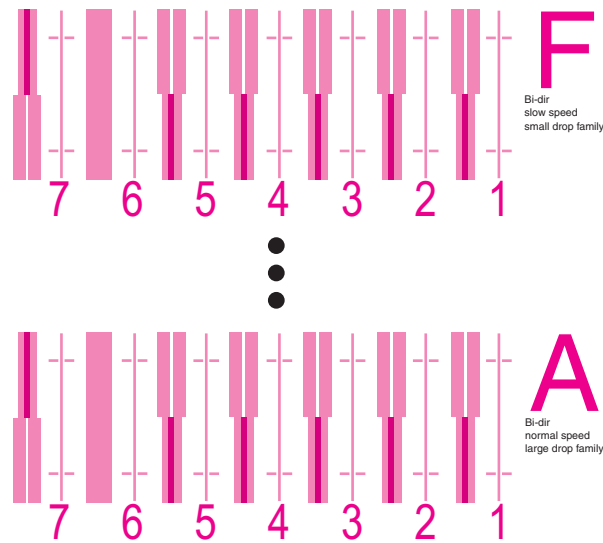

- For the Adjust print pattern, the same patterns will be printed repeatedly on both sides and center of the media.
4. Check the print results on both sides and center of the media and select the number that looks most aligned between 1 and 7.
- “6” is selected in the following pattern A.

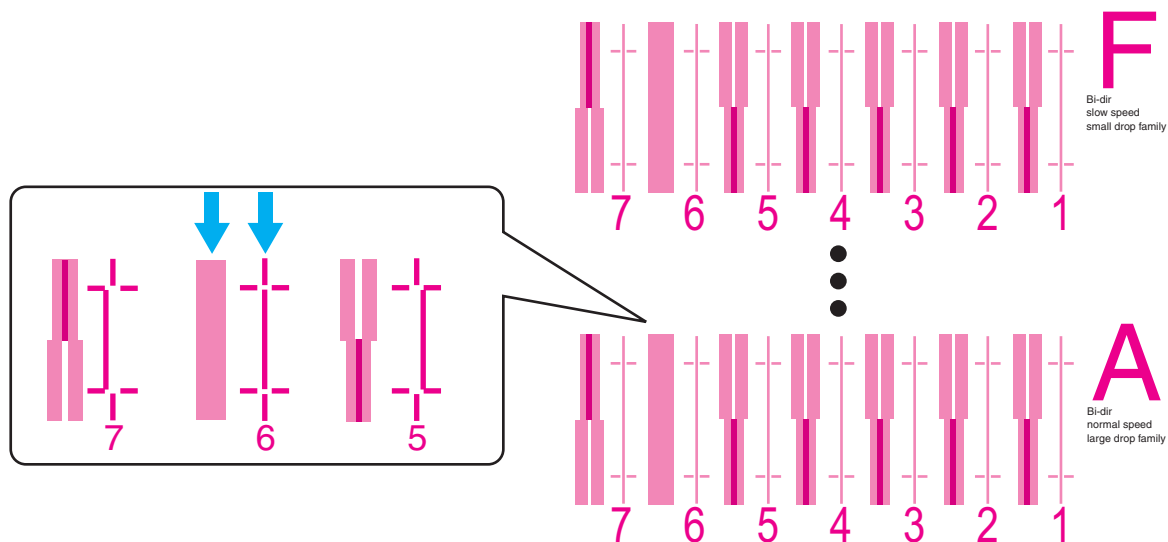
**NOTE**

“4” represents the current setting value.

5. “Pattern\*1: 4” is displayed.



6. Press the [+] key or [-] key to enter the number that you selected in Step 4.

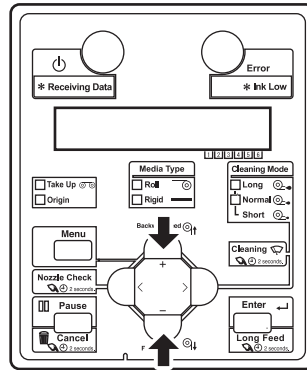

### NOTE

When you press the [Cancel] key on Operation panel, the display returns to “Adj.9: Adj. PatternALL”.

7. Press the [Enter] key.

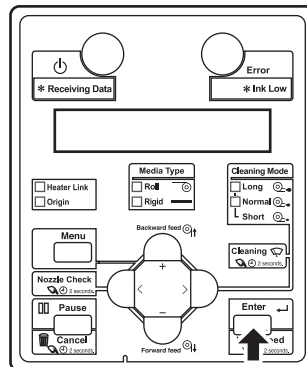

- Determines the setting.
8. Enter the values for patterns B to F in the same way.
- Press the [Enter] key to set the value.
  - Once all set values have been entered, press the [Enter] key to register the set values of patterns A to F.
  - “Adj.9: Adj. PatternALL” is displayed.

### 3.7.2.3.2 Fine Pattern A to F

Print one fine adjustment pattern from A to F and register the set value.  
The following describes how to adjust pattern A only.

1. Display the Custom Adjust Print menu in the same way as Step 2 of [3.7.2.1 Custom confirmation pattern](#).
2. Press the [+] key or [-] key to select “Adj10: Adj. PatternA”.

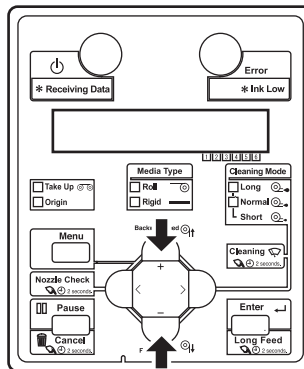

3. Press the [Enter] key.

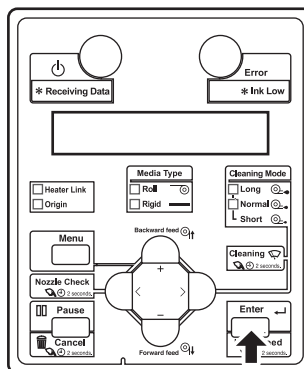

- A fine adjustment pattern will be printed.

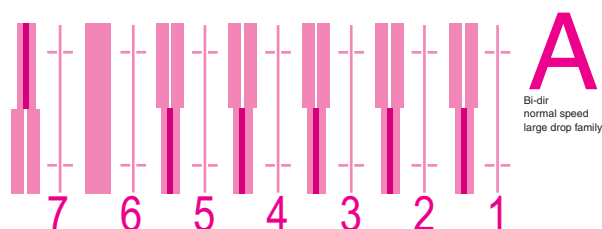

- For the Adjust print pattern, the same patterns will be printed repeatedly on both sides and center of the media.

4. Check the print results on both sides and center of the media and select the number that looks most aligned between 1 and 7.
  - “6” is selected in the next printing sample.

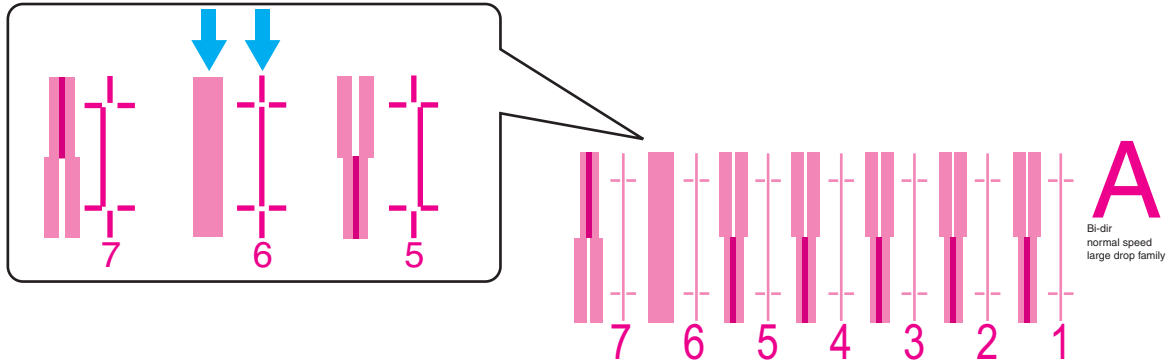
**NOTE**

“4” represents the current setting value.

5. “PatternA: 4” is displayed.
6. Press the [+] key or [-] key to enter the number that you selected in Step 4.

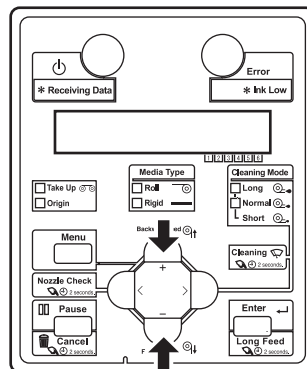
**NOTE**

When you press the [Cancel] key on Operation panel, the display returns to “Adj10: Adj. PatternA”.

7. Press the [Enter] key.

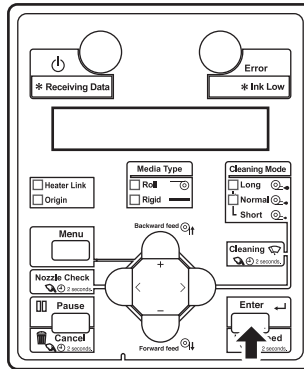

- Determines the setting.
- “Adj10: Adj. PatternA” is displayed.

## 3.8 Connecting the printer to PC

This section explains how to connect the printer and a PC.

### 3.8.1 System requirements

The operating systems with which this printer is compatible are as follows.

Operating system	Windows 8, Windows 7, Windows Vista
------------------	-------------------------------------

#### NOTE

- The required memory varies depending on the application software or the print data type.
- A large hard disk and memory are recommended.
- For the system requirements for the operation of the software server RIP (option), refer to the operation manual of the software server RIP.

### 3.8.2 Preparing cables

The printer is equipped with a network interface for connecting with a PC. You need a network interface cable to connect a PC with this printer. Prepare the cable depending on the PC that it will be connected to.

#### TIP

- About connecting a network interface cable, refer to “[3.8.3 Connecting a network interface cable](#)”.
- For the recommended cable specifications, refer to “[8.2 Interface specification](#)”.

### 3.8.3 Connecting a network interface cable

This section explains how to connect a network interface cable.

Follow the procedure below to connect this printer to your PC.

1. Turn OFF both the printer and PC.
2. Insert the connector of the network interface cable into the network interface connector located in the back of the printer.

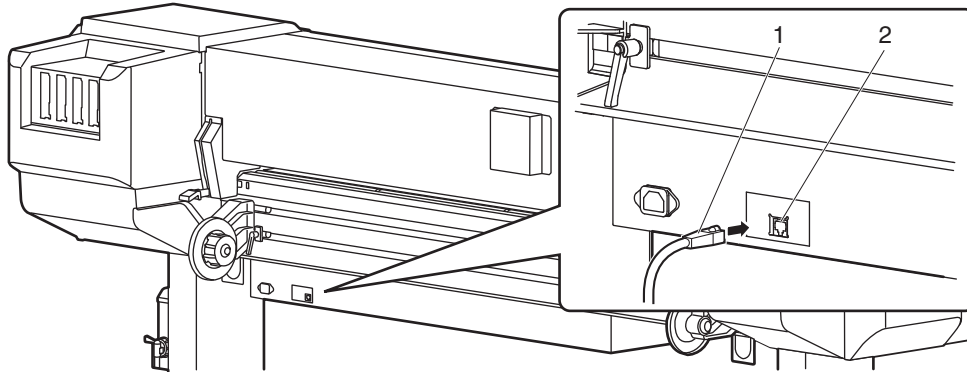

No.	Name
1	Network interface cable
2	Network interface cable connector

3. Connect the other connector of the network interface cable to your PC.

**TIP**

About connecting to your PC, refer to the operation manual included with the PC.

### 3.8.4 Setting the IP address

This section explains how to set the IP address of the printer side.

Follow the procedure below to set the IP address.

1. Confirm that the printer is turned ON.  
     ☞ [3.2.1 Turning the power ON](#)
2. Press the [Menu] key.

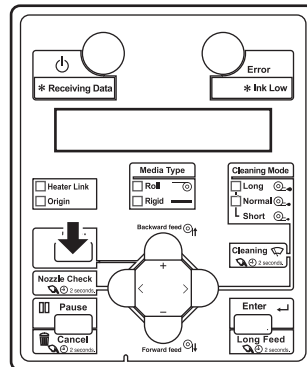

- “Menu 1: Sleep Mode>” is displayed.
3. Use the [+] or [-] key to select “Menu 9: Initial>”.
  4. Press the [>] key.

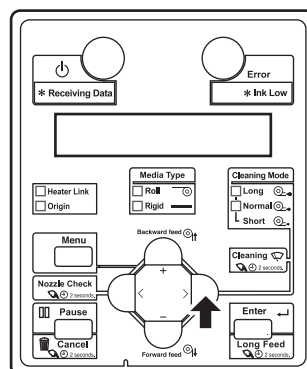

- “Initial1: Language” is displayed.

5. Press the [+] key or [-] key to select “Initial3: IP Address”.

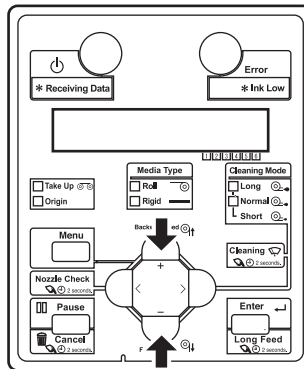

6. Press the [Enter] key.

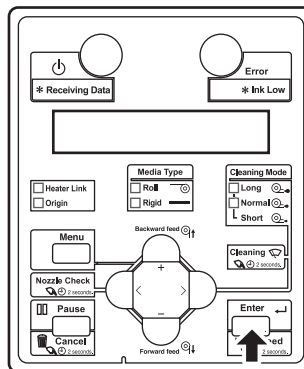

- “192.168.1.253” (default) is displayed.

7. Press the following keys and set the value.

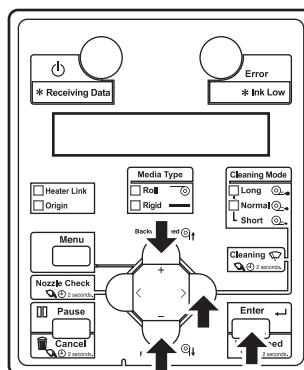

- [+] key: increases the setting value.
- [-] key: decreases the setting value.
- [Enter] key and [>] key: change the setting for the next segment.



- After setting is completed, press the [Cancel] key.

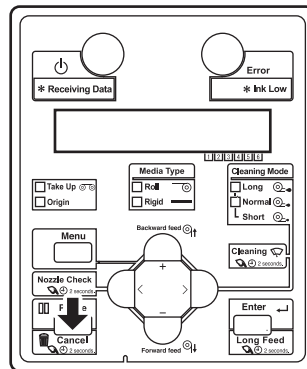

- The display enters the previous menu.
- Reboot the printer.

**NOTE**

After setting the IP address, be sure to reboot the printer.  
When the printer is not rebooted after setting the IP address, the setting value may return to the default.

### 3.8.5 Setting subnet mask

This section explains how to set the subnet mask of the printer side.

Both the printer and the network connecting the printer must have the same subnet mask setting.

Configure the subnet mask following the procedure below.

1. Confirm that the printer is turned ON.

 [3.2.1 Turning the power ON](#)

2. Press the [Menu] key.

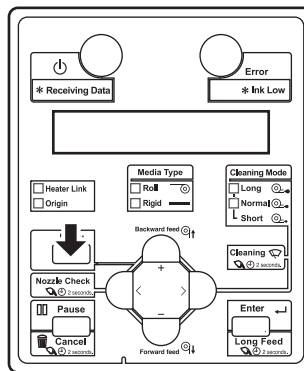

- “Menu 1: Sleep Mode>” is displayed.

3. Press the [+] key or [-] key to select “Menu 9: Initial>”.

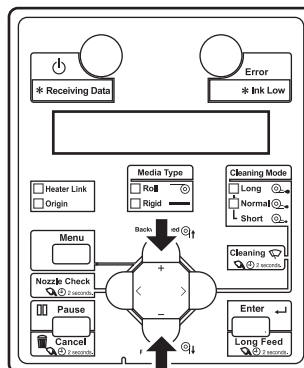

4. Press the [>] key.

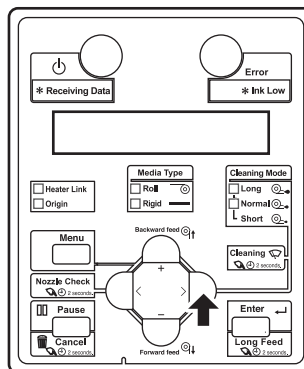

- “Initial1: Language” is displayed.

5. Press the [+] key or [-] key to select “Initial4: Subnet Mask”.

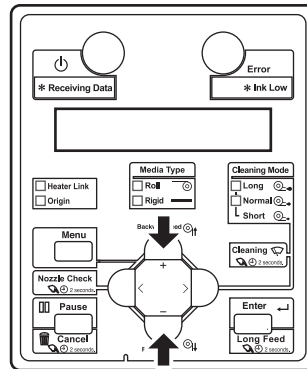

6. Press the [Enter] key.

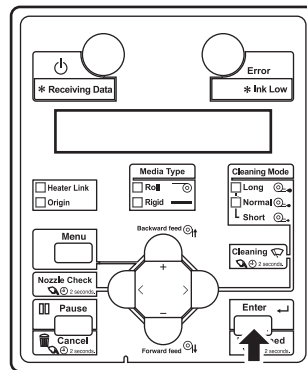

- “255.255.255.0” (default) is displayed.

7. Press the following keys and set the value.

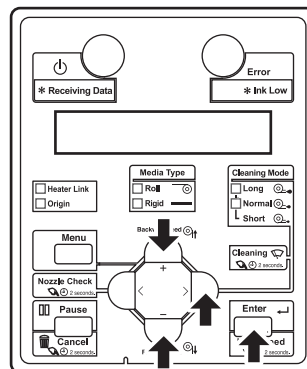

- [+] key: increases the setting value.
- [-] key: decreases the setting value.
- [Enter] key and [>] key: change the setting for the next segment.

8. After setting is completed, press the [Cancel] key.

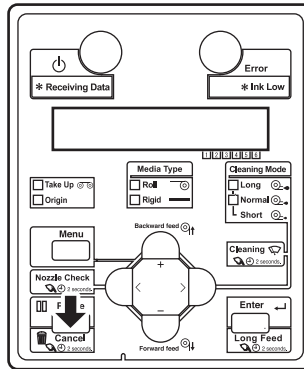

- The display enters the previous menu.

9. Reboot the printer.

#### NOTE

After setting the subnet mask, be sure to reboot the printer.  
When the printer is not rebooted after setting the IP address, the setting value may return to the default.

### 3.8.6 Gateway setting

This section explains how to set the gateway on the printer side.

Both the printer and the gateway connecting the printer must have the same setting.

Follow the procedure below to set the gateway.

1. Confirm that the printer is turned ON.

 [3.2.1 Turning the power ON](#)

2. Press the [Menu] key.

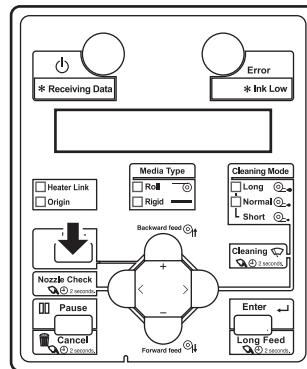

- “Menu 1: Sleep Mode>” is displayed.

3. Press the [+] key or [-] key to select “Menu 9: Initial>”.

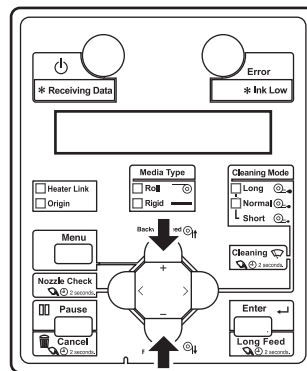

4. Press the [>] key.

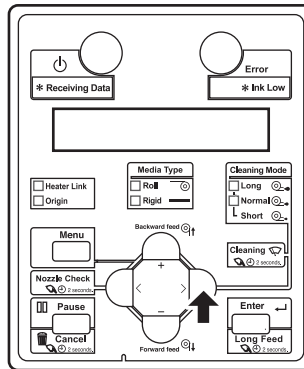

- “Initial1: Language” is displayed.

5. Press the [+] key or [-] key to to select “Initial5: Gateway”.

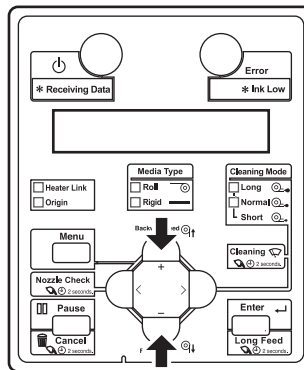

6. Press the [Enter] key.

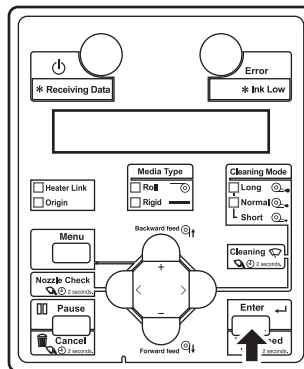

- “192.168.1.254” (default) is displayed.

7. Press the following keys and set the value.

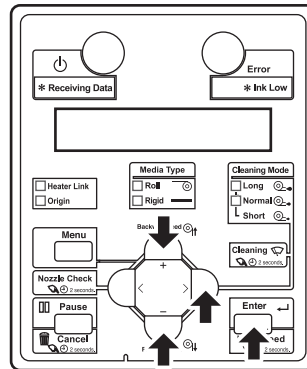

- [+] key: increases the setting value.
- [-] key: decreases the setting value.
- [Enter] key and [>] key: change the setting for the next segment.

8. After setting is completed, press the [Cancel] key.

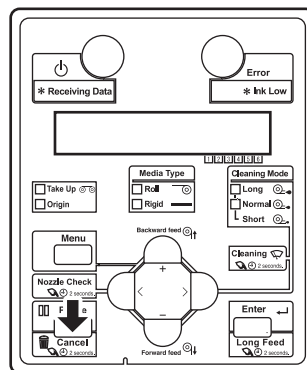

- The display enters the previous menu.

9. Reboot the printer.

#### NOTE

After setting the gateway, be sure to reboot the printer.

When the printer is not rebooted after setting the IP address, the setting value may return to the default.





## 4 Handling the printer

This chapter explains how to handle the printer.

## 4.1 Print flow chart

The following flow chart illustrates the procedure to perform printing with the printer. Refer to each section as required.

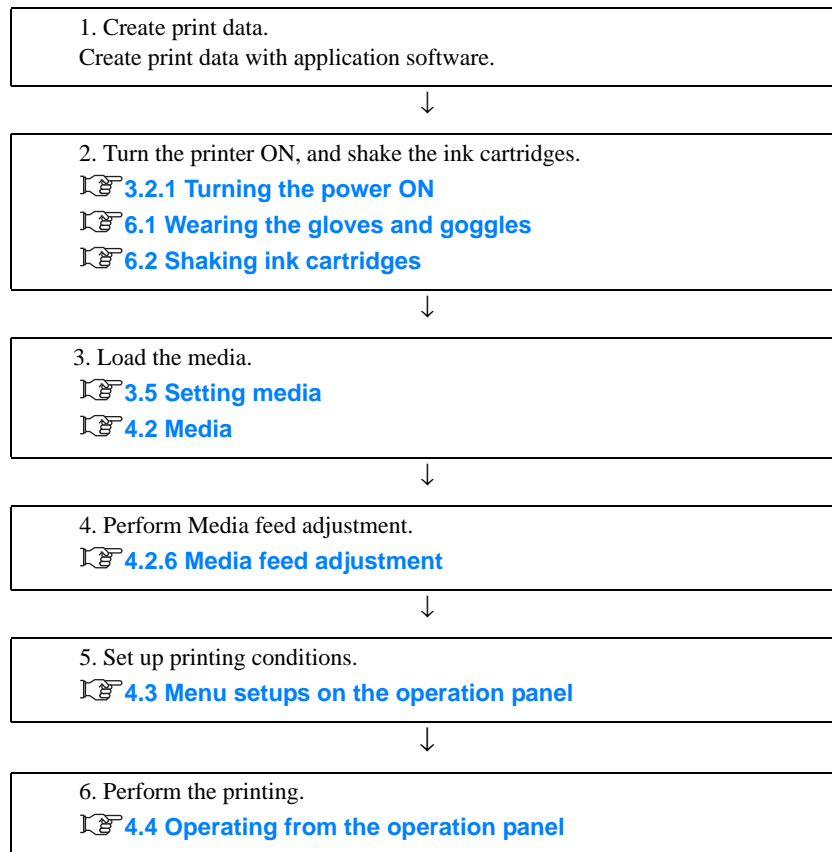

**CAUTION**

- Before performing work, make sure to read the safety data sheet (SDS).
- Ventilate the workplace. When using the printer in a poorly-ventilated location, install a ventilation device. Otherwise the ink odor may damage your health.
- Do not touch UV curable ink with bare hands prior to ink curing. Skin or eye contact with UV curable ink may cause skin inflammation or allergic reaction.
  - Wear protective gloves, goggles and/or face shield, and clothing while using of the printer.
  - If glove becomes contaminated with ink, replace it with new.
  - If protective clothing becomes contaminated with ink, immediately remove and wash for re-use.
  - If ink gets on skin, immediately wash with soap and plenty of water for 15 minutes. Seek medical advice/attention if irritation or inflammation are present.
- The bluish white light that comes from the UV-LED equipment is ultraviolet light. Ultraviolet light may leak a little from the gaps of the equipment. The level of this ultraviolet light that leaks from the equipment is minimized, but be alert of the following points when handling this product.
  - Do not look at the ultraviolet light at close range for a long period of time. This may cause eye damage.
  - Do not shine the ultraviolet light on your skin at close range for a long period of time. This may cause skin inflammation.

**NOTE**

- Do not open the front cover during printing. If the front cover is opened, printing will be interrupted. Printing restarts if you close the front cover. However, you are not guaranteed to have high print quality.
- When in standby or after completing printing, be sure to close the front cover and maintenance cover. The ink may slowly be cured even from indoor light, causing malfunctions such as ink clogs, maintenance unit mechanical failures, and head damage. Modifying or disassembling this product completely voids the Warranty.
- Do not use this product with the cover open or if it has been modified.

## 4.2 Media

This section explains details of available media for this printer.

### 4.2.1 Loadable media

#### <Rigid media>

You can load the following rigid media \*1 on this printer:

- Maximum width: 1,625 mm
- Minimum width: 182 mm
- Maximum depth: 1,200 mm
- Minimum depth: 200 mm
- Thickness: 15 mm or less (including media warpage and unevenness)
- Weight: 15 kg or less
- Media warpage: Less than 1 mm (when the media thickness is uneven, make sure that the total of the warpage and unevenness is less than 1 mm. Also, do not print with the warpage facing up).

\*1: Hard media such as a board is described as “rigid media” in this manual.

#### <Roll media>

You can load the following roll media on this printer:

- 2 inch / 3 inch tube roll media
- Diameter: 150 mm or less
- Maximum width: 1,625 mm
- Minimum width: 182 mm
- Weight: 30 kg or less
- Make sure that the media does not warp on the platen due to curls.

## 4.2.2 Cautions on handling media

Note the following points when handling the media.

### NOTE

- Use media under an appropriate environment.  
The appropriate temperature and humidity for printing are as follows.

	Temperature	Humidity
Guaranteed range of printing accuracy	22°C to 30°C	40% to 60%
Change rate	Within $\pm 2^\circ\text{C}$ per hour	Within $\pm 5\%$ per hour

- Do not use media which is folded, cut, or torn.
- The size of media can change according to changes in humidity in the printing environment. Before using media, leave media for 30 minutes in the printing environment to adapt it to the environment.  
Performing printing without adapting media to the printing environment may cause media jams due to gaps or wrinkles in the media.  
Print quality is also affected.
- Do not touch the print side.  
Moisture and oil on your hands may affect the print quality.
- Do not leave media set in the printer for a long time.  
Some media has a tendency to bend, causing media jams and degradation of print quality.  
Avoid using such media especially in winter and in dry conditions.
- Do not discard the individual box and bag. Use them for storing media.

## 4.2.3 Precaution on storing media

Note the following points on storing media.

### NOTE

- Avoid high temperature, high humidity, and direct sunlight when storing media.
- After removing the unused roll media from the roll media holder, wind it properly. Then wrap it with an individual bag and store it in an individual box.
- Keep the media dry.

## 4.2.4 Printing area

The printable area of this printer is as follows.

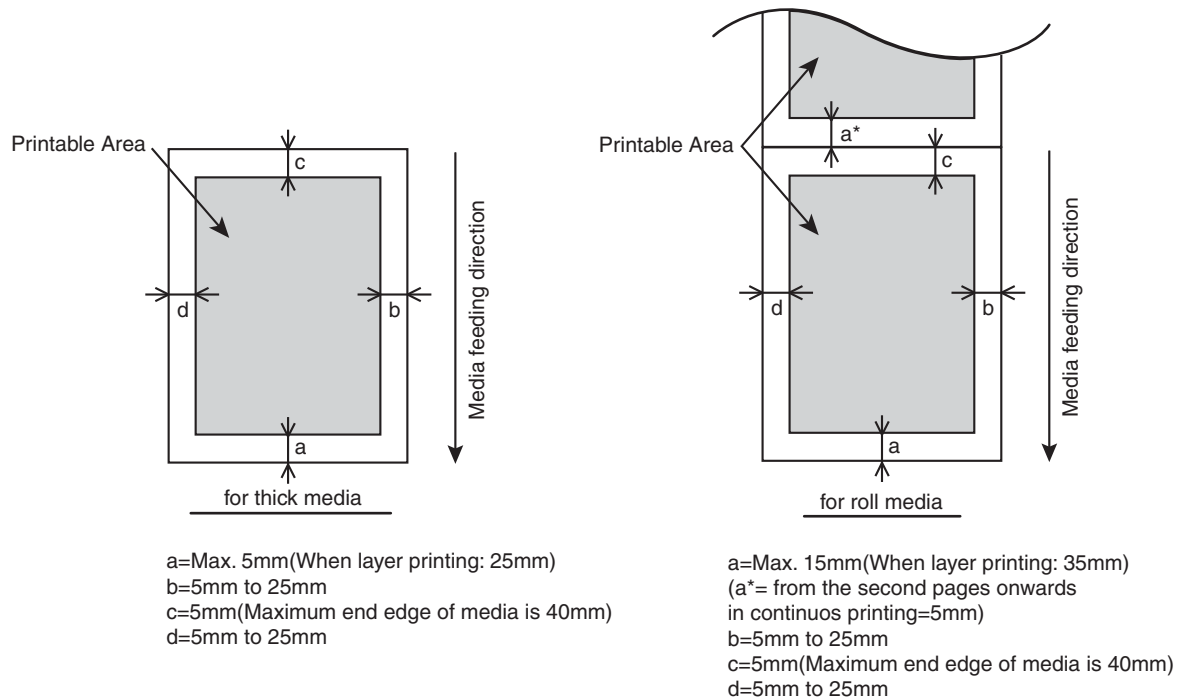

## 4.2.5 Head height adjustment

Printing with high printing rate or using strongly-curved media can cause print heads to rub. Adjusting the distance from the print head surface to media (head height) may allow you to avoid head rub.

Follow the procedure below to adjust the head height.

### NOTE

If the head height is raised, high print quality is not guaranteed.

1. Display the Media Thickness Adjust menu.
  - a. Press the [Menu] key.
    - “Menu1: Sleep Mode>” is displayed.
  - b. Press the [>] key.
    - “Menu2: User Type>” is displayed.

- c. Press the [>] key.
  - “Media: Type 1” is displayed.
- d. Press the [+] key or [-] key to select the media type to use.
  - Selected User type (Type 1 to 30) is displayed.
- e. Press the [Enter] key.
  - “\*\*>1: Print Mode” is displayed.

**TIP**

- The selected media (Type 1 to 30) is displayed in “\*\*\*”.  
🔗 [5.2 User Type menu](#)
- If you set the User type different from the previous time when the Media detection is set to On, “Change Media Thickness?” is displayed.
  - Press the [Enter] key to overwrite the detected media thickness with the User type you have set here.
  - Press the [Cancel] key to return to the selection screen of User type.

- f. Press the [+] key or [-] key to select “\*\*>6: Thickness Adj.”.
  - g. Press the [Enter] key.
    - “Adjust: \*.\* mm” is displayed.
2. Press the [+] key or [-] key to change the setting value for the head height.

**NOTE**

The setting value range you can change is up to 1.5 mm plus the standard media thickness.

3. Press the [Enter] key.
  - The value set is saved.
  - “\*\*>6: Thickness Adj.” is displayed.
  - Head height correction is complete.

## 4.2.6 Media feed adjustment

This section explains the Media feed adjustment.

The feeding length depends on the media type. The following or similar results may be seen in prints.

- Printed images overlap.
- White lines are printed on images.

Accuracy of media feeding may be improved by adjusting the media correction value in some cases.

When you have changed the media, perform media feeding correction.

Follow the procedure below to perform media feeding correction.

1. Display the Media feed adjustment menu.
  - a. Press the [Menu] key.
    - “Menu1: Sleep Mode>” is displayed.
  - b. Press the [+] or [-] key to select “Menu2: User Type>”.
  - c. Press the [>] key.
    - “User: Type1” is displayed.
  - d. Press the [+] key or [-] key to select the user type to use.
    - Selected User type (Type 1 to 30) is displayed.
  - e. Press the [Enter] key.
    - “\*\*>1: Print Mode” is displayed.

### TIP

- The selected media (Type 1 to 30) is displayed in “\*\*”.
-  [5.2 User Type menu](#)
- If you set the User type different from the previous time when the Media detection is set to On, “Change Media Thickness?” is displayed.
    - Press the [Enter] key to overwrite the detected media thickness with the User type you have set here.
    - Press the [Cancel] key to return to the selection screen of User type.

- f. Press the [+] key or [-] key to select “\*\*>3: PF Adjust>”.
- g. Press the [>] key.
  - “PF1: Initial Print” is displayed.



## 2. Performs initial adjust print.

- a. Press the [Enter] key.
  - “Feed Length: 250 mm” is displayed.

**TIP**

- The length of media that is fed (feeding length) for initial adjustment printing is normally set at 250 mm.
- If you increase the feeding length, the accuracy of the Media feed adjustment improves.  
To change the feeding length, press the [+] key or [-] key and change the set value.

## b. Press the [Enter] key.

- “Printing” is displayed.
- Starts Initial adjustment printing.



No.	Name
1	Feed Length
2	Media feeding direction

- When the initial adjustment printing is complete, the printer enters Normal.

## c. After the initial adjustment printing, cut the media.

 [4.4.3 Cutting media](#)

## 3. Measure the distance between the two pluses (+) in the initial adjustment print using a ruler.

## 4. Sets up Initial Adjust Change.

- a. Press the [+] key or [-] key to select “PF2: Initial Change”.
- b. Press the [Enter] key.
  - “Init.: 250.0/250 mm” is displayed.
- c. Press the [+] key or [-] key and enter the measured value in step 3.

- d. Press the [Enter] key.
  - The initial adjustment value is saved.
  - “PF2: Initial Change” is displayed.

5. Performs Confirm Print.

- a. Press the [+] key or [-] key to select “PF3: Confirm Print”.
- b. Press the [Enter] key.
  - “Feed Length: 250 mm” is displayed.

**TIP**

- The length of media that is fed (feeding length) for confirmation adjustment printing is normally set at 250 mm.
- If you increase the feeding length, the accuracy of the Media feed adjustment improves. To change the feeding length, press the [+] key or [-] key and change the set value.

- c. Press the [Enter] key.
  - “Printing” is displayed.
  - Starts Confirmation adjustment printing.



No.	Name
1	Feed Length
2	Media feeding direction

- When the Confirm Print is complete, the printer enters Normal.
- d. After the confirmation adjustment printing, cut the media.
    - 🔗 [4.4.3 Cutting media](#)

6. Measure the distance between the two pluses in the confirmation adjustment print using a ruler. Then, confirm that the distance matches the feeding length when printing.
  - a. If the distance does not match the feeding length, follow the procedure from Step 1 to Step 5 and readjust.
  - b. If the distance matches the feeding length, proceed to step 7.
7. Performs Micro adjustment print.
  - a. Display the Media feed adjustment menu in the same way as in step 1.
  - b. Press the [+] key or [-] key to select “PF4:Micro Print”.
  - c. Press the [Enter] key.
    - “Printing” is displayed.
    - Starts Micro adjustment printing.

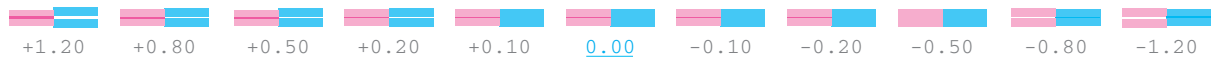

- With a focus on the micro adjustment value that is currently set, micro adjustment patterns are printed by adding the following adjustment value.
  - Added correction value:  $\pm 0.10\%$ ,  $\pm 0.20\%$ ,  $\pm 0.50\%$ ,  $\pm 0.80\%$ ,  $\pm 1.20\%$
  - After the micro adjustment printing is completed, “PF4:Micro Print” is displayed.
8. Refer to the illustrations below and check the printing result.
    - The Micro adjustment value has the least white lines or overlapping images.
    - Use the number on the bottom right of the print result as the Micro adjustment value.

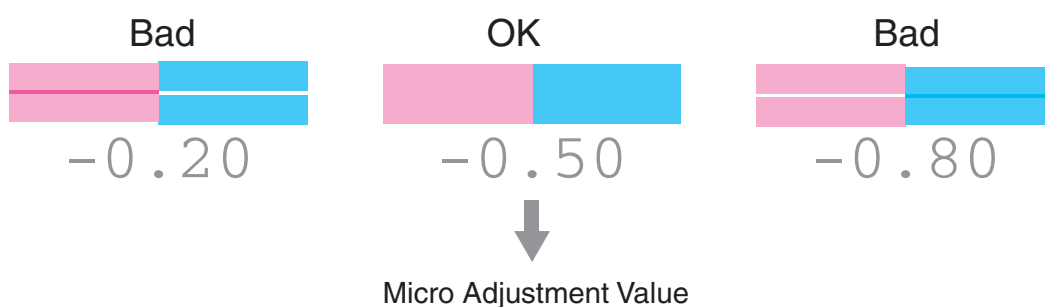

9. Sets up Micro Adjustment Change.
  - a. Press the [+] key or [-] key and enter the micro adjustment value according to the print result in Step 8.
  - b. Press the [Enter] key.
    - The micro adjustment value is saved.
    - “PF4:Micro Print” is displayed.
10. Press the [Menu] key.
  - The operation panel returns to Normal.
  - The adjustment of media feed adjustment value is complete.

## 4.2.7 Installing media holder plates

When you use thin media (with a thickness of less than 0.5 mm) such as roll media, warpage may occur on both edges of the media depending on the media type or use conditions, resulting in damage to the media by the print head surface.

To prevent this, use the media holder plates to reduce the amount of curling in the media.

Follow the procedure below to install the media holder plates.

1. Display the Side margin menu.
  - a. Press the [Menu] key.
    - “Menu1: Sleep Mode>” is displayed.
  - b. Press the [+] or [-] key to select “Menu3: Setup>”.
  - c. Press the [>] key.
    - “Set1: Side Margin” is displayed.
  - d. Press the [Enter] key.
    - “Side Margin: \*\* mm” is displayed.
    - The display shifts to the Side Margin menu.  
[🔗 5.3.1 Side Margin menu](#)

### NOTE

The current setting value is displayed in the “\*\*” of the Side Margin menu.

2. Set up the margins (side margins) to more than 6 mm during printing.
  - a. Press the [+] key or [-] key to set the side margins to more than 6 mm.
  - b. Press the [Enter] key.
    - After having saved the setting, “Set1: Side Margin” is displayed.
  - c. Press the [Cancel] key several times.
    - The operation panel returns to Normal.
3. Used to load the roll media.  
[🔗 3.5.5 Setting roll media](#)

4. Set the media holder plates by sliding them from both sides of the platen.

**NOTE**

Do not use the media holder plates for media whose thickness is 500  $\mu\text{m}$  (0.5 mm) or thicker. The media holder plate may interfere with the print head.

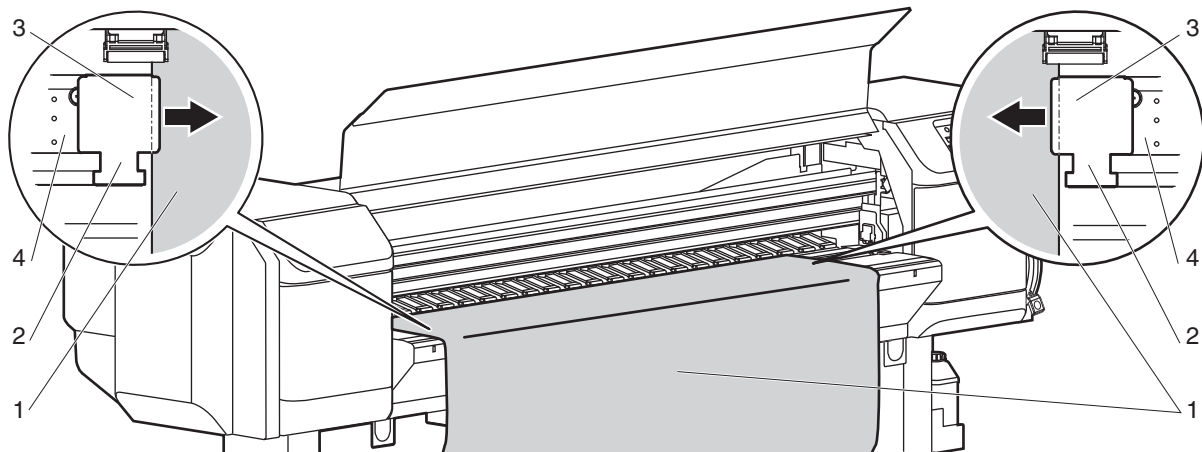

No.	Name
1	Roll media
2	Media holder plate
3	Media loading position
4	Platen

5. After installing the media holder plates, make sure that they do not interfere with the media as it is fed through the printer.

**CAUTION**

- If a media jams when using the media holder plates, the plates may be deformed. When the media holder plates are deformed,
  - Do not remove the clogged media by force.
  - Stop using the printer.
- Using the printer with deformed media plates may damage the grid roller or print heads. Contact your local MUTOH dealer.

**NOTE**

If there is interference with the media as it is fed through the printer after the media holder plates have been installed, the media holder plates should not be used.

6. If the plates are not used, return the plates to their initial positions as shown in the following figure.

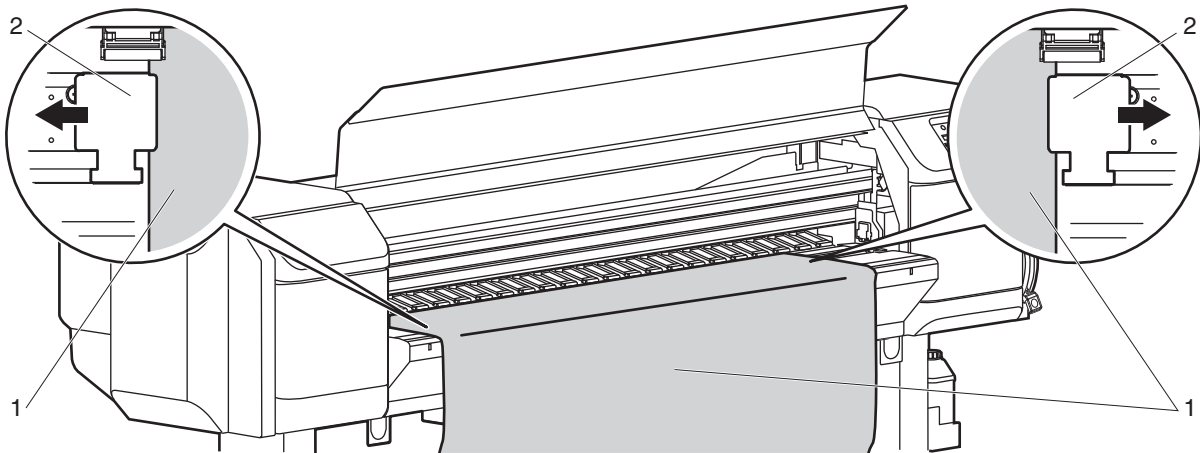

No.	Name
1	Roll media
2	Media holder plate

## 4.3 Menu setups on the operation panel

### 4.3.1 Panel setup menu overview

This sub-section explains the Panel setup menu of the printer.  
There are the following items in the Panel setup menu.

Setup item	Description
Sleep Mode menu	Sleep mode settings are configured.
User Type menu	Media is configured.
Setup menu	Various settings of the printer are configured.
Test Print menu	Performs nozzle check of the print head and setup list.
Cleaning menu	Perform Head cleaning.
Menu option menu	Set up the contents of the Setup menu.
Maintenance menu	Print head cleaning using cleaning fluid or maintenance operation before long storage is performed.
Version menu	Displays the versions of the firmware.
Initial menu	Display language or unit for LCD is configured. IP addresses are also configured.
Job status menu	Displays information about the previous printing result.

**TIP**

For details of each setup item, refer to “[5 Panel setup menu](#)”.



### 4.3.2 Menu setup procedure

Follow the procedure below to configure each setup menu.

1. Confirm that the operation panel is Normal.
2. Press the [Menu] key.

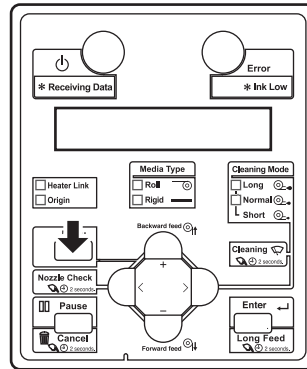

- “Menu1: Sleep Mode>” is displayed.

3. Press the [+] key or [-] key to select a setup item and press the [Enter] key.

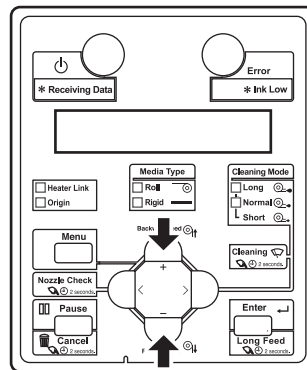

4. Press the [>] key.

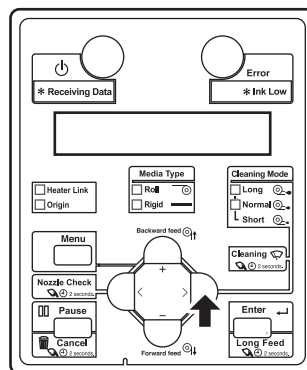

- Shifts to the selected setting menu.

5. When there are multiple setting items, press the [+] or [-] key to select the item.
6. Press the [Enter] key.

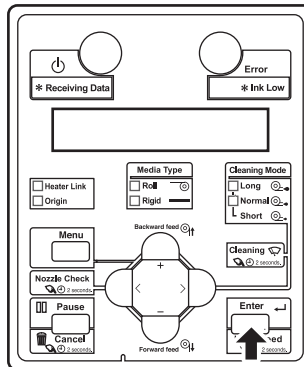

- Confirm the setting items to be changed.
- When setup items have a submenu, the display shifts to the next menu.

#### NOTE

- When a setup item has a submenu, “>” is displayed on the right end of the LCD monitor of Operation panel.
- For the general outline of each setup item, refer to “[4.3.1 Panel setup menu overview](#)”.

7. The setting in the blinking part on the LCD monitor can be changed. Press the [+] key or [-] key to change the setting.

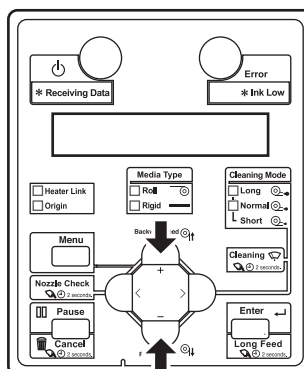

8. To save the changed setting, press the [Enter] key.

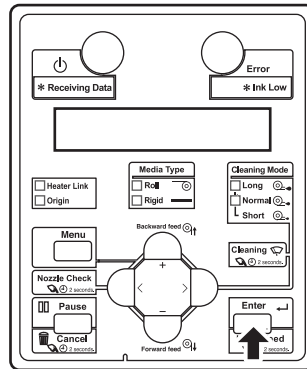

- The setting is saved and the next setup item is displayed.

### NOTE

If you press the [Cancel] key, [+] key or [-] key without pressing [Enter] key after changing a setting, the change will not be saved.

9. Press the [Cancel] key to exit from the setup.

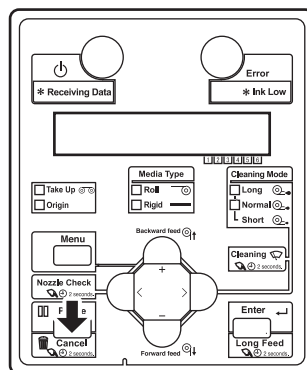

- The previous setup menu is displayed.
- When the main menu is displayed, the screen turns to Normal.

## 4.4 Operating from the operation panel

This section explains various functions that can be operated from the operation panel.

### TIP

For names and functions of each key, refer to "2.2.3 Operation panel".

### 4.4.1 Feeding media

You can feed roll media at a position that you want.

Follow the procedure below to feed media.

1. Confirm that the operation panel is Normal.
2. Make sure that Front media loading lever is lowered (Rear media loading lever is raised).
3. Press the [Forward↓] key or the [Backward↑] key.

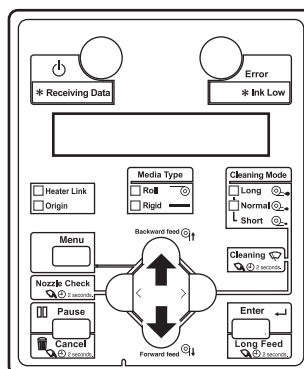

- Media is fed forward or backward.
4. Release the [Backward↑] key or [Forward↓] key after feeding media to the desired position.

## 4.4.2 Stopping printing operation

If you want to stop printing for some reason, operate as follows.

1. Stop sending printing data from the computer to the printer.
2. Press the [Cancel] key.

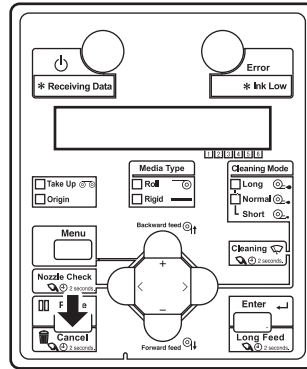

- The printer operates as follows.

Printer status	Operation with the [Cancel] key pressed more than 2 seconds
During printing	Terminates the printing, and deletes one data remaining in the printer.
Receiving Data/Analyzing Data	Deletes the received/analyzed data and the subsequent data.

### NOTE

If a large amount of data is saved on the printer, the operation panel may not return to Normal by a single [Cancel] key operation.

In such cases, wait for a few seconds and press the [Cancel] key again.

### 4.4.3 Cutting media

This sub-section explains how to cut roll media.

Follow the procedure below to cut roll media.

1. Verify the following regarding the operational condition of the product.
  - Printing or other operations are not in progress.
  - The operation panel display is Normal.
2. To change the position to cut the roll media, refer to “[4.4.1 Feeding media](#)” and advance the roll media to the desired cut position.
3. Open the front cover.

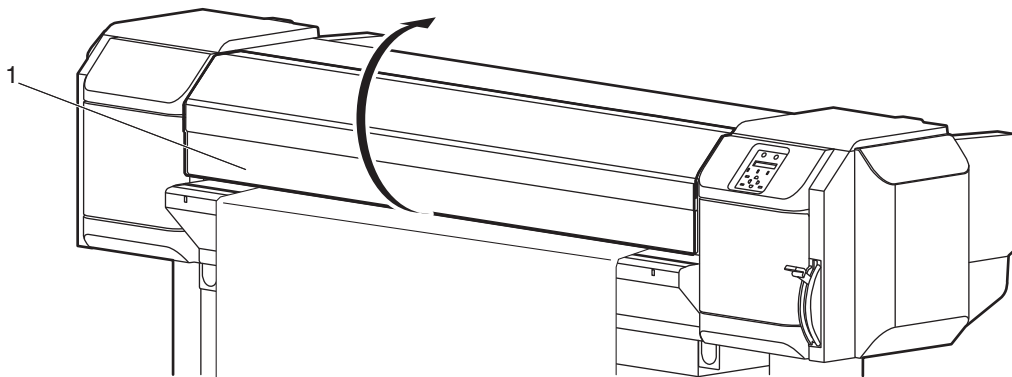

No.	Name
1	Front cover

4. Place a razor blade on the media cut groove on the media guide, and cut the roll media.

**CAUTION**

- Pay attention to the following points when you cut roll media.  
Mishandling the razor blade may cause a cut on your finger or hand.
- When you hold media, do not place your finger on the media cut groove.
- Move the razor blade along the media cut groove.

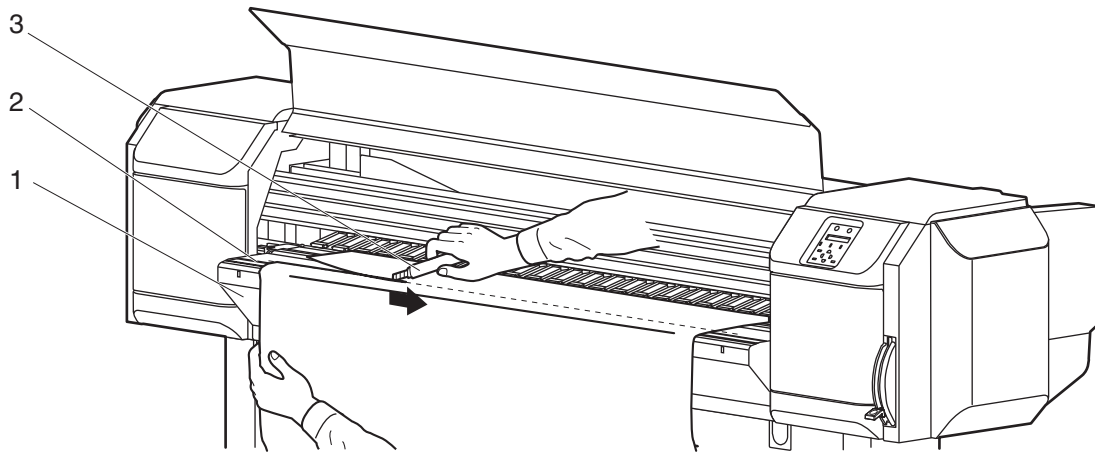

No.	Name
1	Media guide
2	Media cut groove
3	Razor blade

- Cutting roll media is complete.

**NOTE**

When loading the new roll media, cut the front edge of the media if it is not straight.

## 4.4.4 Changing and confirming settings while printing

While the printer is operating, you can change or confirm settings for the Panel setup menu.

### 4.4.4.1 Procedure for changing and confirming settings while printing

Follow the procedure below to change or confirm settings for the Panel setup menu.

1. Confirm that the printer is in one of the following conditions.
  - Receiving Data
  - Analyzing Data
  - Printing Data
2. Press the [Menu] key.

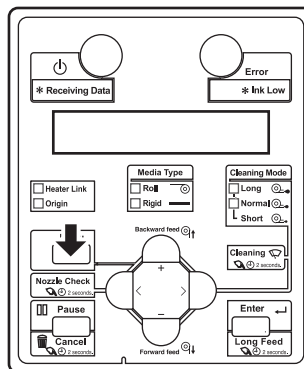

- “Menu 1: Sleep Mode>” is displayed.
3. Press the [+] key or [-] key to change or confirm settings.

#### NOTE

For the setting items whose settings can be changed or confirmed, refer to “[4.4.4.2 Settings that can be changed or confirmed while printing](#)”.



#### 4.4.4.2 Settings that can be changed or confirmed while printing

##### NOTE

- When you change a setting during operation, be sure to select “Backup” to save the setting that you changed.  
If the printer returns to Normal without “Backup” being selected, the changed setting is not saved.
- Check the following before using the Job status items
  - The values displayed in the Job status items are rough indications.  
They do not guarantee the strict accuracy.
  - If the length information is not included in the print data, “0” is displayed for all items.
  - You can check the “Remain” and “Remain Time” in the way described in [☞ 4.4.6 Normal Display while Printing](#).
  - To check the information about the printed data, refer to the following.  
[☞ 5.10 Job Status Menu](#)

Setup item	Setting	Description
PF Adjust	-5.00% to 0.00% to 5.00%	Change the feed adjustment value.
Backup	-	<ul style="list-style-type: none"> <li>• [Enter] key: Save the changed setting.</li> </ul>
Job Status	ToDoLength	<ul style="list-style-type: none"> <li>• Check the whole length of the data (media feed direction) currently being printed.</li> </ul>
	Done	<ul style="list-style-type: none"> <li>• Check the printed length of the data currently being printed.</li> </ul>
	Remain	<ul style="list-style-type: none"> <li>• For the data currently being printed, check the length of the data that has not been printed.</li> </ul>
	Remain Time	<ul style="list-style-type: none"> <li>• Displays the time remaining for printing.</li> </ul>
—	—	<ul style="list-style-type: none"> <li>• [Cancel] key: The printer returns to Normal.</li> </ul>

### 4.4.5 Pausing printing

It is possible to pause to print during printing.

Follow the procedure below to pause or restart printing.

#### NOTE

If the printing is paused, the print quality will not be guaranteed.

1. Check that the printer is in operating.
2. Press the [Pause] key.

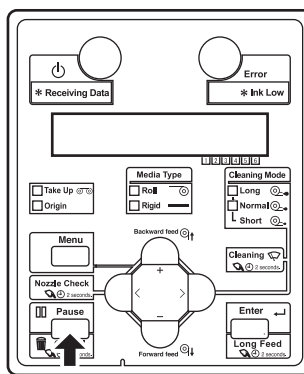

- The printer pauses printing.
  - “PrintRestart -> ENTER” is displayed.
3. To restart printing, press the [Enter] key.

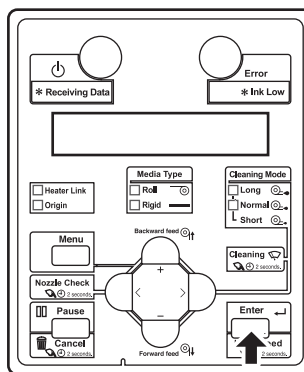

- The printer restarts printing.

## 4.4.6 Normal Display while Printing

The remaining length and remaining time to complete the currently printing data can be displayed by an easy operation.

### NOTE

- The values displayed in this function are just standard values, not guarantee the accuracy.
- If the print data includes no length data, all information will be displayed as “0”.
- To check more detailed information of currently printing data, please refer to the below.  
[☞ 4.4.6 Normal Display while Printing](#)
- To check the information of printed data, please refer to the below.  
[☞ 5.10 Job Status Menu](#)

Follow the procedures below to display the information.

1. Check if the printer is printing a data.
2. Press the [-] key to display “Print Remain”.

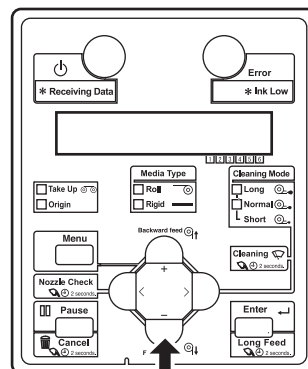

- The remaining length of data currently printing will be displayed.

P r i n t   R e m a i n   x x x . x m

### TIP

- When the length display setting is set to inch, the length will be displayed in inch.  
[☞ 5.9.2 Length menu](#)
- The [+] key also can switch the display. In that case, “Remain Time” (Step 3) will be displayed first.

3. Press the [-] key to display “Remain Time”.

- The remaining length of data currently printing will be displayed.

R e m a i n T i m e    x x x x m i n

4. Press the [-] key to display “Roll Remain”.

- The remaining length of roll media will be displayed.

R o l l R e m a i n    x x x m

**NOTE**

The remaining roll media is displayed when the [5.3.9 Roll Length menu](#) is set to other than OFF.

5. To return the display to “Printing”, press the [-] key.

P r i n t i n g

## 5 Panel setup menu

The section explains the Setup menu of the printer.

Setup item	Description
Sleep mode menu	Sleep mode settings are configured. ☞ 5.1 Sleep mode menu
User Type menu	Media is configured. ☞ 5.2 User Type menu
Setup menu	Various settings of the printer are configured. ☞ 5.3 Setup menu
Test Print menu	Performs nozzle check of the print head and setup list. ☞ 5.4 TestPrint Menu
Cleaning menu	Perform Head cleaning. ☞ 5.5 Cleaning menu
Menu option menu	Sets up the contents of the Setup menu. ☞ 5.6 Menu Option menu
Maintenance menu	Print head cleaning using cleaning fluid or maintenance operation before long storage is performed. ☞ 5.7 Maintenance menu
Version menu	Displays the versions of the firmware. ☞ 5.8 Version menu
Initial menu	Display language or unit for LCD is configured. IP addresses are also configured. ☞ 5.9 Initial menu
Job status menu	Displays information about the previous printing result. ☞ 5.10 Job Status Menu

### TIP

- The <> parts in each list are factory default settings (default).
- For details of the Setup menu, refer to the following manual.

☞ 9 Setup menu diagram

## 5.1 Sleep mode menu

Sleep mode settings are configured.

When you activate sleep mode, the printer operates as follows.

For detailed operation, check “[3.3.1 Set sleep mode on the printer](#)”.



### WARNING

- **Use the printer with its power turned permanently on. When you are not using the printer, always leave the power on and put the printer into the sleep mode. If you do not put the printer into the sleep mode, the ink in its interior could settle out and/or coagulate, causing poor image quality or printer failure.**

Setup item	Setting	Description
Sleep Mode	Set Timer	Set the auto cleaning interval of this printer for Sleep Mode. <a href="#">☞ 5.1.1 Timer Setting menu</a>
	Type	Select the cleaning mode while in sleep mode. <a href="#">☞ 5.1.2 Cleaning Type menu</a>
	Start	Activate Sleep Mode <a href="#">☞ 5.1.3 Sleep Mode Start menu</a>
	—	<ul style="list-style-type: none"> <li>• [Cancel] key: shifts to the previous menu. <a href="#">☞ 5.3 Setup menu</a></li> </ul>

### 5.1.1 Timer Setting menu

Set the Head cleaning interval of this printer for Sleep Mode.

When more than the set time has passed, the print head is cleaned automatically.

#### NOTE

- During Sleep Mode, even if the set amount of time has passed, print-head cleaning is not performed under the following circumstances.
  - Front cover or Maintenance cover is open.
  - The waste fluid tank is full.
  - There is little remaining ink in the ink cartridge (or no ink).
  - The ink cartridge has been removed.
  - The inserted ink cartridge is not the genuine ink cartridge, etc.

When the printer returns to a normal state, Head cleaning is restarted, and Sleep Mode continues.

 [7.2 Error messages](#)

- If one of the above conditions occurs during Head cleaning, cleaning is stopped. When the printer returns to a normal state, Head cleaning is restarted.

 [7.2 Error messages](#)

Setup item	Setting	Description
Set Timer	<Off>	• Off:
	1/2/3/4/5/6/9/12/18/24 hours	• When the set time has elapsed, the Head cleaning starts.
	—	• [Cancel] key: shifts to the previous menu.  <a href="#">5.1 Sleep mode menu</a>

### 5.1.2 Cleaning Type menu

Select the cleaning type while in sleep mode.

Setup item	Setting	Description
Type	<Short>	• Short: Discharges smaller amount of ink compared to Normal.
	Normal	• Normal: Select this mode normally.
	Long	• Long: Discharges a larger amount of ink compare to Normal. Use this when Normal Head cleaning cannot improve the problem of the Print head.
	—	• [Cancel] key: shifts to the previous menu.  <a href="#">5.1 Sleep mode menu</a>

### 5.1.3 Sleep Mode Start menu

Activate Sleep Mode.

- During Sleep Mode, “Restart -> Enter” will be displayed in the operation panel.  
During Sleep Mode, pressing [Enter] key will return the printer to normal operation.

#### NOTE

- If the printer is under one of the following conditions while shifting to the Sleep Mode, “Don’t Start Sleep Mode” is displayed, and will not shift to the Sleep Mode.
  - Front cover or Maintenance cover is open.
  - The waste fluid tank is full.
  - There is little remaining ink in the ink cartridge (or no ink).
  - The ink cartridge has been removed.
  - The inserted ink cartridge is not the genuine ink cartridge, etc.

Activate Sleep Mode again after returning the printer to a normal state.

 [7.2 Error messages](#)

- If the printer is under one of the conditions above during the Sleep mode, the printer will not return to the Normal condition even pressing the [Enter] key.  
Return the printer to a normal state, and press [Enter] key to return the printer to normal operation.

 [7.2 Error messages](#)

Setup item	Setting	Description
Start	—	<ul style="list-style-type: none"> <li>• [Enter] key: Activate Sleep Mode.  <a href="#">3.3.1 Set sleep mode on the printer</a></li> </ul>



## 5.2 User Type menu

### 5.2.1 Type menu

Sets the user type setting for printing.

You can set up to 30 different user settings as “Type 1 to 30” depending on the media type.

Setup item	Setting	Description
User	Type 1	Settings for the media type to print are configured. It is possible to set 30 different user settings as “Type 1 to 30” for printing. • [Enter] key: shifts to the sub menu. <a href="#">☞ 5.2.2 Various settings of User type</a>
	Type 2	
	...	
	Type 29	
	Type 30	
	—	• [Cancel] key: cancels the setting and shifts to the previous menu.

#### NOTE

If you set the User type different from the previous time when the Media detection is set to On, “Change Media Thickness?” is displayed.

- Press the [Enter] key to overwrite the detected media thickness with the User type you have set here.
- Press the [Cancel] key to return to the selection screen of User type.

[☞ 3.5.7.1 When the media thickness detection is ON](#)

#### CAUTION

- **When the media detection is set not to detect the media thickness (When the media detection is set to any of “Off”, “Top & Width” or “Width”), and the media type is changed, “Warning! \*.\*mm” is displayed.**
- **Check if the value matches the thickness of the loaded media. If the value is wrong, enter the correct setting value.**
- **If a wrong value is set, the head and media collide and may damage the head. If you set a value smaller than the actual media thickness, the media may touch and break Print head.**

[☞ 3.5.7.2 When the media thickness detection is OFF](#)

## 5.2.2 Various settings of User type

Various settings on the user media settings are configured.

In User media menu, 30 different settings can be set as Type 1 to 30 for the following printing operation.







### NOTE







If media other than recommended one is used, the following problems may occur.

- Media detection error
- Slant, torn and wrinkle of media
- Media jams
- Favorable print quality cannot be obtained due to blots, blurs or dirt of ink.
- End detection of roll media cannot be performed, etc.

The problems caused by the use of user media will not be covered by the warranty and repair expenses will be paid by the customer.

For details, contact your local MUTOH dealer.

Setup item	Setting	Description
Type 1 to 30	Print Mode	Sets up the print mode according to the usage of print data or print speed. <ul style="list-style-type: none"> <li>• [Enter] key: shifts to the sub menu.</li> </ul>  <a href="#">5.2.2.1 Print mode menu</a>
	Adjust Print	Sets up when adjusting the printer for the optimum quality of image print. <ul style="list-style-type: none"> <li>• [ &gt; ] key: shifts to the sub menu.</li> </ul>  <a href="#">5.2.2.3 PF Adjust menu</a>
	PF Adjust	Sets up various settings on the Media feed adjustment. <ul style="list-style-type: none"> <li>• [ &gt; ] key: shifts to the sub menu.</li> </ul>  <a href="#">5.2.2.3 PF Adjust menu</a>
	Vacuum Fan	Sets up vacuum fan operation. <ul style="list-style-type: none"> <li>• [Enter] key: shifts to the sub menu.</li> </ul>  <a href="#">5.2.2.4 Vacuum Fan menu</a>
	Media thickness	<ul style="list-style-type: none"> <li>• If the media thickness detection at media initialization is set to OFF, enter the media thickness.</li> <li>• Displays the detected media thickness if media thickness detection is performed during media initialization.</li> <li>• [Enter] key: shifts to the sub menu.</li> </ul>  <a href="#">5.2.2.5 Media thickness menu</a>
	Thickness Adj.	Adjusts the media thickness. <ul style="list-style-type: none"> <li>• [Enter] key: shifts to the sub menu.</li> </ul>  <a href="#">5.2.2.6 Thickness Adjust menu</a>
	Media Initial	Sets whether or not to detect the media thickness, width, and edge during media initialization. <ul style="list-style-type: none"> <li>• [ &gt; ] key: shifts to the sub menu.</li> </ul>  <a href="#">5.2.2.7 Media Initial menu</a>

Setup item	Setting	Description
Type 1 to 30	Media Width (width check)	<ul style="list-style-type: none"> <li>If the media width detection at media initialization is set to OFF, enter the media width between the loading mark and the left end of the media.</li> <li>Displays the detected media width if media detection is performed during media initialization.</li> <li>[Enter] key: shifts to the sub menu.</li> </ul>  <a href="#">5.2.2.8 Media Width/Width check menu</a>
	Strike wait time	Sets up the waiting time while overwrite printing. <ul style="list-style-type: none"> <li>[Enter] key: shifts to the sub menu.</li> </ul>  <a href="#">5.2.2.9 Strike Wait menu</a>
	Rigid/Roll	Set which of roll media or rigid media will be used. <ul style="list-style-type: none"> <li>[Enter] key: shifts to the sub menu.</li> </ul>  <a href="#">5.2.2.10 Rigid/Roll menu</a>
	Show Edges	The LED pointer indicates the printing area and its corners before printing. <ul style="list-style-type: none"> <li>[Enter] key: shifts to the sub menu.</li> </ul>  <a href="#">5.2.2.11 Show Edges menu</a>
	Initialization	Initializes the settings. <ul style="list-style-type: none"> <li>[Enter] key: shifts to the sub menu.</li> </ul>  <a href="#">5.2.2.12 Initialization menu</a>
	Add Y Layer (available in 6-color configuration)	Print the yellow layer underneath of the white layer of White-underlay or Three-layer print data. <ul style="list-style-type: none"> <li>[Enter] key: shifts to the sub menu.</li> </ul>  <a href="#">5.2.2.13 Add Y Layer (available in 6-color configuration)</a>
	—	<ul style="list-style-type: none"> <li>[Cancel] key: shifts to the previous menu.</li> </ul>  <a href="#">5 Panel setup menu</a>



### 5.2.2.1 Print mode menu

Settings for print quality (print mode) are set according to the usage of print data or print speed.

#### NOTE

When “Banner 1” is set in the Print Mode menu, “PalettePrint” is not displayed in the Test Print menu.

 [5.4 TestPrint Menu](#)

Setup item	Setting	Description
Mode	Quality 1	Sets up print mode.
	Quality 2	<ul style="list-style-type: none"> <li>Quality 1 to 2: Sets up to perform high quality printing.</li> </ul>
	Graphics 1	<ul style="list-style-type: none"> <li>Graphics 1 to 2: Sets up to perform standard printing.</li> </ul>
	<Graphics 2>	<ul style="list-style-type: none"> <li>Banner 1 to 2: Sets up to perform high speed printing.</li> </ul>
	Banner 1	<ul style="list-style-type: none"> <li>Displays details of each print mode while pressing [&gt;] key.</li> </ul>
	Banner 2	<ul style="list-style-type: none"> <li>Displays details of each print mode while pressing [&gt;] key.</li> </ul> <p> <a href="#">Details of print mode</a></p>
	—	<ul style="list-style-type: none"> <li>[Enter] key: saves the setting and shifts to the previous menu.</li> <li>[Cancel] key: cancels the setting and shifts to the previous menu.</li> </ul> <p> <a href="#">5.2 User Type menu</a></p>

### Details of print mode

The settings for print quality registered in each print mode are as follows.

Print Mode	Resolution	Pass		Direction
		Using 4 Colors	Using 5 Colors	
Quality 1	1440×1440 dpi	16 times	32 times	Uni (unidirectional)
Quality 2	1440×1440 dpi	16 times	32 times	Bi (bidirectional)
Graphics 1	720×1440 dpi	8 times	16 times	Uni (unidirectional)
Graphics 2	720×1440 dpi	8 times	16 times	Bi (bidirectional)
Banner 1	720×1080 dpi	6 times	12 times	Bi (bidirectional)
Banner 2	720×720 dpi	4 times	8 times	Bi (bidirectional)

### 5.2.2.1.1 Effect menu

Sets up the Effect menu.

Set up this menu when you want to improve print quality by adjusting the set print mode.

#### NOTE

The print quality may not be improved depending on the printing condition.

Setup item	Setting	Description
Effect	None	The Effect function is not used.
	<i>Weave UV>	The printing joint will shade off.
	—	<ul style="list-style-type: none"> <li>• [Enter] key: saves the setting and shifts to the previous menu.</li> <li>• [Cancel] key: cancels the setting and shifts to the previous menu.</li> </ul> <a href="#">☞ 5.3 Setup menu</a>

### 5.2.2.2 Adjust Print menu

Sets up when adjusting the printer for the optimum quality of image print.

#### NOTE

- This printer was adjusted at the factory shipment so that it obtains the optimum printing quality. Adjust the quality if the print quality changes after the installation environment or the media is changed.
- When newly setting or changing the user type setting after adjusting Standard adjust print, make sure to adjust print.
- Since all print modes are adjusted at once after performing Custom adjust print, adjust print is not required even after changing the print mode.
- When specifying a print mode which is different from the mode set in the user type setting, adjust all print modes in the Custom adjust print first.

Setup item	Setting	Description
Adjust Print	Standard	Adjusts only the print mode in the user type setting which is currently set. ☞ 3.7.1 Standard print quality adjustment
	Custom	Perform adjustment for all print modes. ☞ 3.7.2 Custom print quality adjustment
	—	[Cancel] key: shifts to the previous menu. ☞ 5.2.2 Various settings of User type







### Standard Adjust Print menu

Adjusts only the print mode in the user type setting which is currently set.

Setup item	Setting	Description
Adj. Print1 : Standard	Confirm ptn	Print the test pattern for the alignment. Check before adjusting. ☞ 3.7.1.1 Standard confirmation pattern
	Rough adjustment pattern	Perform this when the degree of misalignment is large. Print Adjust pattern and enter the set value. ☞ 3.7.1.2 Standard rough adjustment pattern
	Micro adjustment pattern	Perform this when the degree of misalignment is small. Print Adjust pattern and enter the set value. ☞ 3.7.1.3 Standard fine adjustment pattern
	—	<ul style="list-style-type: none"> <li>• [Cancel] key: shifts to the previous menu.</li> </ul> ☞ 5.5 Cleaning menu







## Custom Adjust Print menu

Perform adjustment for all patterns from A to F.  
All print modes will be adjusted.

Setup item	Setting	Description
Adj. Print2 : Custom	Confirm ptn	The test patterns of A to F will be printed for Adjust print. Check before adjusting.  <a href="#">3.7.2.1 Custom confirmation pattern</a>
	Rough Ptn. ALL	Perform this when the degree of misalignment is large. Print Adjust patterns A to F and enter the set values.  <a href="#">3.7.2.2.1 Rough Ptn. ALL</a>
	Rough Pattern A to F	When the degree of misalign is large, print out an adjust pattern selected from A to F and enter the value.  <a href="#">3.7.2.2.2 Rough Pattern A to F</a>
	Fine Ptn. ALL	Perform this when the degree of misalignment is small. Print Adjust patterns A to F and enter the set values.  <a href="#">3.7.2.3.1 Fine Ptn. ALL</a>
	Fine PatternA to F	When the degree of misalign is small, print out an adjust pattern selected from A to F and enter the value.  <a href="#">3.7.2.3.2 Fine Pattern A to F</a>
	—	<ul style="list-style-type: none"> <li>[Cancel] key: shifts to the previous menu.</li> </ul>  <a href="#">5.3 Setup menu</a>

### 5.2.2.3 PF Adjust menu

Sets up various settings on the Media feed adjustment.  
After changing the media, perform media feed adjustment.

Setup item	Setting	Description
PF Adjust	Initial Print	Performs initial adjust print. • [Enter] key: shifts to the sub menu.  (5.2.2.3.1 Initial Print menu)
	Initial Change	Sets up Initial Adjust Change. • [Enter] key: shifts to the sub menu.  5.2.2.3.2 Init.Adj.Change menu
	Confirm Print	Performs Confirm Print. • [Enter] key: shifts to the sub menu.  5.2.2.3.3 Confirm menu
	Micro Print	Performs Micro Adjustment Print. • [Enter] key: shifts to the sub menu.  5.2.2.3.4 Micro Adj. Print menu
	Micro Change	Sets up Micro Adjustment Change. • [Enter] key: shifts to the sub menu.  5.2.2.3.5 Micro Adj.Change menu
	—	• [Cancel] key: shifts to the previous menu.  5.2 User Type menu

#### 5.2.2.3.1 Initial Print menu

Performs initial adjust print.

Print a “+” mark at the beginning, feed the media according to the setting value, and print another “+” mark.

Measure the length between the “+” marks. If the length differs from the setting value, enter the actual length in the Initial Print menu.

Setup item	Setting	Description
Feed Length	100 mm to <250 mm> to 500 mm	Changes the length (feed length) of the media feed direction for initial adjust print. • [Enter] key: Determines the setting. “Printing” is displayed and initial adjust print starts. After printing, the printer enters Normal.
	—	• [Cancel] key: cancels the setting and shifts to the previous menu.  5.2.2.3 PF Adjust menu



### 5.2.2.3.2 Init.Adj.Change menu

Sets up Initial Adjust Change.

If the initial print result shows that the setting value differs from the actual length, enter the adjustment value (the actual length measured in the initial print).

Setup item	Setting	Description
Init.	<Initial Print menu setting value> ± 50.0 mm	Sets up Initial Adjust Change.
	—	<ul style="list-style-type: none"> <li>• [Enter] key: saves the setting and shifts to the previous menu.</li> <li>• [Cancel] key: cancels the setting and shifts to the previous menu.</li> </ul>  <a href="#">5.2.2.3 PF Adjust menu</a>

### 5.2.2.3.3 Confirm menu

Performs Confirm Print.

After entering the adjustment value in the Initial Print menu, print again for confirmation.

Setup item	Setting	Description
Feed Length	100 mm to <250 mm> to 500 mm	Changes the length (feed length) of the media feed direction for Confirm Print. <ul style="list-style-type: none"> <li>• [Enter] key: Determines the setting. “Printing” is displayed and initial adjust print starts. After printing, the printer enters Normal.</li> </ul>
	—	<ul style="list-style-type: none"> <li>• [Cancel] key: cancels the setting and shifts to the previous menu.</li> </ul>  <a href="#">5.2.2.3 PF Adjust menu</a>

### 5.2.2.3.4 Micro Adj. Print menu

Performs Micro Adjustment Print.

Performs more detailed adjust print than the initial adjust print.

Setup item	Setting	Description
Micro Print	Printing	Prints the following PF pattern (micro adjustment) with a focus on the micro adjustment value. <ul style="list-style-type: none"> <li>• 0%, ±0.05%, ±0.1%, ±0.2%</li> </ul>
	—	<ul style="list-style-type: none"> <li>• [Cancel] key: shifts to the previous menu. Stops printing and returns to the previous menu if printing is in progress.</li> </ul>  <a href="#">5.2.2.3 PF Adjust menu</a>

### 5.2.2.3.5 Micro Adj.Change menu

Sets up Micro Adjustment Change.

Refer to the print results of the micro adjustment printing to enter the micro adjustment value (in pulse).

Setup item	Setting	Description
Micro Adj.Change	-5.00% to <0 %> to 5.00%	Sets up Micro Adjustment Change.
	—	<ul style="list-style-type: none"> <li>• [Enter] key: saves the setting and shifts to the previous menu.</li> <li>• [Cancel] key: cancels the setting and shifts to the previous menu.</li> </ul>  <a href="#">5.2.2.3 PF Adjust menu</a>



### 5.2.2.4 Vacuum Fan menu

Sets up vacuum fan operation.

Setup item	Setting	Description
Vacuum Fan	Low	Set when there is a possibility of a paper jam caused by failure in media loading when using soft media.
	Middle	Set this when using general media and the adsorption power is too strong if it is set to “High”.
	<High>	Set when using general media.
	Off	The vacuum fan is not used. Set when using thick media.
	—	<ul style="list-style-type: none"> <li>• [Enter] key: saves the setting and shifts to the previous menu.</li> <li>• [Cancel] key: cancels the setting and shifts to the previous menu.</li> </ul>  <a href="#">5.2 User Type menu</a>

### 5.2.2.5 Media thickness menu

Functions of media thickness menu differ depending on the media thickness detection settings.

- If the media thickness detection menu is set to Off, use this to enter and set the media thickness.  
 [5.2.2.5.2 Media thickness confirmation menu](#)
- If the media thickness detection menu is set to On, the detected media thickness is displayed.  
 [5.2.2.5.2 Media thickness confirmation menu](#)

For media detection settings, refer to the following.

 [5.2.2.7.1 Media thickness detection \(media initial 1\)](#)

#### 5.2.2.5.1 Media thickness menu

When using the rigid media with a soft printing surface, the media thickness may not be detected correctly.

When this happens, set the media thickness detection menu to Off, measure the media thickness with a tool such as slide gauge, and then enter the media thickness in this menu.



#### WARNING

- **If you set a value smaller than the actual media thickness, the media may touch and break Print head.**

Setup item	Setting	Description
Thickness	0.1 mm to 16.5 mm	Sets the media thickness. <ul style="list-style-type: none"> <li>• [+] key: increases the setting value.</li> <li>• [-] key: decreases the setting value.</li> </ul>
	—	<ul style="list-style-type: none"> <li>• [Enter] key: saves the setting and shifts to the previous menu.</li> <li>• [Cancel] key: cancels the setting and shifts to the previous menu.</li> </ul>  <a href="#">5.2 User Type menu</a>

#### 5.2.2.5.2 Media thickness confirmation menu

Setup item	Setting	Description
Thickness	****mm	Displays the media width detected during media initialization.
	—	<ul style="list-style-type: none"> <li>• [Cancel] key: shifts to the previous menu.</li> </ul>  <a href="#">5.2 User Type menu</a>

### 5.2.2.6 Thickness Adjust menu

Adjusts the media thickness.

Adjust the head height in accordance with the actual media thickness.

Setup item	Setting	Description
Adjust	Media thickness to media thickness + 1.5 mm	Change the media thickness adjustment setting value by operating the following keys. <ul style="list-style-type: none"> <li>• [+] key: increases the setting value.</li> <li>• [-] key: decreases the setting value.</li> <li>• [Enter] key: saves the setting and shifts to the previous menu.</li> </ul> <a href="#">☞ 5.2 User Type menu</a>
	—	<ul style="list-style-type: none"> <li>• [Cancel] key: cancels the setting and shifts to the previous menu.</li> </ul> <a href="#">☞ 5.2 User Type menu</a>

#### NOTE

If the adjustment value is entered to raise the head height, print quality is not guaranteed.



### 5.2.2.7 Media Initial menu

Set the media detection type while initializing the media.

- Media detection setting has two types: “Media thickness” and “Media width/top edge”; You can make settings for each of them.
- Media thickness is saved per media type. Media thicknesses are saved by media type. When an unregistered media type is set, regardless of media detection setting, initial detection of the media thickness is conducted to save the thickness. From the second time, the printer operates according to media detection setting.
- When you want to keep using the media whose thickness and width have already been entered in the printer, if you set the media detection to Off, you can shorten the operation time.

Setup item	Setting	Description
Media Initial	Media initial 1	• Height: set whether or not to detect the media thickness.
	Media initial 2	• Media: Set whether or not to detect the media width and top edge.
	—	<ul style="list-style-type: none"> <li>• [+] key and [-] key: select the menu.</li> <li>• [Enter] key: shifts to the sub menu.</li> <li>• [Cancel] key: shifts to the previous menu.</li> </ul> <a href="#">☞ 5.2 User Type menu</a>

### 5.2.2.7.1 Media thickness detection (media initial 1)

Setup item	Setting	Description
Height	Off	Media thickness is not detected during media initialization. Set the media thickness in the media thickness menu.  <a href="#">5.2.2.5 Media thickness menu</a>
	On	Media thickness is detected during media initialization.
	—	<ul style="list-style-type: none"> <li>• [Enter] key: saves the setting and shifts to the previous menu.</li> <li>• [Cancel] key: cancels the setting and shifts to the previous menu.</li> </ul>  <a href="#">5.2.2.7 Media Initial menu</a>

#### NOTE

Media thickness detection is for stabilizing print quality by keeping the clearance between Print head and media. Detected value may be differ from the actual media size.

#### CAUTION

- If the media thickness detection menu is set to “Off”, media thickness is not detected; follow the procedure below to set the media thickness (value).
1. When “Warning! \*.\* mm ->” (“ \* ” stands for a numerical character) is displayed on the operation panel, check if the value matches the thickness of the loaded media. If the value is wrong, enter the correct setting value.
    - If you can’t figure out the correct value, press the [Cancel] key. The printer starts detecting the media thickness.
    - If a wrong value is set, the head and media collide and may damage the head.
  2. Press the [Enter] key.
  3. When “Misuse Damages Unit>” is displayed on the operation panel, press [>] key for more than two seconds.
  4. When “<E>Skip <CAN>Detect” is displayed on the operation panel, press the [Enter] key.
    - The printer starts performing media initial operation.
    - If you press the [Cancel] key, thickness of the media will be detected.

### 5.2.2.7.2 Media width/top edge detection (media initial 2)

Setup item	Setting	Description
Media	Off	The media width and top edge are not detected during media initialization. Set the media width in the media width menu. <a href="#">🔗 5.2.2.8 Media Width/Width check menu</a>
	Top&Width	Detect the media width and top edge during media initialization.
	<Width>	Media width is detected during media initialization. Top edge of the media is not detected.
	—	<ul style="list-style-type: none"> <li>[Enter] key: saves the setting and shifts to the previous menu.</li> <li>[Cancel] key: cancels the setting and shifts to the previous menu.</li> </ul> <a href="#">🔗 5.2.2.7 Media Initial menu</a>

### 5.2.2.8 Media Width/Width check menu

Media width/Width check menu varies depending on the settings of Media width/top edge detection menu.

- When the media width/top edge detection menu is set to Off, you can enter the media width between 5 mm from the loading mark of Paper guide F and the left edge of the media  
[🔗 5.2.2.8.1 Media Width menu](#)
- If the media width/top edge detection menu is set to either “Top&Width” or “Width”, the detected media width is displayed.  
[🔗 5.2.2.8.2 MediaWidth check menu](#)

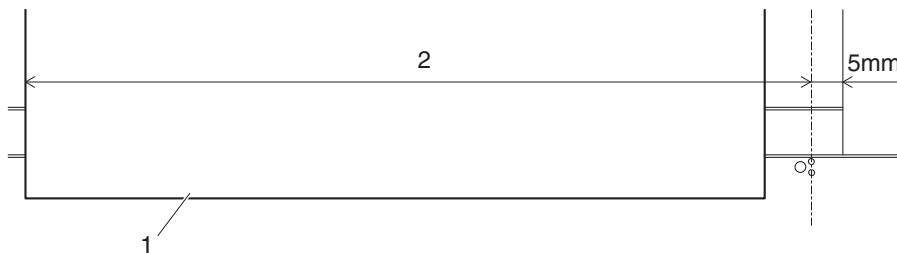

No.	Name
1	Roll media
2	Media width

### 5.2.2.8.1 Media Width menu

#### NOTE

If a larger value than the actual media width is set in the Media Width menu, the ink may be leaked on the media or printer during printing.

Setup item	Setting	Description
Media Width	<1,000 mm> to 1,625 mm	Set the media width when media detection is set to Off.
	—	<ul style="list-style-type: none"> <li>• [Enter] key: saves the setting and shifts to the previous menu.</li> <li>• [Cancel] key: cancels the setting and shifts to the previous menu.</li> </ul>  <a href="#">5.2 User Type menu</a>

### 5.2.2.8.2 MediaWidth check menu

Setup item	Setting	Description
MediaWidth	**** mm	Display the media width that is detected while initializing.
	—	<ul style="list-style-type: none"> <li>• [Cancel] key: shifts to the previous menu.</li> </ul>  <a href="#">5.2 User Type menu</a>

### 5.2.2.9 Strike Wait menu

Set up the strike wait time while overwrite printing as well as regular printing.

Setup item	Setting	Description
Strike Wait	<0.0 sec.> to sec.0.1 sec. to 5.0 sec.	Sets up the waiting interval per print head travel during printing.
	—	<ul style="list-style-type: none"> <li>• [Enter] key: saves the setting and shifts to the previous menu.</li> <li>• [Cancel] key: cancels the setting and shifts to the previous menu.</li> </ul>  <a href="#">5.2 User Type menu</a>

### 5.2.2.10 Rigid/Roll menu

Set which of roll media or rigid media will be used.

**NOTE**

- When Rigid/Roll menu is set as Roll media and if you print on heavy rigid media, it may cause an error during printing. Also, when Rigid/Roll menu is set as Rigid media and if you print on the roll media, it may cause affect print quality.
- Make sure that you change the settings deepening on the media type, and then start printing.

Setup item	Setting	Description
Rigid/ Roll	<Roll>	Set when using roll media.
	Rigid	Set when using rigid media.
	—	<ul style="list-style-type: none"> <li>• [Enter] key: saves the setting and shifts to the previous menu.</li> <li>• [Cancel] key: cancels the setting and shifts to the previous menu.</li> </ul> <a href="#">👉 5.2 User Type menu</a>



### 5.2.2.11 Show Edges menu

With this setting, you can check the printing area (print start position and data width) with the LED pointer before printing to pre-check the following situations:

- Whether the printing area and media position are misaligned
- Whether the printing area is larger than the media width

The Show Edges Operations:

- The LED pointer indicates the printing area (in Y-direction).
- The LED light blinks at Position 1 (1Hz).
- The LED pointer moves to Position 2 (LED light: ON).
- If the data width is larger than the media width, the LED light blinks fast at Position 2 (2Hz).
- The LED pointer moves to Position 1 => Position 2.

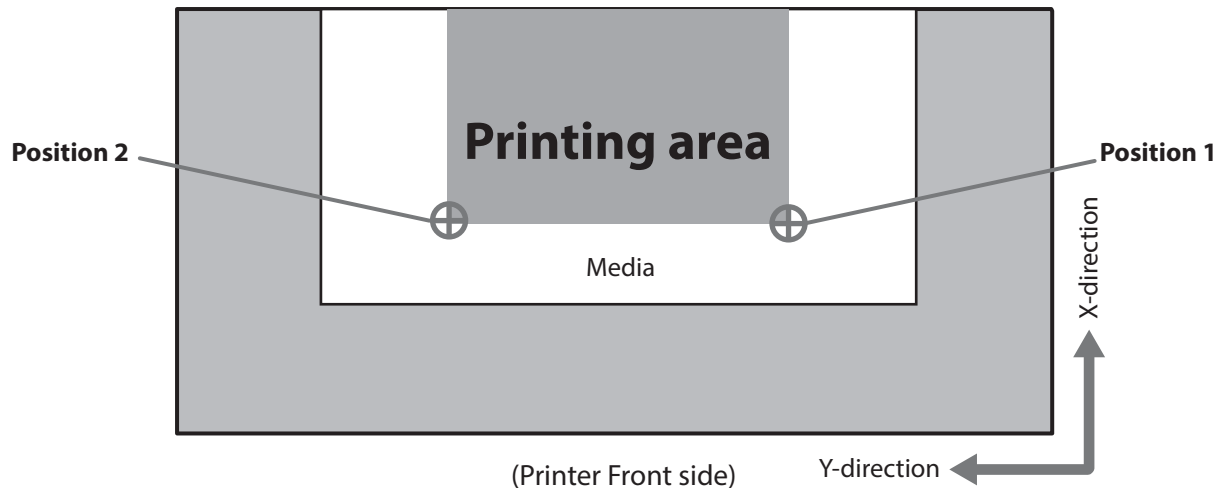

Setup item	Setting	Description
Show Edges	<Off>	Show Edges is Off.
	Step	The Show Edges operation proceeds with user confirmation at each step of its process.
	Auto	The Show Edges operation proceeds without user confirmation.
	—	<ul style="list-style-type: none"> <li>• [Enter] key: saves the setting and shifts to the previous menu.</li> <li>• [Cancel] key: cancels the setting and shifts to the previous menu.</li> </ul> <a href="#">📖 5.2 User Type menu</a>

**NOTE**

- With take-up system, the LED pointer indicates the points more ahead of the actual print start position.  
Use this function as reference of the data width.
- When “Step” is selected:
  1. Press [Enter] to proceed the operation in each message below:
    - “Start Show Edges -> E”
    - “Position 1 OK?”
    - “Start Printing?”
  2. Press [Cancel] to cancel the printing.
- When “Step” is selected:  
Do not spend more than 30 seconds on each entry. If so, the process is back to the beginning.
- When “Start Printing?” appears after “Auto” is selected:
  1. Press [Enter] to start printing.
  2. Press [Cancel] to cancel the printing.

**5.2.2.12 Initialization menu**

Returns all settings of User type to factory default.

Setup item	Setting	Description
Initialization	—	<ul style="list-style-type: none"> <li>• [Enter] key: initializes the setting and shifts to Normal display (“Ready to Print”).</li> </ul>
	—	<ul style="list-style-type: none"> <li>• [Cancel] key: shifts to the previous menu.</li> </ul> <a href="#">☞ 5.2 User Type menu</a>

### 5.2.2.13 Add Y Layer (available in 6-color configuration)

This function is available in 6-color set. When “Add Y Layer” is set to ON, the yellow layer is added underneath of the White-underlay or Three-layer print data to preserve the color of the white layer and the color layer overlaid.

Setup item	Setting	Description
Add Y Layer	<Off>	<ul style="list-style-type: none"> <li>Yellow layer is not added.</li> </ul>
	On	<ul style="list-style-type: none"> <li>Add the yellow layer under the white layer of White-underlay or Three-layer print data.</li> </ul>
	—	<ul style="list-style-type: none"> <li>[Enter] key: saves the setting and shifts to the previous menu.</li> <li>[Cancel] key: shifts to the previous menu.</li> </ul> <p> <a href="#">5.2 User Type menu</a></p>

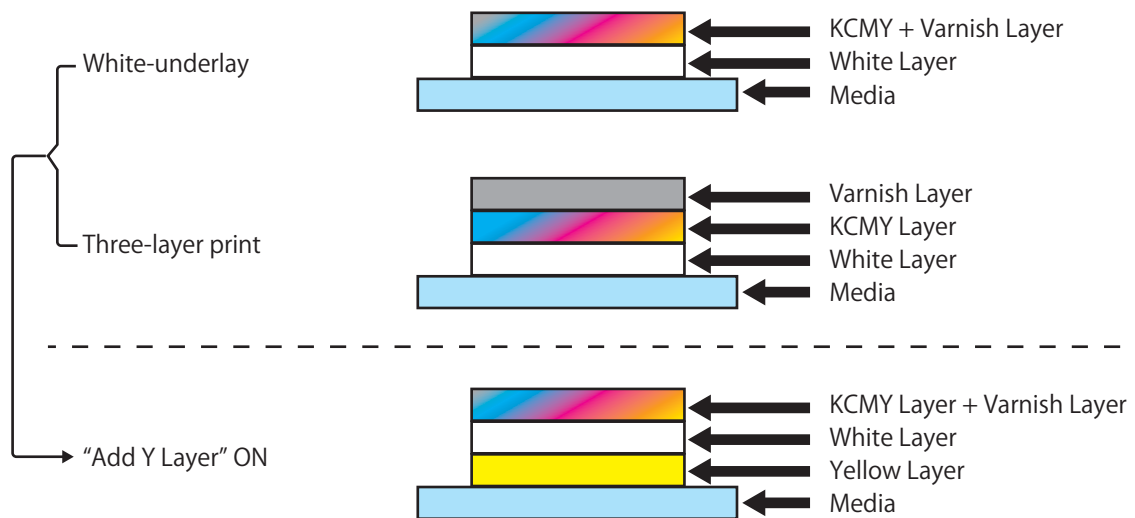









**NOTE**

In Three-layer print data, when “Add Y Layer” is set to ON, varnish is blended into KCMY layer as top layer.

## 5.3 Setup menu

Various settings of the printer are configured.

Setup item	Description
Side Margin	Specifies the right and left margins of printed media. <ul style="list-style-type: none"> <li>[Enter] key: shifts to the sub menu.</li> </ul> <a href="#">☞ 5.3.1 Side Margin menu</a>
Take-up	Set the operation of the optional take-up unit. <ul style="list-style-type: none"> <li>[Enter] key: shifts to the sub menu.</li> </ul> <a href="#">☞ 5.3.2 Take-up menu</a>
Media loading position	Set the media loading position manually if you are using the media that cannot be detected, such as transparent media. <ul style="list-style-type: none"> <li>[Enter] key: shifts to the sub menu.</li> </ul> <a href="#">☞ 5.3.3 Media loading position</a>
Origin	Sets the beginning of printing (origin) of the print data. <ul style="list-style-type: none"> <li>[Enter] key: shifts to the sub menu.</li> </ul> <a href="#">☞ 5.3.4 Origin menu</a>
Head Travel	Sets up the range that the print head moves while printing. <ul style="list-style-type: none"> <li>[Enter] key: shifts to the sub menu.</li> </ul> <a href="#">☞ 5.3.5 Head Travel menu</a>
Multi Strike	Sets up the multi strike count per line. <ul style="list-style-type: none"> <li>[Enter] key: shifts to the sub menu.</li> </ul> <a href="#">☞ 5.3.6 Multi Strike count menu</a>
Slant Check	Sets up slanting detection during media loading. <ul style="list-style-type: none"> <li>[Enter] key: shifts to the sub menu.</li> </ul> <a href="#">☞ 5.3.7 Slant Check menu</a>
Auto Cleaning	Sets up the time for auto cleaning during printing. <ul style="list-style-type: none"> <li>[Enter] key: shifts to the sub menu.</li> </ul> <a href="#">☞ 5.3.8 Auto Cleaning menu</a>
Roll Length	Sets up the roll media length. <ul style="list-style-type: none"> <li>[Enter] key: shifts to the sub menu.</li> </ul> <a href="#">☞ 5.3.9 Roll Length menu</a>
FrontInterlace	Sets the media edge treatment function. <ul style="list-style-type: none"> <li>[Enter] key: shifts to the previous menu.</li> </ul> <a href="#">☞ 5.3.10 FrontInterlace Menu</a>
BottomInterlace	Sets the BottomInterlace function. <ul style="list-style-type: none"> <li>[Enter] key: shifts to the previous menu.</li> </ul> <a href="#">☞ 5.3.11 BottomInterlace menu</a>
CR Mainte.	Performs maintenance. <ul style="list-style-type: none"> <li>[Enter] key: shifts to the sub menu.</li> </ul> <a href="#">☞ 5.3.12 CR Maintenance menu</a>
Ink Status	Displays information of ink cartridge. <ul style="list-style-type: none"> <li>[Enter] key: shifts to the sub menu.</li> </ul> <a href="#">☞ 5.3.13 Ink Status menu</a>

Setup item	Description
Life Times	Displays the operational life time of each part. <ul style="list-style-type: none"> <li>• [Enter] key: shifts to the sub menu.</li> </ul>  <a href="#">5.3.14 Life Times menu</a>
Header Dump	Sets whether to print the following information (damp data) when printing. <ul style="list-style-type: none"> <li>• Data header</li> <li>• Data dot number (printed only when Header damp setting is ON)</li> <li>• Printer serial number</li> <li>• Firmware version</li> </ul> <ul style="list-style-type: none"> <li>• [Enter] key: shifts to the sub menu.</li> </ul>  <a href="#">5.3.15 Header Dump menu</a>
Exhaust fan	Sets up exhaust fan operation. <ul style="list-style-type: none"> <li>• [Enter] key: shifts to the sub menu.</li> </ul>  <a href="#">5.3.16 Exhaust fan menu</a>
White maintenance	Sets up white ink's maintenance operation. <ul style="list-style-type: none"> <li>• [Enter] key: shifts to the sub menu.</li> </ul>  <a href="#">5.3.17 White maintenance menu</a>
Start Feed	You can change the margin setting between images. <ul style="list-style-type: none"> <li>• [Enter] key: shifts to the sub menu.</li> </ul>  <a href="#">5.3.18 Start Feed menu</a>
Initialization	Returns each setting of the printer to default. <ul style="list-style-type: none"> <li>• [Enter] key: shifts to the sub menu</li> </ul>  <a href="#">5.3.19 Initialization menu</a>
Spitting	Sets up the Spitting operation while printing. <ul style="list-style-type: none"> <li>• [Enter] key: shifts to the sub menu.</li> </ul>  <a href="#">5.3.20 Spitting menu</a>
Temporary	Displays the menus which have been set to hide in the Menu Option menu temporarily. <ul style="list-style-type: none"> <li>• [Enter] key: returns to the previous menu with all set up items displayed.</li> <li>• [Cancel] key: returns to the mode set in Menu option menu with all setup items displayed.</li> </ul>  <a href="#">5.6 Menu Option menu</a>
—	<ul style="list-style-type: none"> <li>• [Cancel] key: shifts to the previous menu.</li> </ul>  <a href="#">5 Panel setup menu</a>

### 5.3.1 Side Margin menu

Set up the right and left margins (side margins) while printing.

#### NOTE

- When the Spitting menu is set to “On Media”, the maximum printable media width becomes 16 mm shorter.  
Therefore, the side margins become the value that you have set in Side Margin menu +8 mm.  
[🔗 5.3.20 Spitting menu](#)
- The right side margin will be the following sum depending on the setting.  
Y of Origin menu + 8 mm (when the spitting is set to On Media) + Value set in Side Margin menu.

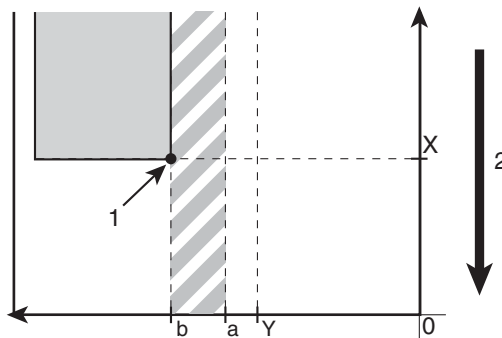

1. Print starting position
2. Media feed direction

X (media feeding distance)

Y (print head transferring distance)

a (0 mm / 8 mm: Spitting setting is ON, Off / On Media)

b (5 mm to 25 mm: Side margin setting)

[🔗 5.3.20 Spitting menu](#)

[🔗 5.3.4 Origin menu](#)

Setup item	Setting	Description
Side Margin	<5 mm> to 25 mm	Set the side margins.
	—	<ul style="list-style-type: none"> <li>[Enter] key: saves the setting and shifts to the previous menu.</li> <li>[Cancel] key: cancels the setting and shifts to the previous menu.</li> </ul> <a href="#">🔗 5.3 Setup menu</a>

### 5.3.2 Take-up menu

Set the operation of the optional take-up unit.

#### NOTE

When the take-up unit is not installed, do not set the “Take-up menu” to “On”.  
By doing so, the product will be unable to function properly.

#### TIP

For details about the optional take-up unit, contact your local MUTOH dealer.

Setup item	Setting	Description
Take-up	<Off>	The take-up unit is not used.
	On	Set to use the optional take-up unit.
	—	<ul style="list-style-type: none"> <li>• [Enter] key: saves the setting and shifts to the previous menu.</li> <li>• [Cancel] key: cancels the setting and shifts to the previous menu.</li> </ul> <a href="#">☞ 5.3 Setup menu</a>

#### 5.3.2.1 Page Gap menu

When “Take-up menu” is set to “On”, the menu is shifted to “Page Gap”.

In the Page Gap menu, you can change the margin setting between images.

Setup item	Setting	Description
Page Gap	<Normal>	The default margin setting between images will be applied.
	Narrow	The margin setting between images is smaller than Normal.
	—	<ul style="list-style-type: none"> <li>• [Enter] key: saves the setting and shifts to the previous menu.</li> <li>• [Cancel] key: cancels the setting and shifts to the previous menu.</li> </ul> <a href="#">☞ 5.3.2 Take-up menu</a>



### 5.3.3 Media loading position

Set the media loading position manually if you are using the media that cannot be detected, such as transparent media.

**NOTE**

- This menu is only available when the media width/top edge detection (media initial 2) is set to “Off” or “Width”.  
 [5.2.2.7.2 Media width/top edge detection \(media initial 2\)](#)
  - This menu is only available for the media that is loaded.  
If the media loading position is changed after replacing the media, set this menu again.
-

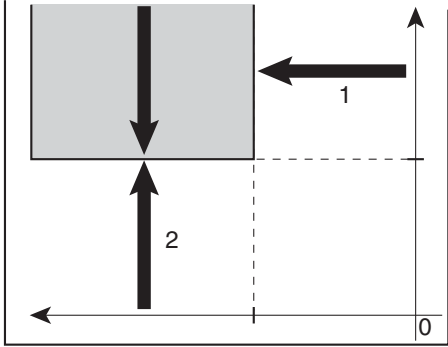

Setup item	Setting	Description
Media loading position	Side edge: -0 mm to +1,625 mm Top edge: -1,200 mm to +1,200 mm	<ul style="list-style-type: none"> <li>Side edge: set the right edge position of the media. The higher the entered value, the further toward the opposite of the origin side Print head moves.</li> <li>Top edge: set the top edge position of the media. The higher the entered value, the more media is fed.</li> </ul> <p>Change Print head position and media feeding distance with the following keys.</p> <ul style="list-style-type: none"> <li>[&gt;] key: moves the cursor to the next digit.</li> <li>[&lt;] key: moves the cursor to the previous digit.</li> <li>[+] key: increases the setting value.</li> <li>[-] key: decreases the setting value.</li> </ul>  <ol style="list-style-type: none"> <li>Side edge detection direction</li> <li>Top edge detection direction</li> </ol> <ul style="list-style-type: none"> <li>[Enter] key:                             <ul style="list-style-type: none"> <li>“Wait for a while” is displayed on Operation panel, and the LED pointer moves to the position of the entered value.</li> <li>If the LED pointer is not just at the edge of the media, change the entered value and press the [Enter] key.</li> <li>When the pointer is placed at the correct location, press the [Enter] key and confirm. Moves on to the next setting.</li> </ul> </li> </ul>
	Media width: 175 mm to +1,625 mm - Side edge setting value	<ul style="list-style-type: none"> <li>Media width: set the media width. Enter the number for the media width.</li> </ul>
	—	<ul style="list-style-type: none"> <li>[Cancel] key: cancels the setting and shifts to the previous menu.</li> </ul> <p> <a href="#">5.3 Setup menu</a></p>

### 5.3.4 Origin menu

Sets the beginning of printing (origin) of the print data.

Set this when you want to print on the margin areas of the media that is already printed on, or when you want to print on the object that is set on the jig.

#### NOTE

- When the Take-up menu is set to “On”, the setting value for X (media feeding distance) is between 15 mm and 999.9 mm.  
[☞ 5.3.2 Take-up menu](#)
- Depending on the setting value of the side margins, the maximum setting value of Y (print head transferring distance) decreases.  
[☞ 5.3.1 Side Margin menu](#)

Setup item	Setting	Description
Origin	<Off>	The origin position is not set
	On	You can set the origin position.
	—	<ul style="list-style-type: none"> <li>• [+] key and [-] key: select the menu.</li> <li>• [Enter] key: enter the origin position.</li> <li>• [Cancel] key: cancels the setting and shifts to the previous menu.</li> </ul> <a href="#">☞ 5.3 Setup menu</a>

<Enter the origin position>

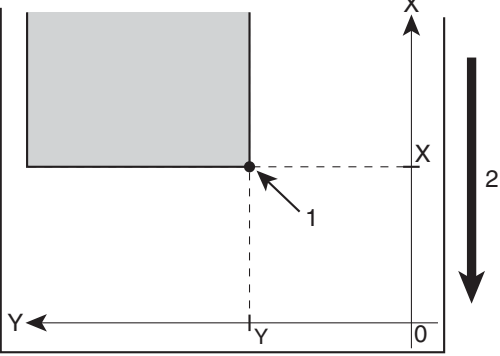
Setup item	Setting	Description
Origin	<ul style="list-style-type: none"> <li>X (media feeding distance): 15.0 mm to 999.9 mm</li> <li>Y (print head transferring distance): 5.0 mm to 1,405.0 mm</li> </ul>	<p>Change the print head position and media feeding distance with the following keys.</p> <ul style="list-style-type: none"> <li>[&gt;] key: Decreases the print head transferring distance.</li> <li>[&lt;] key: Increases the print head transferring distance.</li> <li>[+] key: Decreases the media feeding distance.</li> <li>[-] key: Increases the media feeding distance.</li> </ul>  <p>1.Starting position 2.Media feeding direction</p> <ul style="list-style-type: none"> <li>[Enter] key: “Moving Origin Pos.” is displayed and Print head moves to the starting position with the LED pointer on.</li> <li>After Print head has moved to the origin position, and if you want to change the position, adjust the position using Operation panel again.</li> </ul>
	Confirm Position→Enter	<ul style="list-style-type: none"> <li>[Enter] key or after a certain period of time: Determines the setting. Print head returns to the original position. Save the setting and shift to the previous menu. <a href="#">5.3 Setup menu</a></li> </ul>
	—	<ul style="list-style-type: none"> <li>[Cancel] key: cancels the setting and shifts to the previous menu. <a href="#">5.3 Setup menu</a></li> </ul>

### 5.3.5 Head Travel menu

Sets up the range that Print head moves while printing.

Setup item	Setting	Description
Distance	Data	Print head moves the range of the print data width. The printing speed will be improved since the moving range of Print head is optimized.
	Machine	Print head moves from origin to the maximum printable media width.
	<MediaWidth>	Print head shifts within the media width.
	Data Edge	Print head only travels within the range where the image exist. Since this setting can optimize the head traveling width, the printing speed will be faster compared to "Data" setting.
	—	<ul style="list-style-type: none"> <li>• [Enter] key: saves the setting and shifts to the previous menu.</li> <li>• [Cancel] key: cancels the setting and shifts to the previous menu.</li> </ul>  <a href="#">5.3 Setup menu</a>

### 5.3.6 Multi Strike count menu

Sets up the overwrite count per line.

The printer prints over the printed result times the set number of time, making the print results darker.

#### NOTE

When using 6 colors, if "Multi Strike" is set to one time, the menu shifts to [5.3.6.1 Layer Multi Strike menu](#).

Setup item	Setting	Description
Multi Strike	<1 times> to 9 times	Sets up the Muliti Strike count per line.
	—	<ul style="list-style-type: none"> <li>• [Enter] key: saves the setting and shifts to the previous menu. Note that when using 6 colors and "Multi Strike" is set to one time, the menu shifts to the next menu.</li> <li>• [Cancel] key: cancels the setting and shifts to the previous menu.</li> </ul>  <a href="#">5.3 Setup menu</a>

### 5.3.6.1 Layer Multi Strike menu

You can set the number of multi strikes for each layer when performing layer printing.

**NOTE**

Layer printing depends on the function of the RIP software supported.

Setup item	Setting	Description
Layer Multi Strike	1: Co	Shifts to the Multi strike settings for Cyan (C), Magenta (M), Yellow (Y), and Black (K). ☞ 5.3.6.1.1 Color Layer menu
	2: Wh	Shifts to the Multi strike settings for White (Wh) ink. ☞ 5.3.6.1.2 White Layer menu
	3: Va	Shifts to the Multi strike settings for Varnish (Va) ink. ☞ 5.3.6.1.3 Varnish Layer menu
	—	<ul style="list-style-type: none"> <li>[Enter] key: shifts to the sub menu.</li> <li>[Cancel] key: cancels the setting and shifts to the previous menu.</li> </ul> ☞ 5.3 Setup menu

#### Ink film thickness

Ink film thickness changes depending on the set number of multi strikes to be layered. The following is an example when the print mode is set to 720dpi × 1440dpi (Graphics1 / Graphics2).

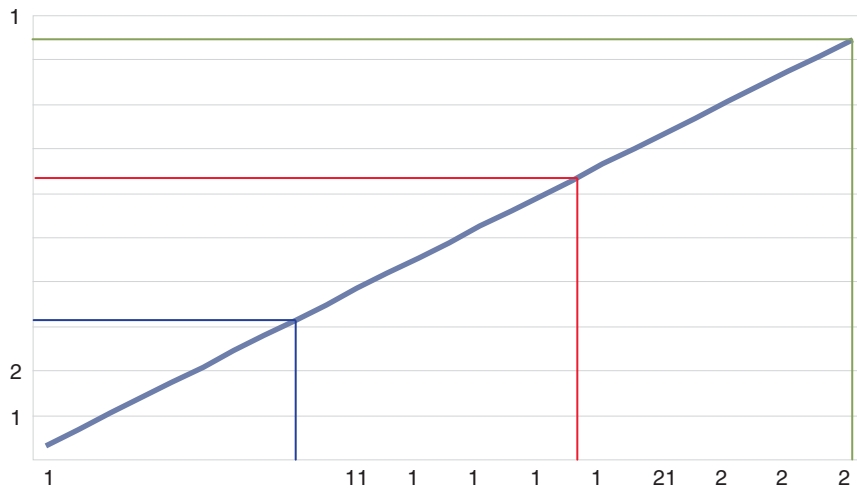

**NOTE**

- The more number of strikes, the thicker the ink film becomes. Note that depending on the media being used, the print head and ink film may come in contact and break the print head.
- Ink film thickness differs by print mode.

### 5.3.6.1.1 Color Layer menu

Shifts to the Multi strike settings for Cyan (C), Magenta (M), Yellow (Y), and Black (K).

Setup item	Setting	Description
Color	1 to 9 times	Sets up the number of Multi strike.
	—	<ul style="list-style-type: none"> <li>• [Enter] key: saves the setting and shifts to the previous menu.</li> <li>• [Cancel] key: cancels the setting and shifts to the previous menu.</li> </ul>  <a href="#">5.3 Setup menu</a>

### 5.3.6.1.2 White Layer menu

Sets up the number of Multi strike for the White (Wh) layer.

Setup item	Setting	Description
White	1 to 9 times	Sets up the number of Multi strike.
	—	<ul style="list-style-type: none"> <li>• [Enter] key: saves the setting and shifts to the previous menu.</li> <li>• [Cancel] key: cancels the setting and shifts to the previous menu.</li> </ul>  <a href="#">5.3 Setup menu</a>

### 5.3.6.1.3 Varnish Layer menu

Sets up the number of Multi strike for the Varnish (Va) layer.

Setup item	Setting	Description
Varnish	1 to 9 times	Sets up the number of Multi strike.
	—	<ul style="list-style-type: none"> <li>• [Enter] key: saves the setting and shifts to the previous menu.</li> <li>• [Cancel] key: cancels the setting and shifts to the previous menu.</li> </ul>  <a href="#">5.3 Setup menu</a>

### 5.3.7 Slant Check menu

Sets up slanting detection during media loading.

Setup item	Setting	Description
Slant Check	<Off>	Slant Check is not performed.
	On	Slant Check is performed.
	—	<ul style="list-style-type: none"> <li>[Enter] key: saves the setting and shifts to the previous menu.</li> <li>[Cancel] key: cancels the setting and shifts to the previous menu.</li> </ul> <a href="#">☞ 5.3 Setup menu</a>

### 5.3.8 Auto Cleaning menu

Configure the settings for the auto cleaning operation.

Setup item	Setting	Description
Auto Cleaning	Waiting	Set the value for auto-cleaning in standby mode. <a href="#">☞ 5.3.8.1 Waiting Auto Cleaning</a>
	Printing	Set the value for auto cleaning while printing one print job. <a href="#">☞ 5.3.8.2 Printing Auto Cleaning</a>
	Before Print	Set the value for auto cleaning before printing. <a href="#">☞ 5.3.8.3 Before Print Auto Cleaning</a>
	Accum. Print	Set the value for auto cleaning while continuously printing multiple print jobs. <a href="#">☞ 5.3.8.4 Accum. Print Auto Cleaning</a>

#### NOTE

- Auto cleaning is not performed before Test Print.
- The difference between “Printing Auto Cleaning” and “Accum. Print Auto Cleaning” is as follows:
  - Printing Auto Cleaning:  
It performs auto cleaning while printing one print job.
  - Accum. Print Auto Cleaning:  
It performs auto cleaning while continuously printing multiple print jobs.

Printing Auto Cleaning

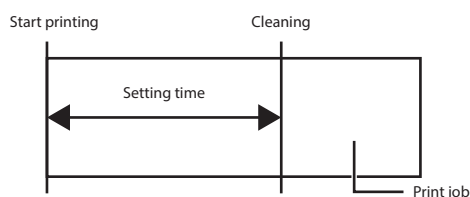

Accum. Print Auto Cleaning

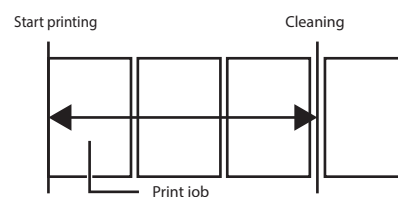

### 5.3.8.1 Waiting Auto Cleaning

#### (1) Waiting 1 (type)

Select the type for auto cleaning.

Setup item	Setting	Description
Waiting 1 (type)	<Off>	<ul style="list-style-type: none"> <li>• Off: Auto cleaning is not performed during printing.</li> <li>• Short: Discharges smaller amount of ink compared to Normal.</li> <li>• Normal: Performs normal cleaning.</li> <li>• Long: Discharges a larger amount of ink compare to Normal. Used when Print head does not improve by normal Head cleaning.</li> </ul>
	Short	
	Normal	
	Long	
	—	<ul style="list-style-type: none"> <li>• [Enter] key: saves the setting and shifts to the previous menu.</li> <li>• [Cancel] key: cancels the setting and shifts to the previous menu.</li> </ul> <a href="#">🔗 5.3.8 Auto Cleaning menu</a>

#### (2) Waiting 2 (time)

Set the auto cleaning interval during standby.

#### NOTE

If you set the time for Waiting Time Auto Cleaning longer than the default setting, nozzles may get clogged.

Setup item	Setting	Description
Waiting 2 (time)	1h to <6h> to 24 h	Set the auto cleaning interval for the standby mode
	—	<ul style="list-style-type: none"> <li>• [Enter] key: saves the setting and shifts to the previous menu.</li> <li>• [Cancel] key: cancels the setting and shifts to the previous menu.</li> </ul> <a href="#">🔗 5.3.8 Auto Cleaning menu</a>



### 5.3.8.2 Printing Auto Cleaning

Set the auto cleaning while printing one print job.

#### (1) Printing 1 (type)

Select the type for auto cleaning.

Setup item	Setting	Description
Printing 1	<Off>	<ul style="list-style-type: none"> <li>• Off: Auto cleaning is not performed during printing.</li> <li>• Short: Discharges smaller amount of ink compared to Normal.</li> <li>• Normal: Performs normal cleaning.</li> <li>• Long: Discharges a larger amount of ink compare to Normal. Used when Print head does not improve by normal head cleaning.</li> </ul>
	Short	
	Normal	
	Long	
	—	<ul style="list-style-type: none"> <li>• [Enter] key: saves the setting and shifts to the previous menu.</li> <li>• [Cancel] key: cancels the setting and shifts to the previous menu.</li> </ul> <p> <a href="#">5.3.8 Auto Cleaning menu</a></p>

#### (1) Printing 2 (time)

Set the auto cleaning interval during printing.

Setup item	Setting	Description
Printing 2	1h to <6h> to 24h	Selects the time for auto cleaning while printing.
	—	<ul style="list-style-type: none"> <li>• [Enter] key: saves the setting and shifts to the previous menu.</li> <li>• [Cancel] key: cancels the setting and shifts to the previous menu.</li> </ul> <p> <a href="#">5.3.8 Auto Cleaning menu</a></p>

### 5.3.8.3 Before Print Auto Cleaning

Set the value for auto cleaning before printing.

Setup item	Setting	Description
Before Print	<Off>	<ul style="list-style-type: none"> <li>• Off: Auto cleaning is not performed before printing.</li> <li>• Short: Discharges smaller amount of ink compared to Normal.</li> <li>• Normal: Performs Normal cleaning.</li> <li>• Long: Discharges a larger amount of ink compare to Normal. Used when Print head does not improve by normal head cleaning.</li> </ul>
	Short	
	Normal	
	Long	
	—	<ul style="list-style-type: none"> <li>• [Enter] key: saves the setting and shifts to the previous menu.</li> <li>• [Cancel] key: cancels the setting and shifts to the previous menu.</li> </ul>  <a href="#">5.3.8 Auto Cleaning menu</a>



### 5.3.8.4 Accum. Print Auto Cleaning

Set the value for auto cleaning while continuously printing multiple print jobs.

Setup item	Setting	Description
Accum. Print	<Off>	Auto cleaning is not performed during printing.
	1h / 2h / 3h / 4h	Set the timer since the start of printing to perform auto cleaning. The printer automatically performs cleaning when the timer is turned on.
	—	<ul style="list-style-type: none"> <li>• [Enter] key: saves the setting and shifts to the previous menu.</li> <li>• [Cancel] key: cancels the setting and shifts to the previous menu.</li> </ul>  <a href="#">5.3.8 Auto Cleaning menu</a>

### 5.3.9 Roll Length menu

Select the setting for the roll media length you are using.

Setup item	Setting	Description
RollKind	<Off>	Roll Length is not used. • [Enter] key: saves the setting and shifts to the previous menu.  <a href="#">5.3 Setup menu</a>
	Roll 1	Sets up the roll media length. The Roll Length setting is set for three types as “Roll 1” to “Roll 3”. • [Enter] key: saves the setting and shifts to the sub menu.  <a href="#">5.3.9.1 Length menu</a>
	Roll 2	
	Roll 3	
	—	• [Cancel] key: cancels the setting and shifts to the previous menu.  <a href="#">5.3 Setup menu</a>

#### 5.3.9.1 Length menu

Sets up the roll media length.

**NOTE**

When replacing the roll media, adjust the roll media length again.  
If the roll media length is not set, the residual quantity of roll media is not displayed correctly.

Setup item	Setting	Description
Length	1 m to <30 m> to 200 m	Set the roll media length.
	—	• [Enter] key: saves the setting and shifts to the previous menu. • [Cancel] key: cancels the setting and shifts to the previous menu.  <a href="#">5.3.9 Roll Length menu</a>

### 5.3.10 FrontInterlace Menu

This menu is used to set media edge treatment menu. Select AUTO under normal condition.

Setup item	Setting	Description
FrontInterlace	<AUTO>	Performs media edge treatment automatically when required.
	Off	Media edge treatment is not performed.
	—	<ul style="list-style-type: none"> <li>• [Enter] key: saves the setting and shifts to the previous menu.</li> <li>• [Cancel] key: shifts to the previous menu.</li> </ul> <a href="#">🔗 5.3 Setup menu</a>

#### NOTE

To set Paper Interlace OFF, set the “FrontInterlace” setting value as ON (display) in the Simple select menu, and then change the set values of “FrontInterlace” from the Setup menu.

[🔗 5.6 Menu Option menu](#)

### 5.3.11 BottomInterlace menu

Sets the BottomInterlace function.

If the print is missing or blurred, specify the end edge treatment to “Off”.

Setup item	Setting	Description
BtmInterlace	Off	The BottomInterlace function is not used.
	<On>	The BottomInterlace function is used.
	—	<ul style="list-style-type: none"> <li>• [Cancel] key: saves the setting and shifts to the previous menu.</li> </ul> <a href="#">🔗 5.3 Setup menu</a>

#### NOTE

Even if the end edge treatment is set to “Off”, the treatment for end edge of media (media end) will be executed.

[🔗 5.3 Setup menu](#)

### 5.3.12 CR Maintenance menu

Use this for replacing absorption material for the flushing box and the cleaning wiper.

[☞ 6.4.3 Replacing the flushing-box sponges](#)

[☞ 6.4.4 Replacing the cleaning wiper](#)

If you want to clean the printer in cases described in “5.7.1 Daily Maintenance menu”, go to Daily Maintenance Menu.

[☞ 5.7.1 Daily Maintenance menu](#)

#### NOTE

When the CR maintenance menu is displayed, even leaving the keys untouched for three minutes does not return to the printer to normal status.

[☞ 2.3 Printer status](#)

Setup item	Setting	Description
CR Maint.	Start	Performs maintenance. • [Enter] key: The print head moves to the left. The cleaning wiper raises.
	End	Completes maintenance. • [Enter] key: The print head returns to its original position. The cleaning wiper returns to its original position.
	—	• [Cancel] key: shifts to the previous menu without maintenance. <a href="#">☞ 5.3 Setup menu</a>

### 5.3.13 Ink Status menu

Displays the various information about ink cartridge.

#### NOTE

- To display the Ink Status menu, use the genuine ink cartridge.  
If you use an ink cartridge other than the genuine one, ink status is not displayed correctly.
- In the ink status menu, ink colors are displayed with the slot numbers.

<When using 6-color set>

- 1: Black (K)
- 2: Cyan (C)
- 3: Magenta (M)
- 4: Yellow (Y)
- 5: Varnish (VA)
- 6: White (WH)

<When using 4-color set>

- 1: Magenta (M)
- 2: Magenta (m)
- 3: Cyan (C)
- 4: Cyan (c)
- 5: Black (K)
- 6: Yellow (Y)

<When using 6-color set>

Setup item	Setting	Description
Ink status	1234	Each remaining ink for K/C/M/Y is displayed in a range of 0 to 100 (%).
	56	The amount of remaining V/W ink is displayed in a range of 0 to 100 (%).
	—	<ul style="list-style-type: none"> <li>• [Cancel] key: shifts to the previous menu.</li> </ul>  <a href="#">5.3 Setup menu</a>

**<When using 4-color set>**

Setup item	Setting	Description
Ink status	1234	Each remaining ink for M/m/C/c is displayed in a range of 0 to 100 (%).
	56	Each remaining ink for K/Y is displayed in a range of 0 to 100 (%).
	—	<ul style="list-style-type: none"> <li>[Cancel] key: shifts to the previous menu.</li> </ul>  <a href="#">5.3 Setup menu</a>

**5.3.14 Life Times menu**

Displays the operational life time of each part.

Setup item	Setting	Description
Life Times	Head	Display the life of each part. <ul style="list-style-type: none"> <li>The lifetime of each part is indicated by the asterisks (Maximum 5 asterisks: 100% left).</li> <li>As the part deteriorates, the number of asterisks decreases one by one (20%).</li> <li>The part should be changed when all of the asterisks have disappeared, and “Change” is displayed. Contact your local MUTOH dealer to ask for replacing parts.</li> </ul>
	Pump	
	CR Motor	
	PF Motor	
	C Pump	
	UV LED	
	—	<ul style="list-style-type: none"> <li>[Cancel] key: shifts to the previous menu.</li> </ul>  <a href="#">5.3 Setup menu</a>

### 5.3.15 Header Dump menu

Sets whether to print the following information (dump data) when printing.

- Data header
- Data dot number (printed only when Header dump setting is ON)
- Printing date and time
- Printer serial number
- Firmware version
- Receiving time (printed only when Header dump setting is “Dump”)
- Receiving size (printed only when Header dump setting is “Dump”)

The data will be useful when contacting technical support.

#### NOTE

Performing printing if the printer is connected to PC, the print settings of RIP soft you are using are printed on “Data header”.

Setup item	Setting	Description
Header Dump	<Off>	Prints only the data to be printed. Dump data is not printed.
	On	Dump data is printed after the original image is printed.
	Dump	Prints only dump data. “Data dot number” is not printed. The original image is not printed.
	Print	Prints the last header dump. If no history is available, “No Print Data” will appear on the operation panel.
	—	<ul style="list-style-type: none"> <li>• [Cancel] key: shifts to the previous menu.</li> </ul>  <a href="#">5.3 Setup menu</a>



### 5.3.16 Exhaust fan menu

Sets up exhaust fan operation.

Ventilates the inside of the printer to stabilize the parts performance. It also decreases the contamination by ink mist inside the printer. We recommend that you use exhaust fan, especially when printing for a long time.

Setup item	Setting	Description
Exhaust fan	Off	Turn Off the exhaust fan.
	<Low>	Start the exhaust fan at Low.
	High	Start the exhaust fan at High.
	—	<ul style="list-style-type: none"> <li>• [Enter] key: saves the setting and shifts to the previous menu.</li> <li>• [Cancel] key: cancels the setting and shifts to the previous menu.</li> </ul> <a href="#">☞ 5.3 Setup menu</a>

### 5.3.17 White maintenance menu

Sets up white ink's maintenance operation.

White ink tends to settle or coagulate inside the print head or ink tubes. Therefore, the printer regularly discharges a small amount of white ink to maintain the performance, even in standby status.

If you do not usually use white ink for regular printing, set to "Little" to curb white ink consumption in standby status.

Setup item	Setting	Description
White Mainte.	<Normal>	Performs white ink maintenance regularly to avoid clogging of the print head or ink tubes. This should normally be set.
	Little	Reduces white ink maintenance operation. You can curb ink consumption when this is set. However, we recommend not setting this if you use white ink for regular printing.
	—	<ul style="list-style-type: none"> <li>• [Enter] key: saves the setting and shifts to the previous menu.</li> <li>• [Cancel] key: cancels the setting and shifts to the previous menu.</li> </ul> <a href="#">☞ 5.3 Setup menu</a>

#### NOTE

- White ink printing tends to create unevenness of contrasting density.
- To clear the unevenness of contrasting density by white ink, perform cleaning or micro charging a few times.

[☞ 5.5 Cleaning menu](#)

### 5.3.18 Start Feed menu

In the Start Feed menu, you can change the margin setting between images.

Setup Item	Setting	Description
Start Feed	-10 mm to <0 mm> to 500 mm	<ul style="list-style-type: none"> <li>Value over 0: The margin setting between images will be wider than when setting "0".</li> <li>Value equal to 0: The default margin setting between images will be applied.</li> <li>Value below 0: The margin setting between images will be smaller than when setting "0".</li> </ul>
	—	<ul style="list-style-type: none"> <li>[Enter] key: saves the setting and shifts to the previous menu.</li> <li>[Cancel] key: cancels the setting and shifts to the previous menu.</li> </ul> <a href="#">☞ 5.3 Setup menu</a>

#### NOTE

- With take-up system: if you want to set "Start Feed" to below 0, set "Page Gap" to "Narrow". If not, the Start Feed setting is not reflected properly.  
[☞ 5.3.2.1 Page Gap menu](#)
- The Start Feed function is executed from the second page printing when you select "Roll" in the "Rigid/Roll menu".  
[☞ 5.2.2.10 Rigid/Roll menu](#)

### 5.3.19 Initialization menu

Returns the settings of the printer to default.

Use this if you enter a wrong setting value by mistake, or if you want to set the value back to the default.

Setup item	Setting	Description
Initialization	ALL	All settings can be returned to factory default.
	Setup Menu	The setting of the Setup menu is returned to factory default.
	—	<ul style="list-style-type: none"> <li>[Enter] key: "Initializing" is displayed and the printer initializes the setting.</li> <li>[Cancel] key: shifts to the previous menu without initialization.</li> </ul> <a href="#">☞ 5.3 Setup menu</a>

### 5.3.20 Spitting menu

Sets up the spitting operation while printing.

#### NOTE

- When Spitting is set to “Off”, Nozzles will become easily clogged because spitting is not performed. In such a case, print quality cannot be guaranteed.
- When the spitting setting is “On Media”, the maximum printable media width becomes 16 mm shorter. Therefore, the side margins become the value that you have set in Side Margin menu +8 mm.
- The right side margin will be the following sum depending on the setting.  
Y of Origin menu + 8 mm (when the spitting is set to On Media) + Value set in Side Margin menu.

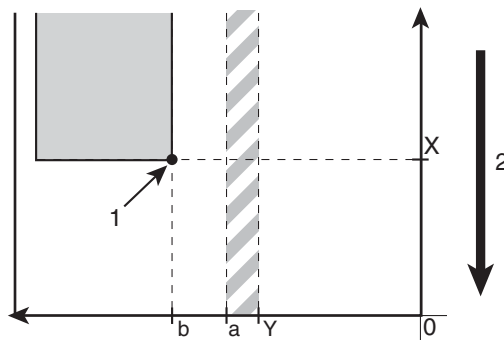

1. Print starting position
2. Media feed direction

X (media feeding distance)





Y (print head transferring distance)

a (0 mm/8 mm: Spitting setting is ON, Off/On Media)

b (5 mm to 25 mm: Side margin setting)

[☞ 5.3.1 Side Margin menu](#)

[☞ 5.3.4 Origin menu](#)

Setup item	Setting	Description
Spitting	<On>	<p>Every time Print head moves back and forth for the set number of times, Print head performs the spitting operation at Spitting box. Set the number of shuttles in “5.3.20.1 Pass Count menu”.</p> <ul style="list-style-type: none"> <li>[Enter] key: saves the setting and shifts to the sub menu.</li> </ul> <p> <a href="#">5.3.20.1 Pass Count menu</a></p>
	On Media	<p>Perform the spitting operation on the page margins. The printing speed will be improved since the number of time to return to Spitting box is reduced.</p> <ul style="list-style-type: none"> <li>[Enter] key: saves the setting and shifts to the sub menu.</li> </ul> <p> <a href="#">5.3.20.1 Pass Count menu</a></p>
	Off	<p>Spitting operation is not performed.</p> <ul style="list-style-type: none"> <li>[Enter] key: saves the setting and shifts to the previous menu.</li> </ul> <p> <a href="#">5.3 Setup menu</a></p>
	—	<ul style="list-style-type: none"> <li>[Cancel] key: cancels the setting and shifts to the previous menu.</li> </ul> <p> <a href="#">5.3 Setup menu</a></p>

### 5.3.20.1 Pass Count menu

Set the intervals that Print head returns to Spitting boxes when “On” or “On Media” is set in Spitting menu. Print head returns to Spitting box every shuttle per the set number.

#### NOTE

If the number of spitting returns is set high, the spitting operation is not done on Spitting box. Therefore there is a higher chance of nozzle clogging when printing for a long time. In such a case, print quality cannot be guaranteed.

Setup item	Setting	Description
Pass Count	<1 time> to 999 times	Set the spitting return count.
	—	<ul style="list-style-type: none"> <li>• [Enter] key: saves the setting and shifts to the previous menu.</li> <li>• [Cancel] key: cancels the setting and shifts to the previous menu.</li> </ul> <a href="#">🔗 5.3.20 Spitting menu</a>

### Example of spitting operation

Spitting setting	Return Count setting	Operation
On	1 time	Print head performs the spitting operation on Flushing box every time Print head returns to the origin position. Spitting operation is not performed over the media.
On	5 times	Performs the spitting operation on Flushing box on the origin side every five times Print head returns to the origin position. Spitting operation is not performed over the media.
On Media	1 time	Performs the spitting operation on Flushing box on the origin side every time Print head returns to the origin position. Performs the spitting operation on the media every time Print head returns to the origin position.
On Media	5 times	Performs the spitting operation on Flushing box on the origin side every five times Print head returns to the origin position. Performs the spitting operation on the media every time Print head returns to the origin position.
Off	—	Spitting is not performed on Spitting box or the media.

## 5.4 TestPrint Menu

Performs nozzle check of the print head and setup list.

### NOTE

- When “Banner 1” is set in the Print Mode menu, “PalettePrint” is not displayed.  
[☞ 5.2.2.1 Print mode menu](#)
- When using the 4-color set, the item for “Nozzle check B” is not displayed.

### TIP

Refer to the following for the operation procedure of test print.

[☞ 5.4 TestPrint Menu](#)

Setup item	Description
Nozzle check	Perform the nozzle check printing. It is used to check whether there are any clogged heads, or missing or blurred prints. <a href="#">☞ 3.6.1 Nozzle check</a>
Nozzle check B	Performs nozzle check printing for white ink. <a href="#">☞ 3.6.2 Nozzle check B</a>
Mode print	Mode print can be performed. Used to confirm the following printing conditions. <ul style="list-style-type: none"> <li>• Print quality</li> <li>• Effect</li> <li>• Adjustment value</li> </ul> <a href="#">☞ 3.6.3 Mode print</a>
Setup List	Setup list printing is performed. Use it for checking the setup item of the printer. <a href="#">☞ 3.6.4 Setup print</a>
Palette	Palette printing is performed. It is used to compare pen colors of the computer the colors printed by this printer. <a href="#">☞ 3.6.5 Palette print</a>
—	<ul style="list-style-type: none"> <li>• [Enter] key: “Printing” is displayed and test printing starts.</li> <li>• [Cancel] key: shifts to the previous menu.</li> </ul> <a href="#">☞ 5 Panel setup menu</a>

## 5.5 Cleaning menu

Perform Head cleaning.

**TIP**

Head cleaning can be operated when the printer is Normal.  
Refer to the following for operation procedures.

 [6.5.2 Head cleaning](#)

Setup item	Description
Short	Discharges smaller amount of ink compare to “Normal”. <ul style="list-style-type: none"> <li>• [Enter] key: “Cleaning ***” is displayed and Head cleaning starts. Progress on the Head cleaning is displayed in %.</li> </ul>
Normal	Select this mode normally. <ul style="list-style-type: none"> <li>• [Enter] key: “Cleaning ***” is displayed and Head cleaning starts. Progress on the Head cleaning is displayed in %.</li> </ul>
Long	Discharges larger amount of ink compare to “Normal”. Used when the print head does not improve by normal Head cleaning. <ul style="list-style-type: none"> <li>• [Enter] key: “Cleaning ***” is displayed and Head cleaning starts. Progress on the Head cleaning is displayed in %.</li> </ul>
Little Charge	Consumes a lot larger amount of ink than “Long”. <ul style="list-style-type: none"> <li>• The cleaning effect is much higher than “Long”.</li> <li>• [Enter] key: “Ink Refill ***” is displayed and ink charging starts. Progress on Little charge is displayed in %.</li> </ul>
Initial Charge	Initial ink charge. <ul style="list-style-type: none"> <li>• Performs the initial ink charge.</li> <li>• Consumes a lot larger amount of ink than “Little charge”.</li> <li>• The cleaning effect is much higher than “Little charge”.</li> <li>• [Enter] key: “Ink Refill ***” is displayed and initial ink charge starts. Progress on the initial ink charge is displayed in %.</li> </ul>
—	<ul style="list-style-type: none"> <li>• [Cancel] key: shifts to the previous menu.</li> </ul> <p> <a href="#">5 Panel setup menu</a></p>

## 5.6 Menu Option menu

Sets up the contents of the Setup menu.

You can make setup items that you do not normally use invisible.

Switch the setting “On (displayed)” to “Off (undisplayed)” using the [<] key or [>] key.

When the setting is “On”, “\*” is displayed.

### NOTE

Even if you select “Off” in the Menu option menu, you can display the settings temporarily by selecting “Temporary” in the Setup menu.

 [5.3 Setup menu](#)

Setup item	Setting	Description
Side Margin	<On>	Sets up whether to display the Side Margin menu.
	Off	
Take-up	<On>	Sets up whether to display the Take-up menu.
	Off	
Media Location	<On>	Sets up whether to display the Media Location menu.
	Off	
Origin	<On>	Sets up whether to display the Origin menu.
	Off	
Head Travel	<On>	Sets up whether to display the Head Travel menu.
	Off	
Multi Strike	<On>	Sets up whether to display the Multi Strike menu.
	Off	
Slant Check	<On>	Sets up whether to display the Slant Check menu.
	Off	
Auto Cleaning	<On>	Sets up whether to display the Auto Cleaning menu.
	Off	
Roll Length	<On>	Sets up whether to display the Roll Length menu.
	Off	
FrontInterlace	<On>	Sets up whether to display the FrontInterlace menu.
	Off	
BottomInterlace	<On>	Sets up whether to display the BottomInterlace menu.
	Off	
CR Maintenance	<On>	Sets up whether to display the CR Maintenance menu.
	Off	
Ink Status	<On>	Sets up whether to display the Ink Status menu.
	Off	



Setup item	Setting	Description
Life Times	<On>	Sets up whether to display the Life Times menu.
	Off	
Header Dump	<On>	Sets up whether to display the Header Dump menu.
	Off	
Exhaust Fan	<On>	Sets up whether to display the Exhaust Fan menu.
	Off	
White Maintenance	<On>	Set whether to display the White Maintenance menu.
	Off	
Start Feed	<On>	Sets up whether to display the Start Feed menu.
	Off	
Initialization	<On>	Sets up whether to display the Initialization menu.
	Off	
Spitting	On	Sets up whether to display the Spitting menu.
	<Off>	
ALL On		Displays all items in the Setup menu. <ul style="list-style-type: none"> <li>Pressing the [Enter] key displays “*” for all items in the Menu option menu.</li> </ul>
ALL Off		No items in the Setup menu are displayed. <ul style="list-style-type: none"> <li>Pressing the [Enter] key deletes “*” for all items in the Menu option menu.</li> <li>Even if you select “ALL Off”, you can display the items temporarily by selecting “Temporary” in the Setup menu.</li> </ul>
—		<ul style="list-style-type: none"> <li>[Cancel] key: saves the setting and shifts to the previous menu.</li> </ul>  <a href="#">5 Panel setup menu</a>

## 5.7 Maintenance menu

Performs ink discharge and maintenance of the adapter's plug in high-capacity pack adapter.

Setup item	Setting	Description
Maintenance	Daily Maintenance	Use this menu in following cases: <ul style="list-style-type: none"> <li>• If the nozzle missing still persists after performing head cleaning.</li> <li>• If you perform printing all day without entering to sleep mode and you need to perform daily maintenance.</li> </ul> ☞ 5.7.1 Daily Maintenance menu
	Plug Life	Check and initialize the lifetime counter of the adapter's plug in high-capacity pack adapter. ☞ 5.7.2 Plug Life menu
	Ink Discharge	Discharges the ink in the printer. This operation is performed before moving the printer. ☞ 5.7.3 Ink Discharge menu
	—	<ul style="list-style-type: none"> <li>• [Cancel] key: cancels the setting and shifts to the previous menu.</li> </ul> ☞ 5 Panel setup menu

### 5.7.1 Daily Maintenance menu

Use this menu to perform Daily Maintenance in following cases:

- If the nozzle missing still persists after performing head cleaning.
- If you perform printing all day without entering to sleep mode and you need to perform daily maintenance.

#### NOTE

To perform daily maintenance after using the printer for the day, go to “Menu1: Sleep Mode>”.

☞ 3.3.1 Set sleep mode on the printer

Setup item	Setting	Description
Daily Maint.	Start	Press the [Enter] key to start maintenance.
	End	After the maintenance is complete, press the [Enter] key. <ul style="list-style-type: none"> <li>• The printer automatically performs the “Short” cleaning.</li> </ul>
	—	<ul style="list-style-type: none"> <li>• [Cancel] key: shifts to the previous menu.</li> </ul> ☞ 5.7 Maintenance menu

## 5.7.2 Plug Life menu

Check and initialize the lifetime counter of the adapter's plug in high-capacity pack adapter.

Setup item	Setting	Description
Plug Life	Confirm	Check the adapter's plug lifetime counter. ☞ 5.7.2.1 Plug Life confirmation menu
	Init.	Initialize the adapter's plug lifetime counter. ☞ 5.7.2.2 Plug Life initialization menu
	—	<ul style="list-style-type: none"> <li>[Cancel] key: cancels the setting and shifts to the previous menu.</li> </ul> ☞ 5.7 Maintenance menu

### 5.7.2.1 Plug Life confirmation menu

Setup item	Setting	Description
Confirm	Slot1 to Slot6	Check each adapter's plug lifetime counter. [Enter] key: displays the lifetime counter for each slot. [*]: the number of [*] shows the adapter's plug lifetime. If it reaches the end of its lifetime, "Change" will appear.
	—	<ul style="list-style-type: none"> <li>[Cancel] key: cancels the setting and shifts to the previous menu.</li> </ul> ☞ 5.7.2 Plug Life menu

### 5.7.2.2 Plug Life initialization menu

Setup item	Setting	Description
Init.	Slot1 to Slot6	Initialize each adapter's plug lifetime counter. [Enter] key: initializes the selected lifetime counter. Press [Enter] to reset the counter in the confirmation message.
	—	<ul style="list-style-type: none"> <li>[Cancel] key: cancels the setting and shifts to the previous menu.</li> </ul> ☞ 5.7.2 Plug Life menu

### 5.7.3 Ink Discharge menu

Performs head washing using cleaning fluid.

Setup item	Setting	Description
Ink Discharge	Start	<ul style="list-style-type: none"> <li>• [Enter] key: Performs head cleaning.</li> </ul>
	Empty WasteInk ->E	Check Waste fluid tank, and remove any waste fluid from the tank. <ul style="list-style-type: none"> <li>• [Enter] key: shifts to the next procedure.</li> </ul>
	Remove Cartridges	Remove all cleaning cartridges.
	Busy-Washing	Discharging the cleaning liquid from Print head.
	[ALL] No cartridges	Cleaning is complete.
	—	<ul style="list-style-type: none"> <li>• [Cancel] key: shifts to the previous menu without Head washing.</li> </ul>

## 5.8 Version menu

Displays the versions of the firmware.

This is to be used by a service person during maintenance.

Setup item	Setting	Description
Ver. M	*.**	Displays the versions of the firmware.
	—	<ul style="list-style-type: none"> <li>• [Cancel] key: shifts to the previous menu.</li> </ul>  5 Panel setup menu

## 5.9 Initial menu

Display language or unit for LCD is configured. IP addresses are also configured.

Setup item	Setting	Description
Initial	Language	Sets the language used in the menu items displayed on LCD monitor of Operation panel. ☞ 5.9.1 Language menu
	Length	Displays the length in centimeters or inches. ☞ 5.9.2 Length menu
	IP Address	Sets the IP address of the printer. ☞ 5.9.3 IP Address menu
	Subnet Mask	Sets the subnet mask of the printer. ☞ 5.9.4 Subnet Mask menu
	Gateway	Sets the gateway. ☞ 5.9.5 Gateway menu
	Alert Buzzer	Selects how to turn off the printer beep sound. ☞ 5.9.6 Alert Buzzer menu
	—	<ul style="list-style-type: none"> <li>• [Enter] key: shifts to the sub menu.</li> <li>• [Cancel] key: cancels the setting and shifts to the previous menu.</li> </ul> ☞ 5 Panel setup menu

### 5.9.1 Language menu

Sets the language used in the menu items displayed on LCD monitor of Operation panel.

Setup item	Setting	Description
Language	<エイゴ English>	Displays the menu items in English.
	ニホンゴ Japanese	Displays the menu items in Japanese.
	—	<ul style="list-style-type: none"> <li>• [Enter] key: saves the setting and shifts to the previous menu.</li> <li>• [Cancel] key: cancels the setting and shifts to the previous menu.</li> </ul> ☞ 5.9 Initial menu

## 5.9.2 Length menu

Sets the unit to display the length.

Setup item	Setting	Description
Length	<mm>	Displays the length in millimeters (mm).
	inch	Displays the length in inches (inch).
	—	<ul style="list-style-type: none"> <li>• [Enter] key: saves the setting and shifts to the previous menu.</li> <li>• [Cancel] key: cancels the setting and shifts to the previous menu.</li> </ul>  <a href="#">5.9 Initial menu</a>

## 5.9.3 IP Address menu

Sets the IP address of the printer.

Use this menu when using printer connecting the network.

### NOTE

Be sure to set the IP address after consulting the network administrator.

Setup item	Setting	Description
IP Address	0.0.0.0 to <192.168.1.253> to 255.255.255.255	Change the IP address by operating the following keys. <ul style="list-style-type: none"> <li>• [+] key: increases the setting value.</li> <li>• [-] key: decreases the setting value.</li> <li>• [Enter] key: changes the setting for the next segment.</li> </ul>
	—	<ul style="list-style-type: none"> <li>• [Cancel] key: cancels the setting and shifts to the previous menu.</li> </ul>  <a href="#">5.9 Initial menu</a>

## 5.9.4 Subnet Mask menu

Sets the subnet mask of the printer.

Use this menu when using printer connecting the network.

### NOTE

Be sure to set the subnet mask after consulting the network administrator.

Setup item	Setting	Description
Subnet Mask	0.0.0.0 to <255.255.255.0> to 255.255.255.255	Change the subnet mask by operating the following keys. <ul style="list-style-type: none"> <li>• [+] key: increases the setting value.</li> <li>• [-] key: decreases the setting value.</li> <li>• [Enter] key: changes the setting for the next segment.</li> </ul>
	—	<ul style="list-style-type: none"> <li>• [Cancel] key: cancels the setting and shifts to the previous menu.</li> </ul> <a href="#">🔑 5.9 Initial menu</a>

## 5.9.5 Gateway menu

Sets the gateway.

Use this menu when using printer connecting the network.

### NOTE

Be sure to set the gateway after consulting the network administrator.

Setup item	Setting	Description
Gateway	0.0.0.0 to <192.168.1.254> to 255.255.255.255	Change the gateway by operating the following keys. <ul style="list-style-type: none"> <li>• [+] key: increases the setting value.</li> <li>• [-] key: decreases the setting value.</li> <li>• [Enter] key: changes the setting for the next segment. Save the set values in the 4th segment and returns to the previous menu.</li> </ul>
	—	<ul style="list-style-type: none"> <li>• [Cancel] key: cancels the setting and shifts to the previous menu.</li> </ul> <a href="#">🔑 5.9 Initial menu</a>

## 5.9.6 Alert Buzzer menu

Selects how to turn off the printer beep sound when an error occurs.

For unattended printing, you can select Off setting to avoid continuous buzzer beep.

Setup Item	Description	Setup Item
Alert Buzzer	<On>	Press any key to turn off beep sound. This is initially setting.
	Off	After several beeps, the printer automatically turns off beep sound.
	—	<ul style="list-style-type: none"> <li>[Enter] key: saves the setting and shifts to the previous menu.</li> <li>[Cancel] key: cancels the setting and shifts to the previous menu.</li> </ul> <a href="#">☞ 5.9 Initial menu</a>

## 5.10 Job Status Menu

Various information of previous print will be displayed.

The length of printed data and if the print is completed will be displayed. When the print is canceled, the information how much the print is completed will be displayed.

Setup item	Setting	Description
Job Status	JobStatus	Displays if the print is completed. <ul style="list-style-type: none"> <li>When the print is completed: “Completed”</li> <li>When the print is canceled: “Canceled”</li> </ul>
	ToDoLength	The total length of print data (media feeding direction) will be displayed.
	Done	The printed length will be displayed.
	Remain	The remaining length of print data will be displayed.
	—	<ul style="list-style-type: none"> <li>[Cancel] key: cancels the setting and shifts to the previous menu.</li> </ul> <a href="#">☞ 5 Panel setup menu</a>

### TIP

- This function is to check the information of print data with the print operation is completed. For the details on data while printing, please refer to the below.
  - [☞ 4.4.4.2 Settings that can be changed or confirmed while printing](#)
  - [☞ 4.4.6 Normal Display while Printing](#)
- The values displayed in this function are just standard values, not guarantee the accuracy.
- If the print data includes no length data, all information will be displayed as “0”.



## 6 Maintenance

This chapter describes daily maintenance of the product.

## 6.1 Wearing the gloves and goggles

Skin or eye contact with UV curable ink may cause skin inflammation or allergic reaction. Wear protective gloves, goggles and/or face shield, and clothing while using of the printer.

Especially when performing any of the following operations, be sure to wear the supplied gloves (or solvent resistant gloves) and goggles.

- [6.2 Shaking ink cartridges](#)
- [6.4.1 Replacing ink cartridges](#)
- [6.4.3 Replacing the flushing-box sponges](#)
- 
- 
- 
- [6.6 Disposal the waste fluids](#)

### 6.1.1 How to wear the supplied gloves

Wear the rubber gloves (white) over the plastic gloves (pink).

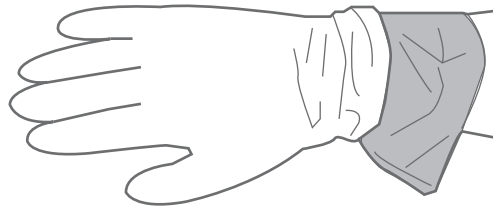

#### CAUTION

- Do not touch UV curable ink with bare hands prior to ink curing.
- If glove becomes contaminated with ink, replace it with new.
- If protective clothing becomes contaminated with ink, immediately remove and wash for re-use.
- If ink gets on skin, immediately wash with soap and plenty of water for 15 minutes. Seek medical advice/attention if irritation or inflammation are present.
- If ink gets in eyes, flush eyes with plenty of water for 15 minutes and seek medical advice/attention immediately.
- If swallowed, rinse mouth immediately and do not induce to vomiting. Seek medical advice/attention.

## 6.2 Shaking ink cartridges

To maintain color stability, you need to shake all ink cartridges before operation every day.

Also, when the following error message is displayed on Operation panel, shake the ink cartridge in the corresponding ink slot.

Six color set:

- “Shake W Cartridge”: Displayed every 12 hours. Shake the White (Wh) ink cartridge.
- “Shake KMCY Cartridge”: Displayed every 72 hours. Shake the Black (K), Magenta (M), Cyan (C), and Yellow (Y) ink cartridges.
- “Shake KMCYW Cartridge”: Shake the Black (K), Magenta (M), Cyan (C), Yellow (Y) and White (Wh) ink cartridges.

Four color set:

- “Shake ALL Cartridge”: Displayed every 72 hours. Shake the Black (K), Magenta (M), Cyan (C) and Yellow (Y) ink cartridges.

### CAUTION

- **Shake the ink cartridge before use.**
- **Shake the ink cartridges periodically.**  
**Otherwise, the ink inside the cartridges settles or coagulates and may cause poor print quality or a malfunction.**
- **If the message is displayed prompting you to shake the ink cartridge but you do not shake it for more than 12 hours, the printer does not perform printing. If this happens, shake the ink cartridge to enable printing.**

### NOTE

The contents in this section is the same as the “Precautions before using dedicated ink” sheet provided with the printer.

Follow the procedure below to shake ink cartridges.

1. Check that the printer is turned ON.
2. Wear the supplied gloves and remove ink cartridges from Ink cartridge slots.

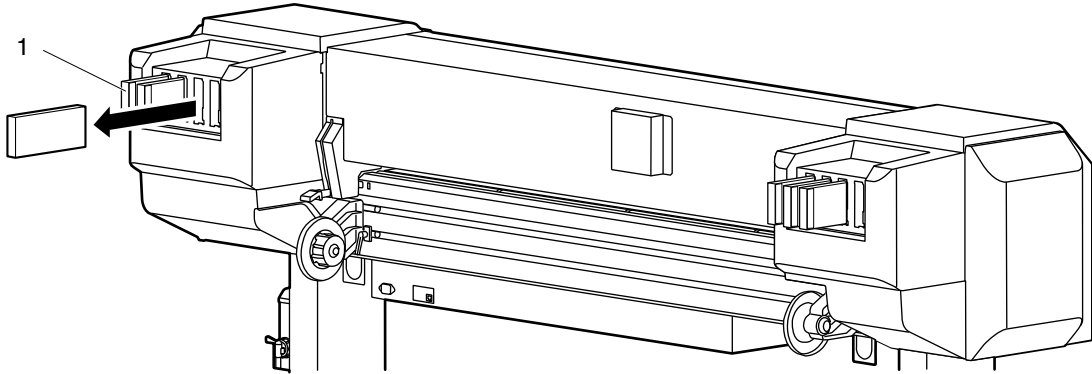

No.	Name
1	Ink cartridges

3. Using the paper towel provided with the printer to wipe off the ink attached to the printer plug of Ink cartridge.

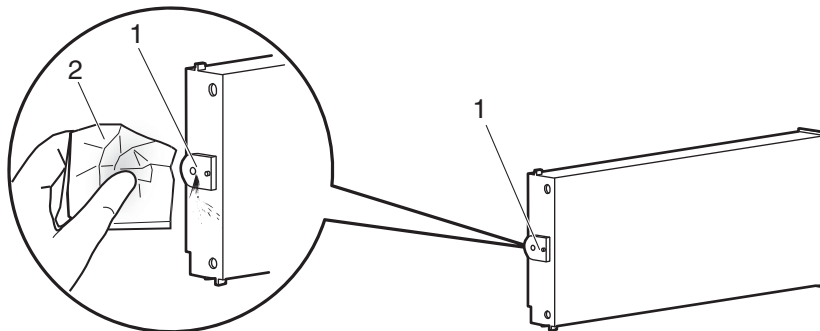

No.	Name
1	Printer plug
2	Paper towel

4. While holding the printer plug with a paper towel, shake the ink cartridge.
  - Turn the ink plug upward and wait for 3 seconds.
  - Next, turn the ink plug downward and wait for 3 seconds.
  - Repeat that 10 times.

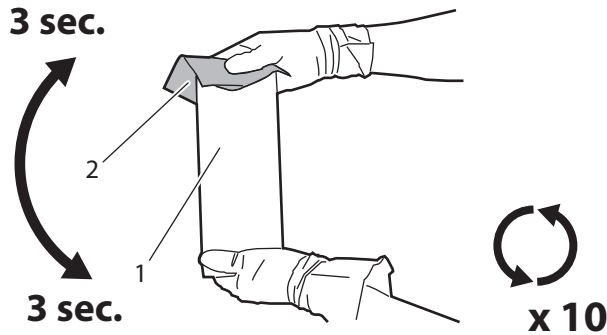

No.	Name
1	Ink cartridge
2	Paper towel

5. Re-insert the ink cartridges into Ink cartridge slots.

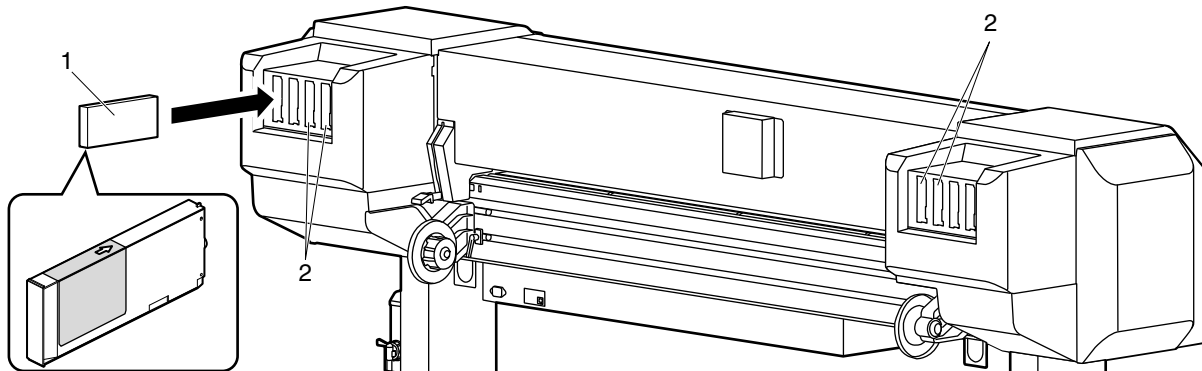

No.	Name
1	Ink cartridge
2	Ink cartridge slot

**NOTE**

Make sure you insert the ink cartridges into the original slots.  
 Even when you have the same color ink cartridges, do not switch and insert them into different slots.

## 6.3 Before using sleep mode for a long time

- Perform daily maintenance.



### CAUTION

---

- **To continue the sleep mode for one week or longer, when one week has passed, perform the following:**
    - **Check the ink level and replace the relevant ink cartridge if “InkNearEnd” is displayed.**
    - **Shake the ink cartridges.**
    - **Empty the waste fluid inside Waste fluid bottle.**
-

## 6.4 Replacing consumable components

This section describes when and how to replace the ink cartridges, roll media and flushing-box sponges.

### 6.4.1 Replacing ink cartridges



- **Store ink cartridges in a cool, dark place - avoid direct sunlight.**
- **After opening the aluminum package, put the cartridge back in the opened package to store. UV curable ink will cure gradually through exposure to ultraviolet light and may lead to printer malfunction.**
- **Do not disassemble the ink cartridges.**  
**If disassembled, there is a possibility that ink might come into contact with eyes or skin.**

#### (1) Replacement time

- a. When “[\*\*\*\*\*] InkNearEnd” is displayed on the operation panel
  - This message is displayed when there is a small amount of ink remaining in the ink cartridge.
  - The alarm buzzer sounds.  
To stop the buzzer, press the [Enter] key.
  - Replace with new ink cartridges.
- b. When “[\*\*\*\*\*] InkEnd” is displayed.
  - This message is displayed when there is no ink remaining in the ink cartridge.
  - Printing operation stops.
  - The alarm buzzer sounds.  
To stop the buzzer, press the [Enter] key.
  - Replace with new ink cartridges immediately.

**NOTE**

- [\*\*\*\*\*] in the messages for ink cartridge replacement indicates the color that is almost empty or running out, using the slot number.

<When using 6-color set>

- 1: Black (K)
- 2: Cyan (C)
- 3: Magenta (M)
- 4: Yellow (Y)
- 5: Varnish (VA)
- 6: White (WH)
- ALL: All ink

<When using 4-color set>

- 1: Magenta (M)
  - 2: Magenta (M)
  - 3: Cyan (C)
  - 4: Cyan (C)
  - 5: Black (K)
  - 6: Yellow (Y)
  - ALL: All ink
- If “Ink End” is displayed, printing operation is suspended even during printing.
  - If “Ink End” is displayed, you cannot print until inserting the new ink cartridge.
  - If there is no ink cartridge for replacement at hand, leave the empty ink cartridge inserted in the printer.  
Leaving the printer with the ink cartridge removed may cause the print head to clog.
-



## (2) Type

For details about ink cartridge, contact your local MUTOH dealer.

### NOTE

Use genuine ink cartridges for replacement.

This printer is designed to use genuine ink cartridges.

If you use an ink cartridge that is not a product of the original manufacturer,

- Printing might become blurred, or the end of the ink in the bag might not be detected correctly.
- Any problems caused by using an ink cartridge other than those recommended above will not be covered by the warranty, and repair expenses will be paid by the customer.

## (3) Replacing steps

Follow the procedure below to replace the ink cartridges.

### CAUTION

- **UV curable ink is harmful to skin; make sure you wear gloves when handling the ink cartridges so that the ink does not adhere to your skin. Wear safety goggle and protective clothing if necessary. Skin or eye contact with UV curable ink may cause skin inflammation or allergic reaction.**
- **If the ink adheres to your skin, wash with soap and a large amount of water immediately; consult a doctor if an abnormal symptom occurs.**
- **If the ink gets in your eyes, wash with a large amount of water and immediately see a doctor.**

### NOTE

- Do not give ink cartridges strong shakes.  
Doing so may cause ink leakage.
- Do not disassemble the ink cartridges.  
A disassembled ink cartridges cannot be used.
- When an ink cartridge is moved from a cold place to warm place, keep the ink cartridge for three hours or more in the new printing environment before printing.
- Do not refill an ink cartridge with ink.  
It may result in abnormal printing.

1. Confirm that the printer is turned ON.

**NOTE**

Do not replace ink cartridges when the printer is turned OFF.  
The remaining ink may not be detected correctly, causing abnormal printing.

2. Wear the supplied gloves and remove the ink cartridge from the ink slot.

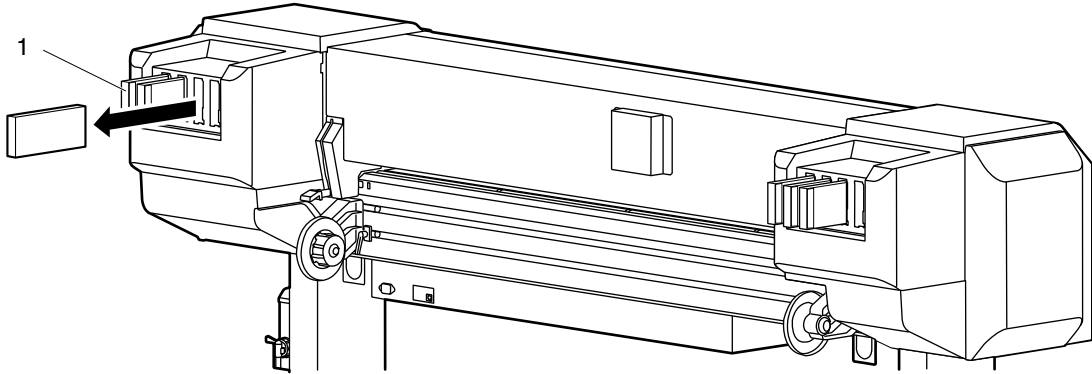

No.	Name
1	Ink cartridge

3. Shake new ink cartridges.
  - Turn the ink plug upward and wait for 3 seconds.
  - Next, turn the ink plug downward and wait for 3 seconds.
  - Repeat that 10 times.

**CAUTION**

- **Shake the ink cartridge before use.**
- **Shake the ink cartridges periodically.**  
**Otherwise, the ink inside the cartridges settles or coagulates and may cause poor print quality or a malfunction.**

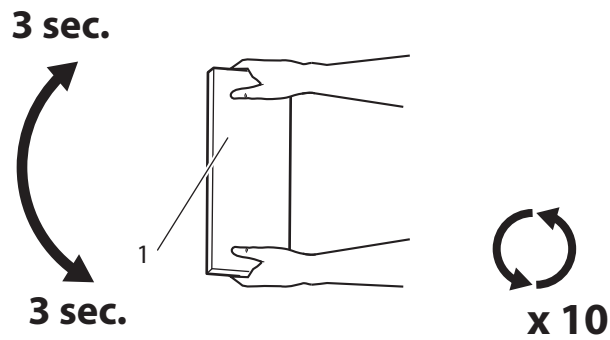

No.	Name
1	Ink cartridge

4. Insert the ink cartridges into Ink cartridge slots.
  - Insert the ink cartridges all the way in ink cartridge slots.

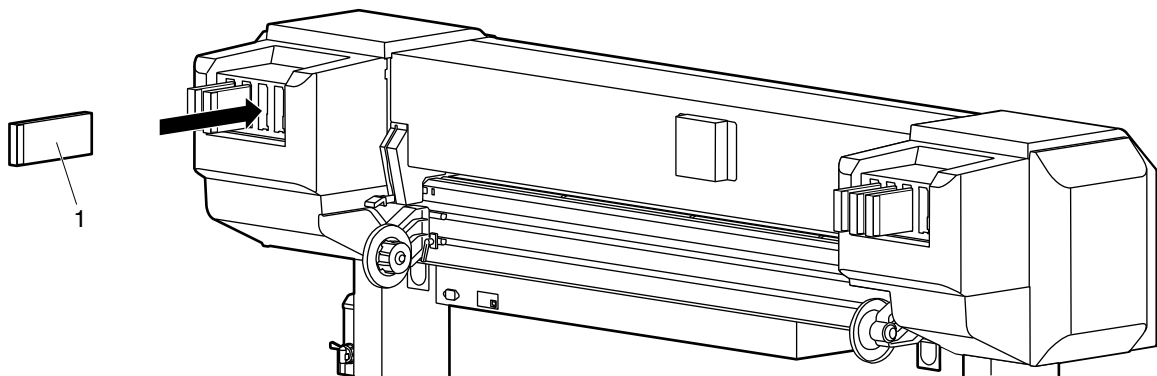

No.	Name
1	Ink cartridge

5. Confirm that Operation panel is back to the Normal condition.

**NOTE**

If ink cartridge is replaced during printing, printing resumes.

---

- Ink cartridge replacement is complete.

## 6.4.2 Replacing roll media

This sub-section describes when and how to replace roll media.

### (1) Replacement time

Replace roll media in the following situations.

- a. When the roll media loaded in the printer runs out
  - “End Of Roll” is displayed.
  - If media runs out during printing, the printer stops printing.
- b. When you want to change the media type to use

### (2) Type

**TIP**

For types and details of roll media, refer to “8.3 Options/Supply list”.

### (3) Replacing steps

Follow the procedure below to replace roll media.

1. If the printer is turned ON, confirm that operation such as printing is not in progress.
2. Raise Front media loading lever (lower Rear media loading lever).

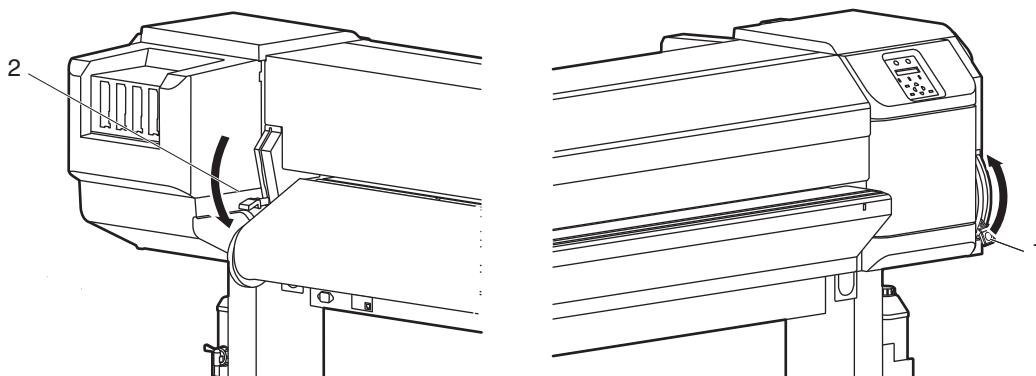

No.	Name
1	Media loading lever
2	Rear media loading lever

3. Turn the flanges of the roll media holders and take up roll media.

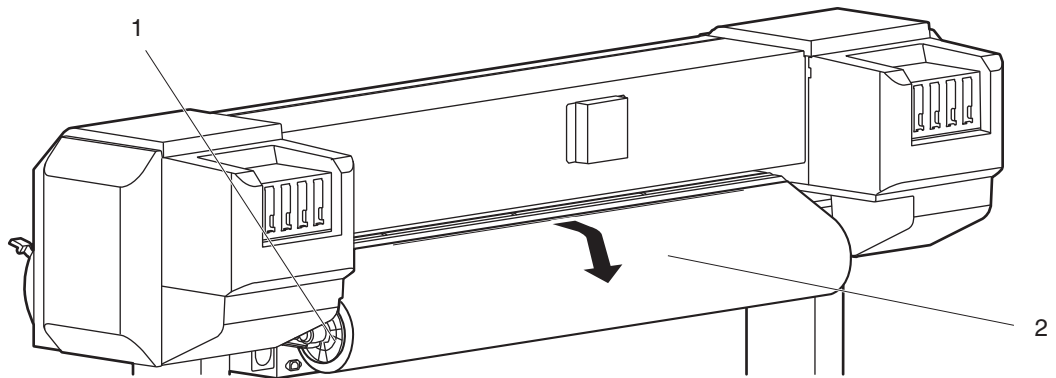

No.	Name
1	Flanges
2	Roll media

4. Loosen the lever of the right roll media holder and remove the media.

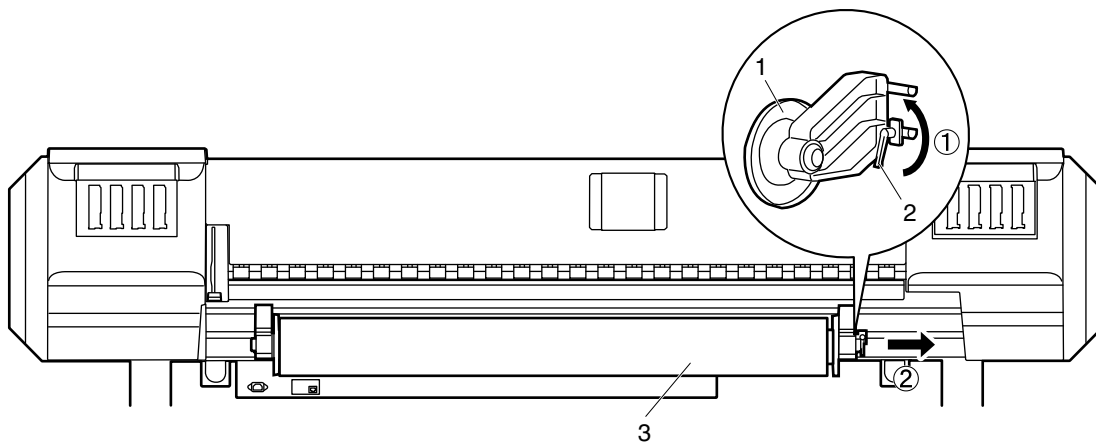

No.	Name
1	Roll media holder (Right)
2	Fixing lever
3	Roll media

5. Take the same procedure as in step 4, remove the roll media from the left roll media holder.

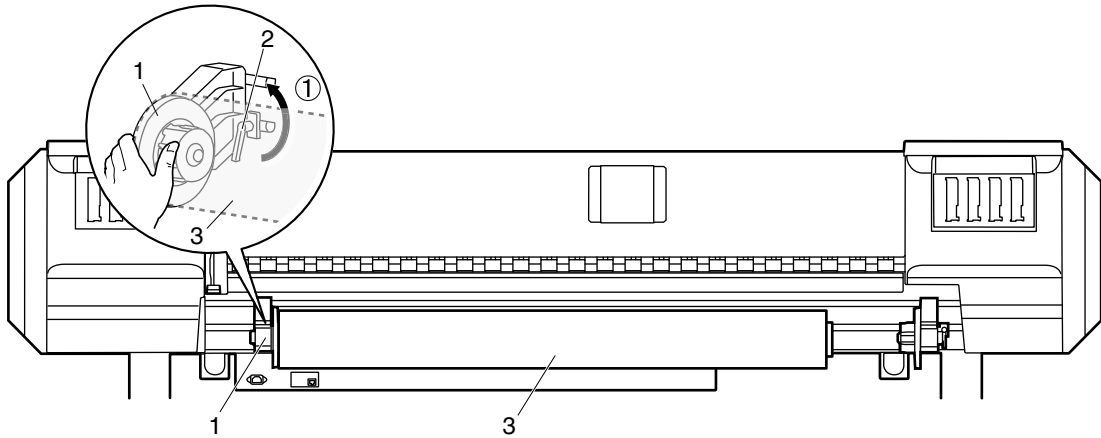

No.	Name
1	Roll media holder (Left)
2	Fixing lever
3	Roll media

6. To load another roll media, refer to the following.

**TIP**

- For loading roll media, refer to “[3.5 Setting media](#)”.
- For storing roll media not in use, refer to “[4.2.3 Precaution on storing media](#)”.

- Roll media replacement is complete.

### 6.4.3 Replacing the flushing-box sponges

This section explains how to replace the flushing-box sponges.

#### NOTE

Make sure to install the flushing-box sponges in the printer.  
The flushing-box sponges are an essential part to make printing consistent.

#### (1) Replacement time

Replace the flushing-box sponges in the following situations.

- When ink clumps have accumulated on the flushing-box sponges beyond the flushing-box frame.

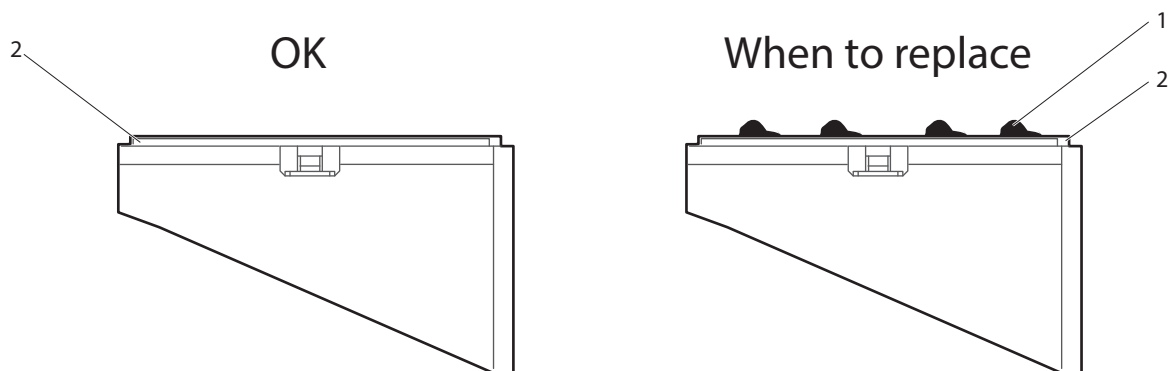

No.	Name
1	Ink clump
2	Flushing-box frame

#### (2) Type

#### TIP

For types and details of the flushing-box sponge, contact your local MUTOH dealer.



### (3) Replacing steps

Follow the steps below to replace the flushing-box sponges.



- Ink and waste fluid are harmful to skin. During this operation, wear the supplied gloves and make sure that ink does not adhere to your skin. Wear safety goggle and protective clothing if necessary.  
Skin or eye contact with UV curable ink may cause skin inflammation or allergic reaction.
- If the ink adheres to your skin, wash with soap and a large amount of water immediately; consult a doctor if an abnormal symptom occurs.
- If the ink gets in your eyes, wash with a large amount of water and immediately see a doctor.

1. Check the followings while the printer is turned ON.
  - Printing or other operations are not in progress.
  - Operation panel display is Normal.
2. Display the CR Maintenance menu.
  - a. Press the [Menu] key.

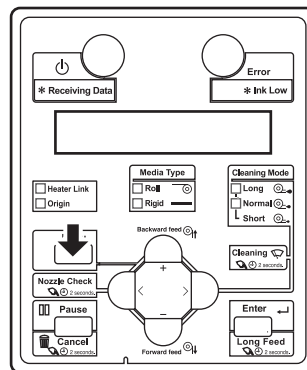

- “Menu 1: Sleep Mode>” is displayed.

- b. Press the [+] or [-] key to select “Menu3: Setup>”.

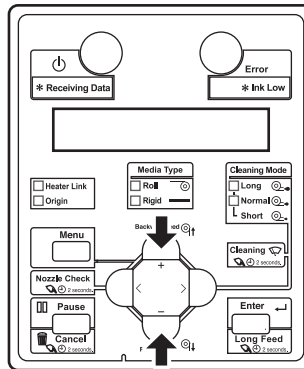

- c. Press the [>] key.

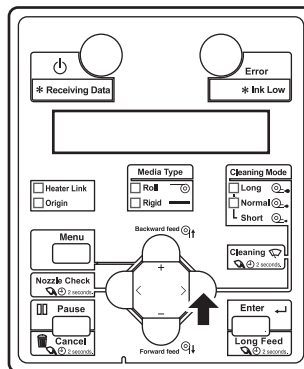

- “Set1: Side Margin” is displayed.

- d. Press the [+] key or [-] key to select “Set12: CR Maintenance”.

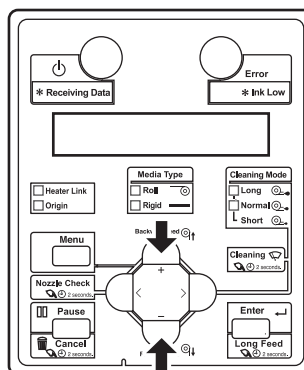

e. Press the [Enter] key.

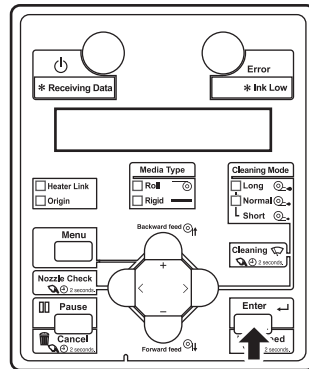

- “CR Mainte.: Start” is displayed.
- The display enters the CR Maintenance menu.

[5.3.12 CR Maintenance menu](#)

3. Press the [Enter] key.

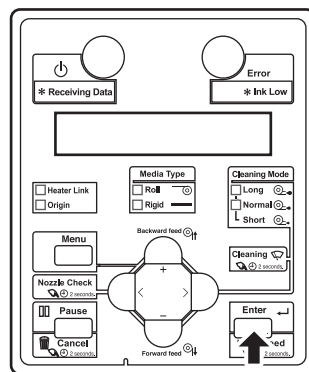

- Maintenance starts.
- The print head moves to the left.
- “CR Mainte.: End” is displayed.

4. Open the front cover.

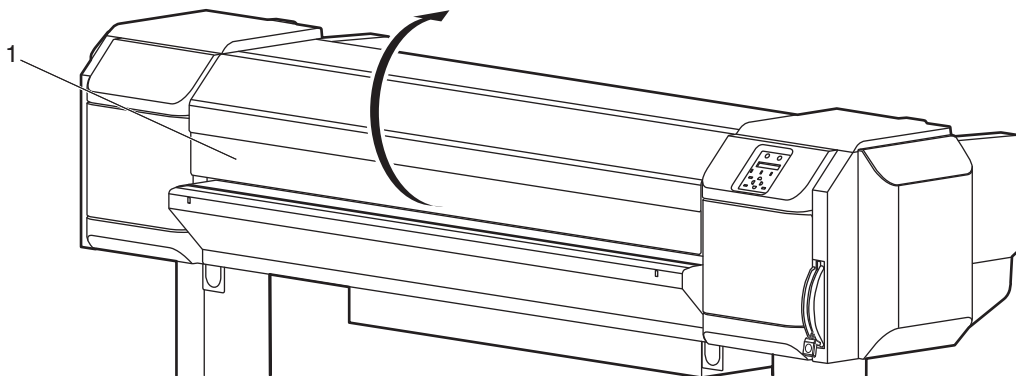

No.	Name
1	Front cover

5. Open Maintenance cover on the right side of the printer.

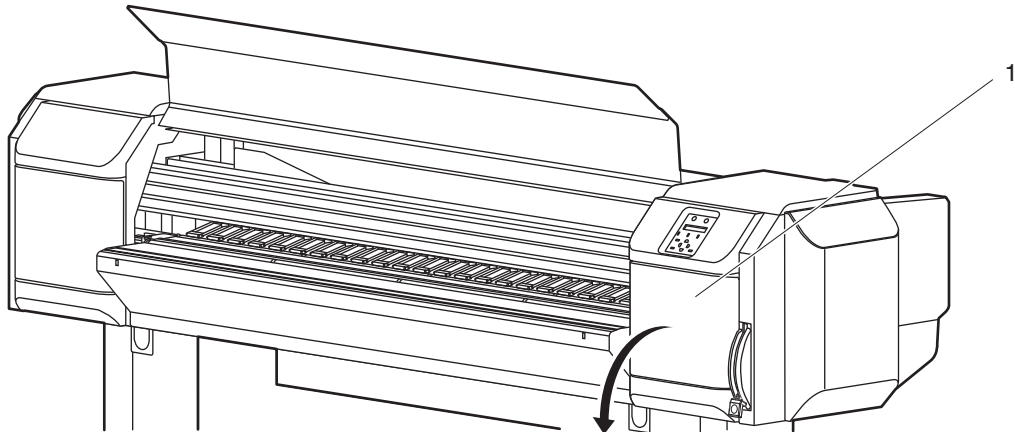

No.	Name
1	Maintenance cover

6. Insert your left hand from the front cover side. While holding the flushing box from above, lift the flushing-box sponge hook and release the hook. Then, remove the flushing-box sponge holder.

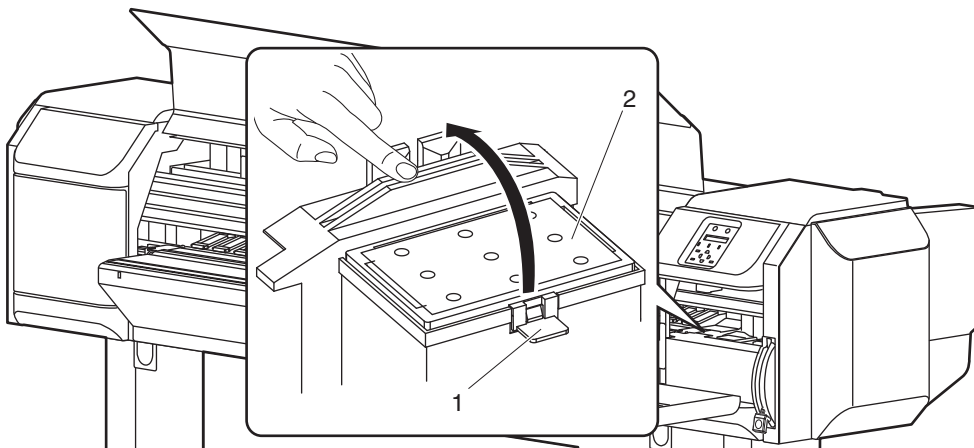

No.	Name
1	Flushing-box sponge hook
2	Flushing-box sponge holder

**CAUTION**

- Do not drop waste fluid when replacing the flushing-box sponges. If waste fluid comes into contact with the grid roller, the surface of the grid roller will be damaged, and the media feed function may be affected.

7. Install the new flushing-box sponge holders to each flushing box.

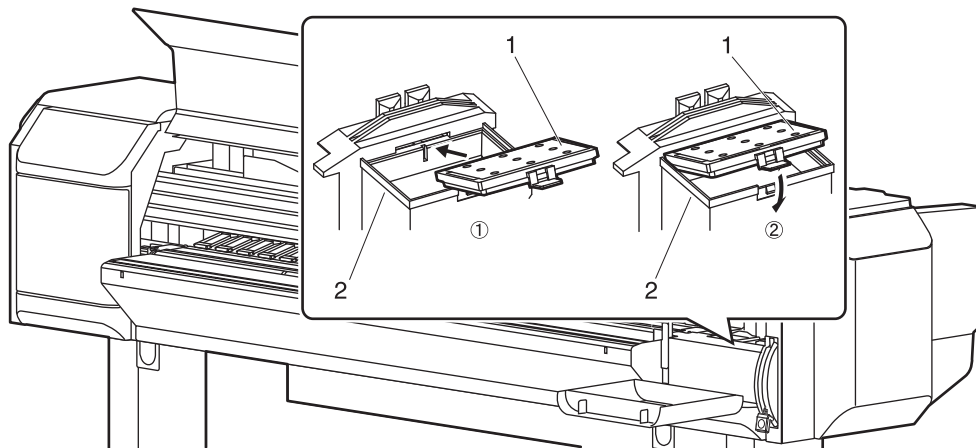

No.	Name
1	Flushing-box sponge holder
2	Flushing boxes

8. Close the maintenance cover.

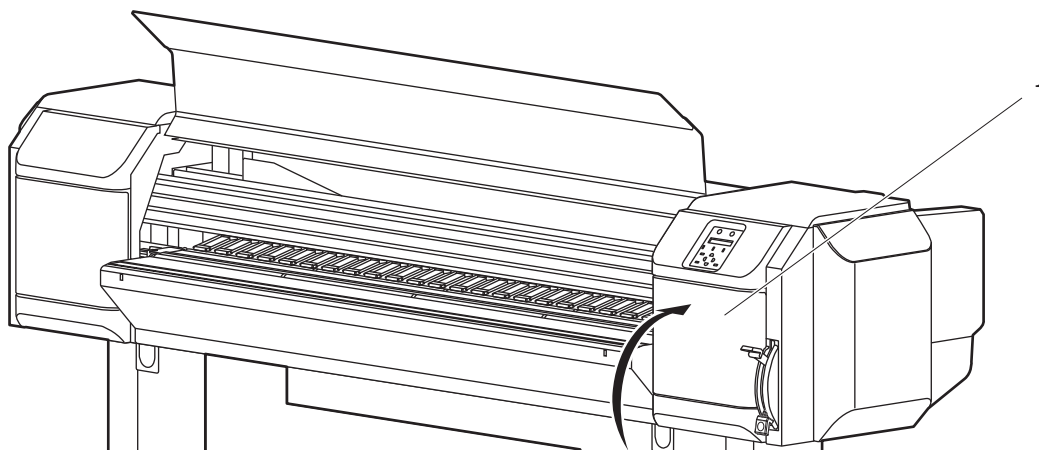

No.	Name
1	Maintenance cover

9. Close the front cover.

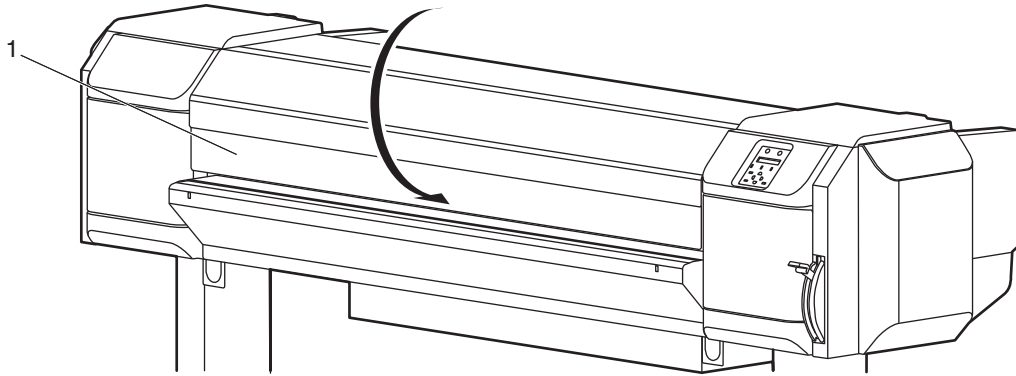

No.	Name
1	Front cover

10. Press the [Enter] key.

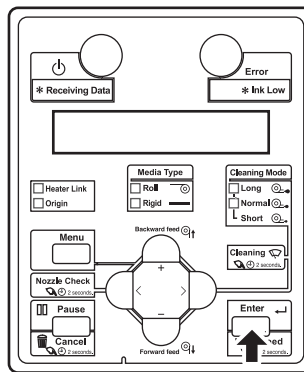

- The print head returns to its original position.
- “CR Mainte.: Start” is displayed.

11. Press the [Cancel] key several times.

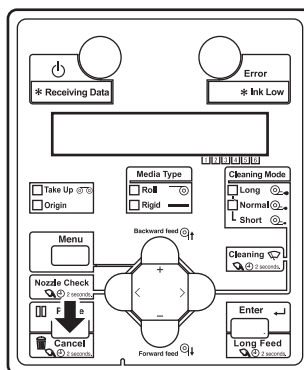

- The printer enters Normal.
- This completes the replacement procedure of Absorber for Flushing box.

## 6.4.4 Replacing the cleaning wiper

This section explains how to replace the cleaning wiper.

### NOTE

Make sure to install the cleaning wiper in the printer.  
The cleaning wiper is an essential part to make printing consistent.

### (1) Replacement time

Every six months

### (2) Type

### TIP

For types and details of the cleaning wiper, contact your local MUTOH dealer.

### (3) Replacing steps

Follow the steps below to replace the cleaning wiper.

### CAUTION

- **For this operation, be sure to wear the supplied gloves (or solvent resistant gloves) and goggles to prevent ink from contacting your eyes or skin.**
- **Skin or eye contact with UV curable ink may cause skin inflammation or allergic reaction.**
  - **If ink gets on skin, immediately wash with soap and plenty of water for 15 minutes. Seek medical advice/attention if irritation or inflammation are present.**
  - **If ink gets in eyes, flush eyes with plenty of water for 15 minutes and seek medical advice/attention immediately.**

1. Check the followings while the printer is turned ON.

- Printing or other operations are not in progress.
- Operation panel display is Normal.

2. Display the CR Maintenance menu on the operation panel.

a. Press the [Menu] key.

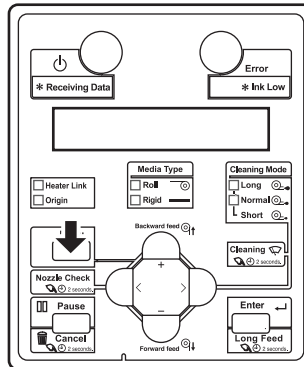

- “Menu 1: Sleep Mode>” is displayed.

b. Press the [+] or [-] key to select “Menu3: Setup>”.

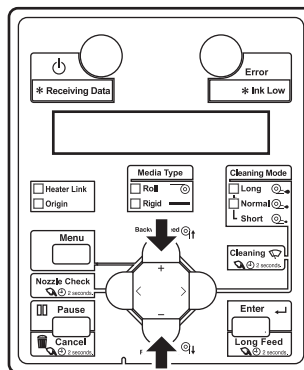

c. Press the [>] key.

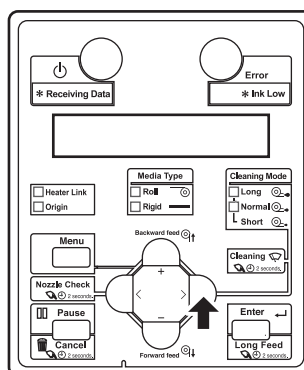

- “Set1: Side Margin” is displayed.



- d. Press the [+] key or [-] key to select “Set12: CR Maintenance”.

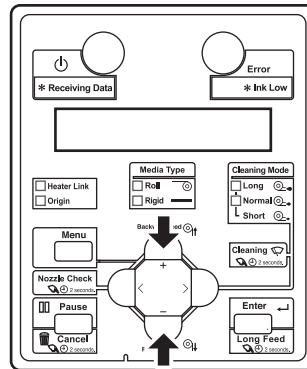

- e. Press the [Enter] key.

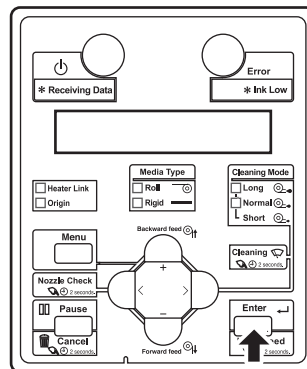

- “CR Mainte.: Start” is displayed.
- The display enters the CR Maintenance menu.

[5.3.12 CR Maintenance menu](#)

3. Press the [Enter] key.

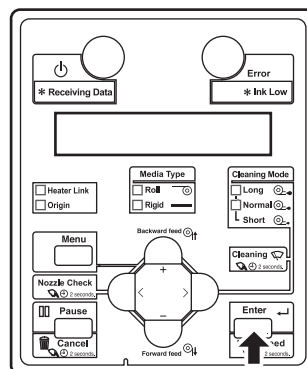

- Maintenance starts.
- The print head moves to the left.
- “CR Mainte.: End” is displayed.

4. Open Maintenance cover on the right side of the printer.

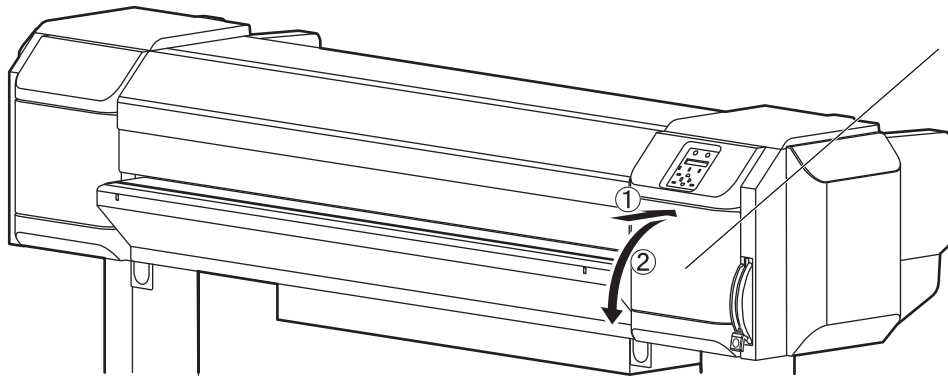

No.	Name
1	Maintenance cover

5. Lift the cleaning wiper hook and release the hook. Then, remove the cleaning wiper.

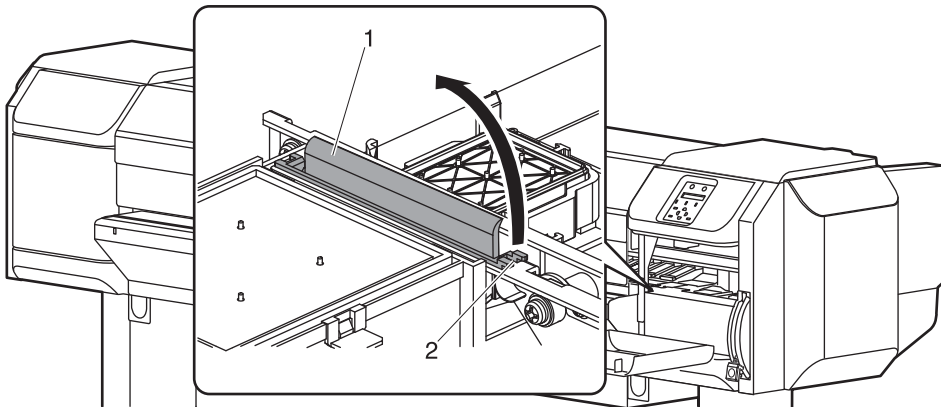

No.	Name
1	Cleaning wiper
2	Cleaning wiper hook

6. Follow the steps below to install new cleaning wiper.
- Slide the rear side of the new cleaning wiper into its slot.
  - Press the wiper hook down until it clicks into place.

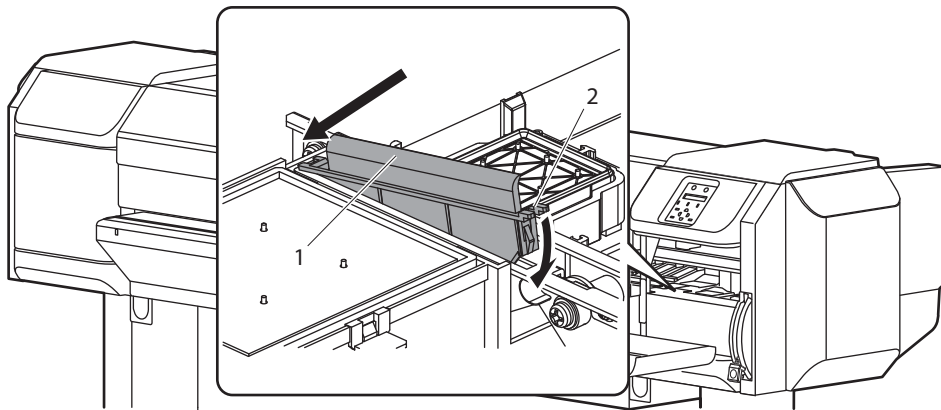

No.	Name
1	Cleaning wiper
2	Cleaning wiper hook

7. Close the maintenance cover.

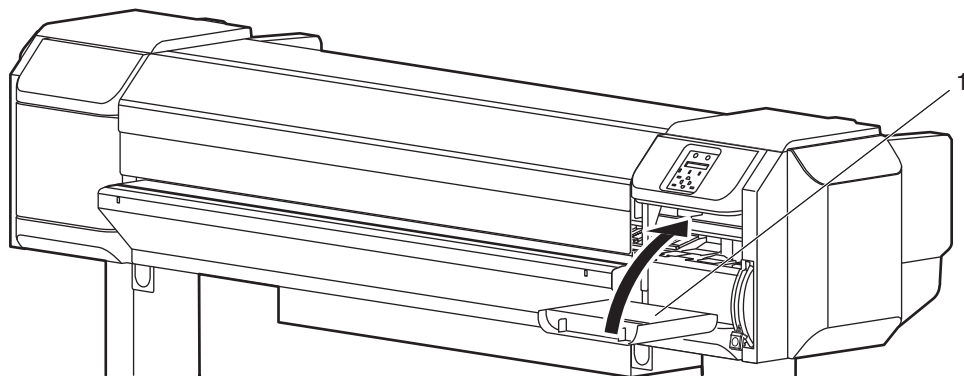

No.	Name
1	Maintenance cover

- f. Press the [Enter] key.

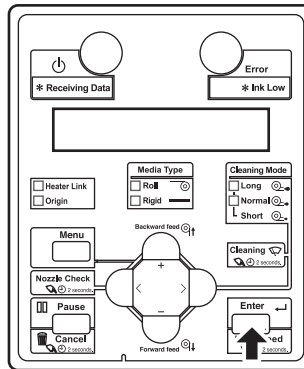

- The print head returns to its original position.
- “CR Maint.: Start” is displayed on the operation panel.

8. Press the [Cancel] key several times.

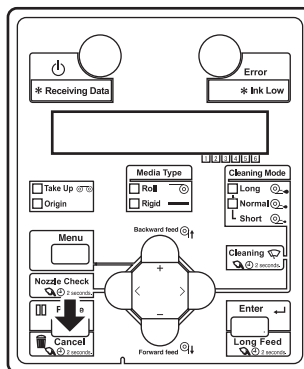

- The printer enters Normal.
- This completes the replacement procedure of Absorber for Flushing box.

## 6.4.5 Replacing the Adapter's plug in High-capacity ink pack adapter

When the high-capacity ink pack adapter is inserted/removed in a certain number of times, the adapter's plug should be replaced.

If it reaches the end of its lifetime, "[\*] Change Plug" appears on the panel (\*: displays the slot number to be replaced).

The message can be cancelled by pressing any key, however the message will always appear after printing until the replacement is completed.

For the replacement procedures, see "3.3 Replacing Adapter's plug" in high-capacity ink pack adapter operation manual.

When inserting the replaced adapter, the following message appears:

"[\*] Plug Changed? No"

Choose "Yes" by pressing [+]/[-] keys and press Enter. The adapter's plug lifetime counter will be reset.

### NOTE

- "[\*] Plug Changed? No" appears by simply inserting/removing the adapter regardless of whether the adapter's plug is actually replaced or not.
- If the adapter's plug is not replaced, do not choose "Yes".  
Ink leakage may occur by continuing to use such adapter's plug.
- If you replace the adapter's plug without receiving the replacement message ([\*] Change Plug), go to "[5.7.2.2 Plug Life initialization menu](#)" to initialize the counter which you replaced.  
If not, it continues to count so that the next replacement message will appear shorter than usual.

## 6.5 Cleaning the printer

Follow the instructions on this document or supplied “Daily Maintenance Sheet for VJ-1626UH” and “VJ-1626UH Daily Maintenance Sheet for UV-LED Lamp” to perform maintenance at the end of the daily printer operation.

To keep your printer in good condition, make sure to perform this maintenance.

### WARNING

- **Do not insert or drop metal or flammable objects into the printer through openings such as a vent.**  
It could lead to an electric shock or fire.
- **If foreign substances or liquids such as water entered the printer, do not use the printer as it is.**  
It could lead to an electric shock or fire.  
Immediately turn OFF the power switch, disconnect the power plug from the electric socket, and contact your local MUTOH dealer.

### CAUTION

- **Do not use volatile solvents such as thinner, benzene, or alcohol.**  
These solvents may cause damage to the printer.
- **Be careful that no moisture enters the printer.**  
There is a possibility that the electric circuit inside the printer is short circuited.
- **Do not open covers attached using screws under any circumstances.**  
This may cause an electric shock or a malfunction.

## 6.5.1 Daily Maintenance

This section explains how to perform maintenance at the end of the daily printer operation.

### Flow of Daily Maintenance

This printer requires daily maintenance.

Follow the steps below to perform daily maintenance after you finish your printing for the day.

- “Perform Daily Maint.” is prompted on the operation panel after certain period of time from the previous daily maintenance.  
Make sure to perform daily maintenance when prompted.

#### NOTE

- If you perform printing all day without entering to sleep mode, make sure to perform daily maintenance once a day.  
Failure to perform daily maintenance may affect print quality or result in damage to the printer.
- To perform daily maintenance without entering to sleep mode, go to “Mnt.1: Daily Maint.” on the operation panel.

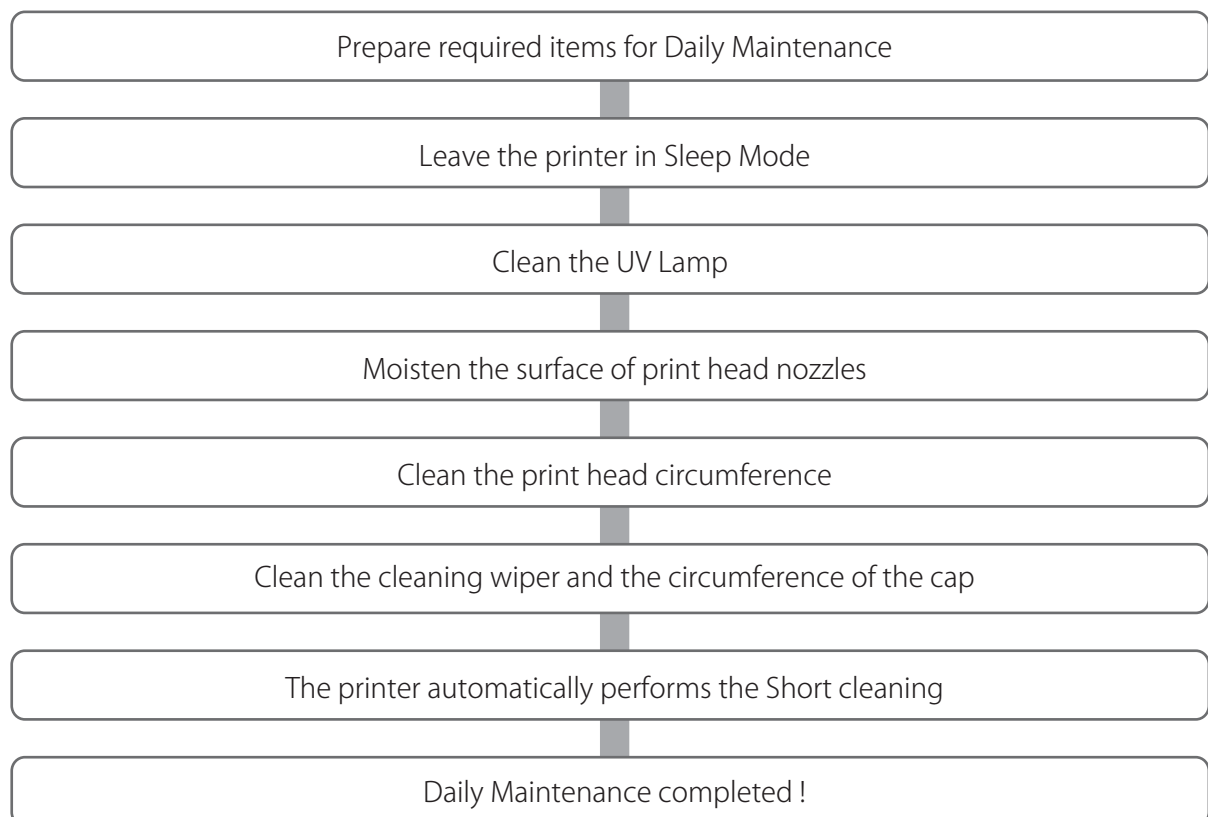

## Preparing for Daily Maintenance

### Required Items

1. Prepare the following items to perform daily maintenance.



Plastic gloves



Rubber gloves



Protective goggles

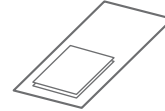

Paper towel  
or Polyester knit wiper



Dropper



Dedicated maintenance  
cleaner



Plastic cup

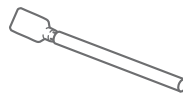

Cleaning stick

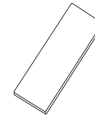

Scraper

### NOTE

- Use a paper towel supplied with the printer or optional polyester knit wiper. DO NOT use a tissue. Lints or flakes on tissue may cause damage to the print head.
- DO NOT use non-dedicated maintenance cleaner.
- If you want to purchase the optional maintenance cleaner, contact your local Mutoh dealer or nearest Mutoh sales office.

2. Wear the rubber gloves (white) over the plastic gloves (pink).
3. Wear protective goggles.

### CAUTION

- **Skin or eye contact with UV curable ink may cause skin inflammation or allergic reaction.**
- **For this operation, be sure to wear the supplied gloves (or solvent resistant gloves) and goggles to prevent ink from contacting with your eyes or skin.**



4. Put the printer into Sleep Mode.
  - ☞ 3.3.1 Set sleep mode on the printer
5. “Daily Maint.: Start” is displayed on Operation panel.
  - Press the [Enter] key.

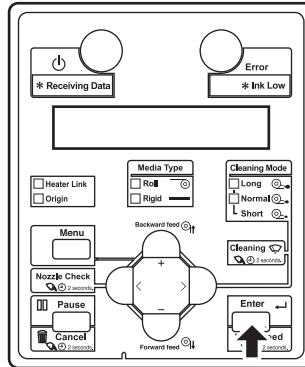

- The carriage and cleaning wiper move to the maintenance position.
  - “Daily Maint.: End” is displayed on Operation panel.
6. You can start maintenance.

#### NOTE

Make sure to complete this maintenance within 10 minutes while the printer is in Daily maintenance state.

## Performing Daily Maintenance

### CAUTION

- **Always follow this steps to perform daily maintenance.**  
**When moistening the surface of nozzles, do not use the cleaning stick already used to clean the print head circumference, cleaning wiper or cap circumference. Doing so may result in damage to the print head.**
- **Always use a new cleaning stick and dampen it with dedicated maintenance cleaner.**  
**DO NOT use non-dedicated maintenance cleaner. It may cause nozzle clogging.**
- **Do not touch the tip of a cleaning stick with fingers.**  
**If sebum is adhered, it can cause damage to the print head.**
- **Do not reuse a cleaning stick.**  
**Dusts can adhere causing damage to the print head.**

### 1. Cleaning of UV-LED Lamp

1. Open Maintenance cover on the left of the printer and remove it.

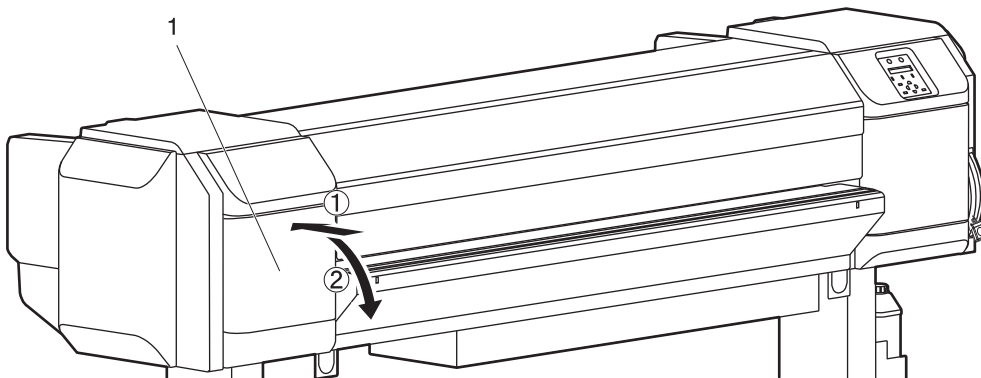

2. Check for any ink or dust on the UV lamp.

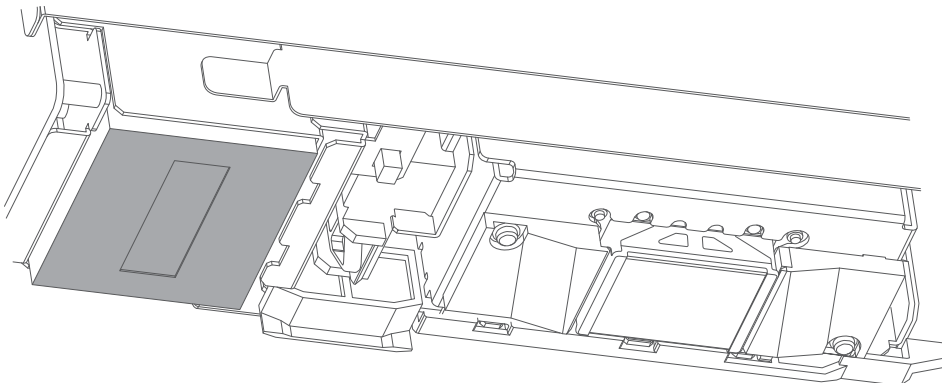

- If no ink or dust is found on the UV lamp, skip this step and move on to “ 2. Moistening the surface of print head nozzles”.
3. Using a paper towel, remove ink and dust from the UV lamp.  
If ink deposits cannot be removed with the paper towel, use the scraper supplied with the printer.
- Press the scraper on the ink deposits with a slight angle and scrape off the ink deposits.
  - Use the paper towel to clean the ink scraped from the lamp.

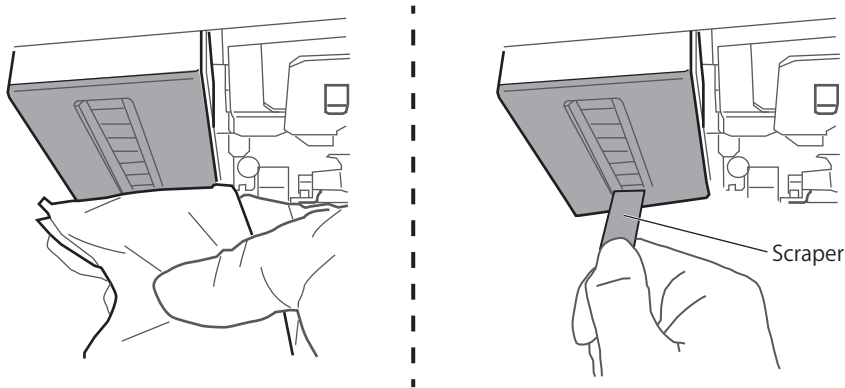
**CAUTION**

- **Make sure to use the scraper supplied with the printer.**
- **Never use the corner of the scraper. It can damage the UV lamp.**
- **When using the scraper, do not apply too much pressure to the lamp. It can damage the UV lamp.**

4. Next moisten the surface of print head nozzles.

## 2. Moistening the surface of print head nozzles

### 1. Put a cleaning stick in the plastic cup.

- Use the dropper to dampen the swab of cleaning stick with dedicated maintenance cleaner. (Amount used: 0.5 ml)

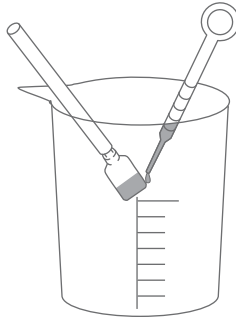

### 2. Look the bottom of the carriage.

Using the cleaning stick dampened with the maintenance cleaner, moisten the surface of the print head nozzles.

- Lightly touch with the cleaning stick to moisten the nozzle surface.
- Repeat it a couple of times to moisten the entire nozzle surface.

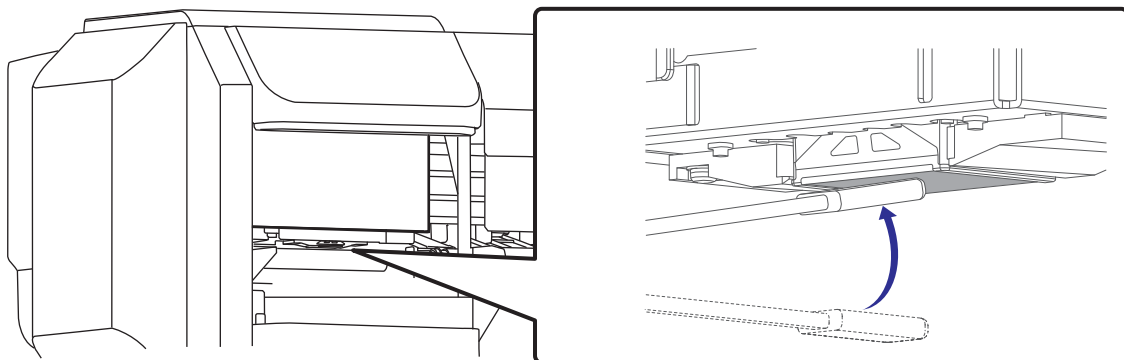

### CAUTION

- **DO NOT rub into the nozzle surface. It can cause damage to the print head.**
- **If the entire nozzle surface has been moistened, you can stop it.**

### 3. Next clean the print head circumference.

## 3. Cleaning of print head circumference

1. Look the bottom of the carriage.  
Check if dusts and ink deposit are adhered.
  - Print head circumference (silver metal part)
  - Print head guide part (black plastic part)

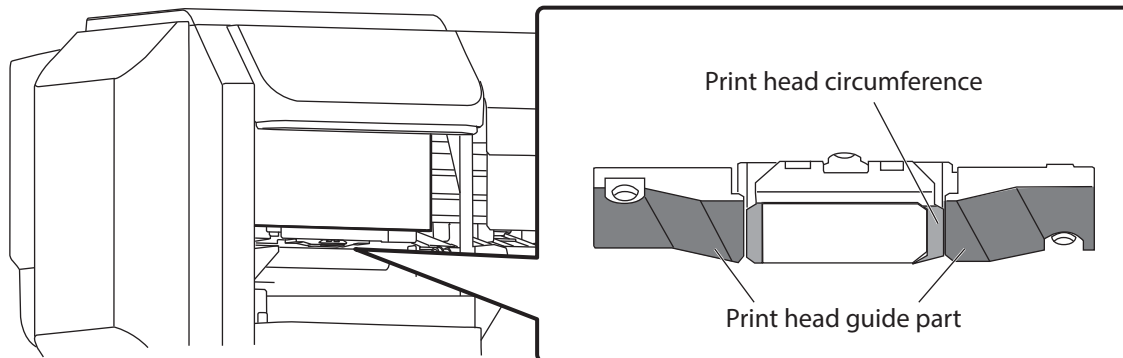

2. Use the cleaning stick to remove the ink and dust on the bottom of the carriage.

 Cleaning required

 **DO NOT touch the surface of a print head (the yellow portions in the illustration below)**

Print head circumference (silver metal part)

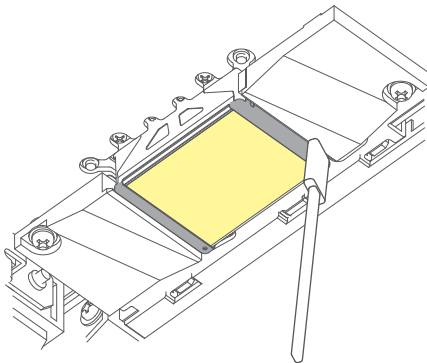

Print head guide part (black plastic part)

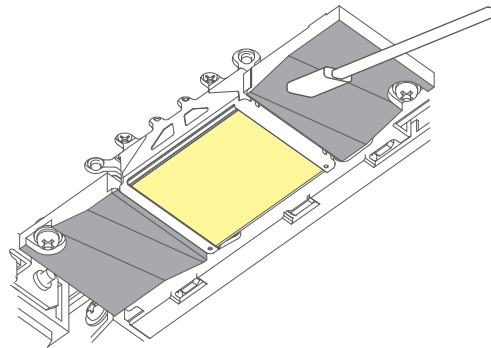

- **If maintenance cleaner is splashed onto the printer, use a paper towel to wipe it off.**

3. Attach the maintenance cover on the left of the printer and close it.
4. Next clean the cleaning wiper and the cap circumference.

#### 4. Cleaning of cleaning wiper and the circumference of the cap

1. Open Maintenance cover on the right of the printer and remove it.

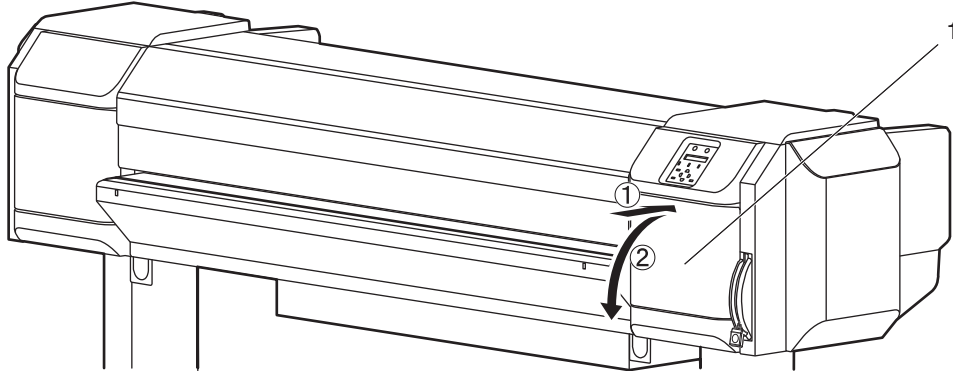

2. Use the cleaning stick to clean the left side surface of the cleaning wiper (a black rubber part).

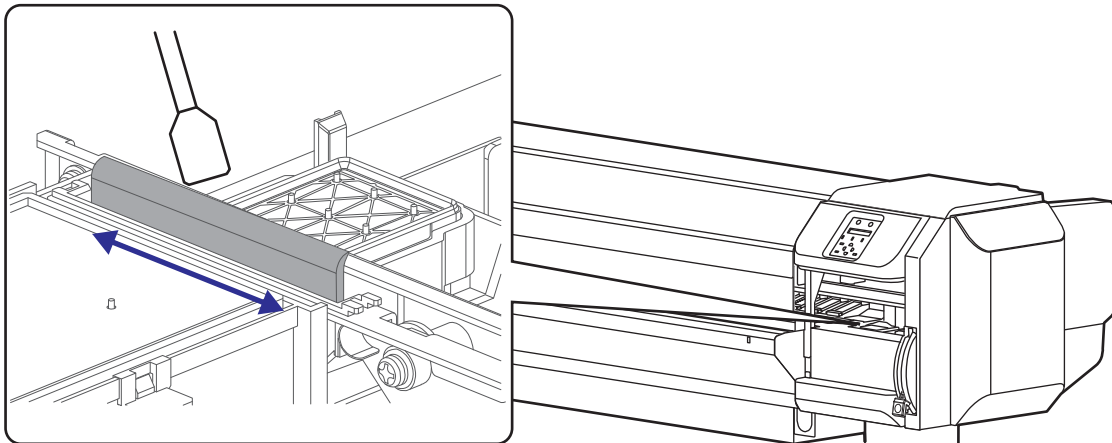

3. Clean the right side surface of the cleaning wiper.

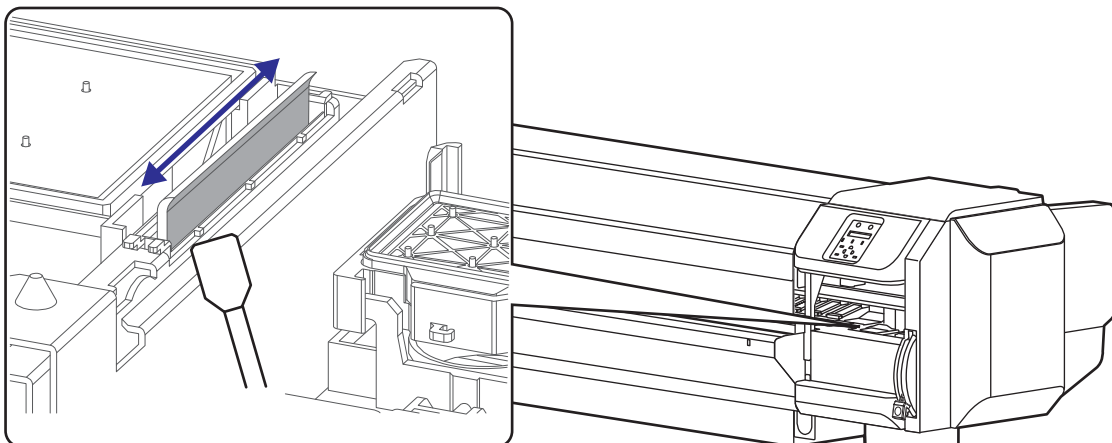

4. Use the cleaning stick to remove the ink and dust on the circumference of the cap.

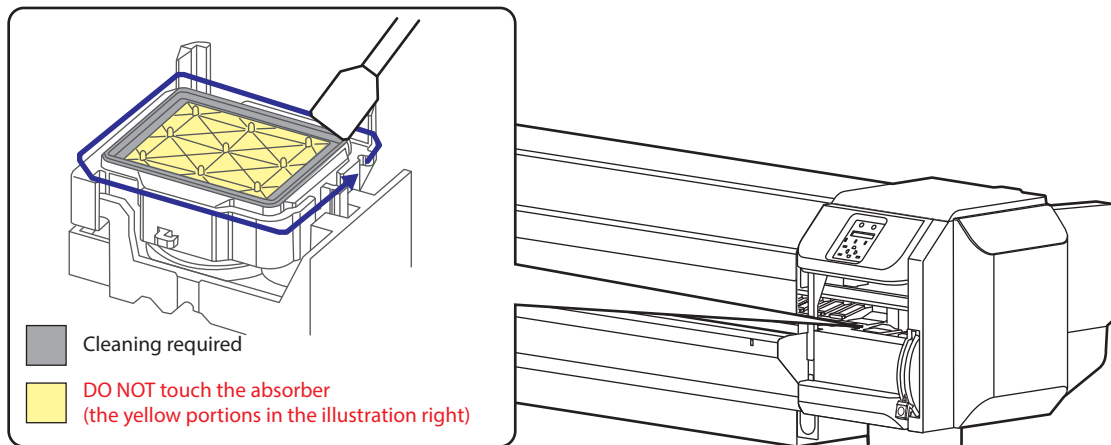

5. Attach the maintenance cover on the right of the printer and close it.
6. Next finish the daily maintenance.

## 5. Finishing daily maintenance

1. “Daily Maint.: End” is displayed on Operation panel.

- Press the [Enter] key.

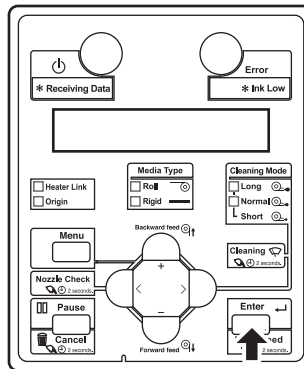

- The printer moves the carriage and the cleaning wiper back to each original position.
  - The printer automatically performs the “Short” cleaning.
  - When the “Short” cleaning is complete, the printer automatically enters to sleep mode.
2. Dispose of the used cleaning stick.
  3. Use a paper towel to wipe the maintenance cleaner off the dropper.
  4. Dispose of the maintenance cleaner in the plastic cup and dry the cup well using the paper towel.



### CAUTION

- **Do not reuse a cleaning stick.**  
Dusts can adhere causing damage to the print head.
- **Check that the lid of the maintenance cleaner is shut properly and store it.**

5. Now the daily maintenance is complete.



### 6.5.2 Head cleaning

If printed data is blurred or lacks part of it, clean the print head surface and nozzle (Head cleaning).

Follow the procedure below to perform Head cleaning.

**NOTE**

Remove media when cleaning.  
 Cleaning with media loaded may lead to contact between the print head and media.

1. Confirm that the operation panel is Normal.
2. Make sure that Front media loading lever is lowered (Rear media loading lever is raised).
3. Press the [>] key to select the cleaning mode.

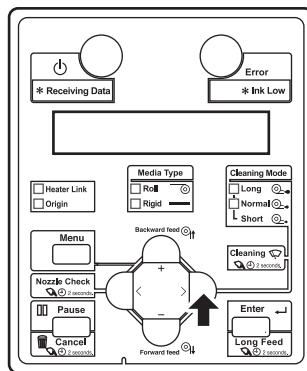
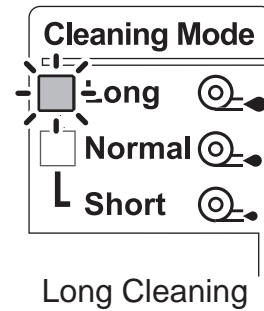
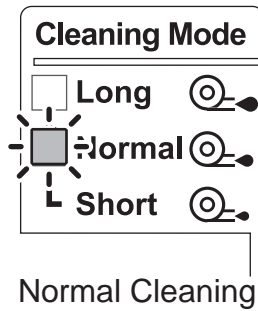
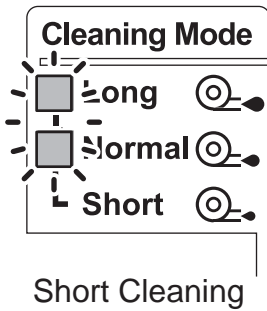

- Press the [Cleaning] key for at least 2 seconds.

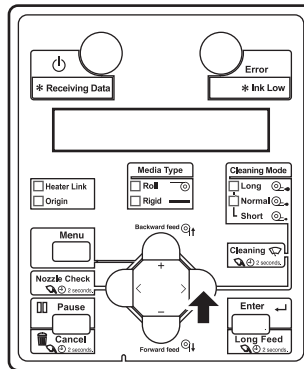

- Start Head cleaning.
- “Cleaning \*\*%” is displayed.
- After Head cleaning is complete, the operation panel shifts to Normal.

#### NOTE

- If blurs or lacking parts in printed media do not disappear with one time of Head cleaning, perform “Long” cleaning.
- When nozzle clogging remains even after repeating “Long cleaning” several times, conduct “6.5.3 Clean daily maintenance parts”.
- If the nozzle clog still is not rectified, carry out “LittleCharge” via the Cleaning submenu in the Panel Setting Menus.  
[☞ 5.5 Cleaning menu](#)
- If blurs or lacking parts in printed media do not disappear with several times of Head cleaning, refer to [7 Troubleshooting](#), and take appropriate measures.

### 6.5.3 Clean daily maintenance parts

In following cases, clean the daily maintenance parts.

- When print blurring and dot missing remain after head cleaning is done.
- If you perform printing all day without entering to sleep mode and you need to perform daily maintenance.

#### Preparation:

See “ [Preparing for Daily Maintenance](#)” to prepare items required for the maintenance.

#### NOTE

If you want to continuously use the printer after this maintenance, follow the steps below.  
If you will not use the printer after this maintenance, enter to sleep mode and then perform maintenance.

[6.5.1 Daily Maintenance](#)

#### 1. Putting the printer into the Daily maintenance mode

1. Check that printing is completed.
2. Press the [Menu] key.

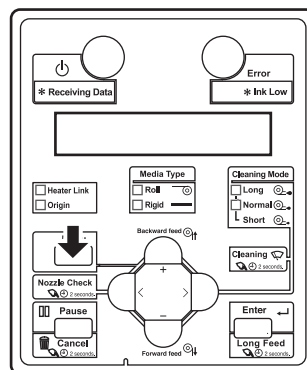

3. Use the [+] or [-] key on Operation panel to select “Menu 7: Maintenance >”.

- Press the [>] key.

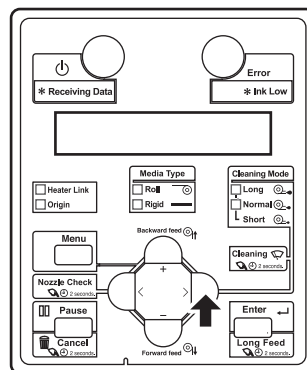

4. “Mnt. 1: Daily Maint.” is displayed on the operation panel.

- Press the [Enter] key on the operation panel.

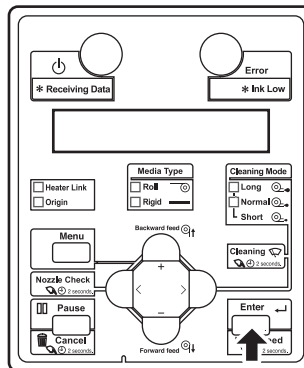

5. “Daily Maint.: Start” is displayed on the operation panel.

- Press the [Enter] key on the operation panel.

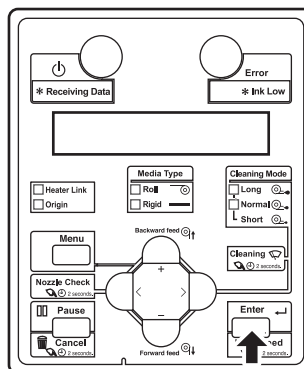





- The carriage and cleaning wiper move to the maintenance position.
- “Daily Maint.: End” is displayed on the operation panel.
- You can start maintenance.

## 2. Cleaning daily maintenance parts

The maintenance procedure and parts to be cleaned are the same as “6.5.1 Daily Maintenance”.

Follow the steps described in “ Performing Daily Maintenance”to clean each part.

-  1. Cleaning of UV-LED Lamp
-  2. Moistening the surface of print head nozzles
-  3. Cleaning of print head circumference
-  4. Cleaning of cleaning wiper and the circumference of the cap

### NOTE

Make sure to complete this maintenance within 10 minutes while the printer is in Daily maintenance state.

## 3. Finishing maintenance

1. “Daily Maint.: End” is displayed on the operation panel.
  - Press the [Enter] key on the operation panel.

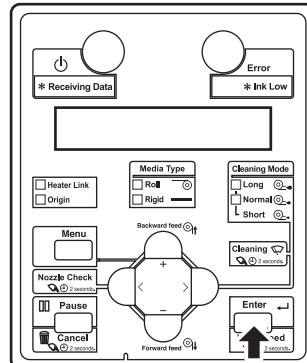

- The printer automatically performs the “Short” cleaning.
  - When the “Short” cleaning is complete, the printer automatically enters to sleep mode.
2. Dispose of the used cleaning stick.
  3. Use a paper towel to wipe the maintenance cleaner off the dropper.
  4. Dispose of the maintenance cleaner in the plastic cup and dry the cup well using the paper towel.

**CAUTION**

- **Do not reuse a cleaning stick.**  
Dusts can adhere causing damage to the print head.
- **Check that the lid of the maintenance cleaner is shut properly and store it.**

5. Now the daily maintenance is complete.

### 6.5.4 Cleaning the outer case

This sub-section describes how to clean the outer case.

Wipe out dust and dirt attached to the outer case by using a soft cloth.

Periodic (every month) cleaning is necessary.

### 6.5.5 Cleaning the inside of the printer

This sub-section describes how to clean the inside of the printer.

Periodic (every month) cleaning is necessary.

Follow the procedure below.

1. Open the front cover.

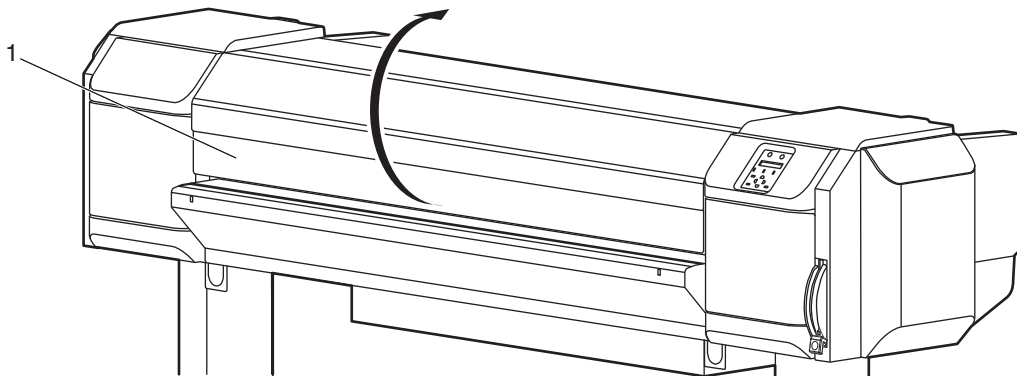

No.	Name
1	Front cover

- Remove paper powder and dust attached to the pressurizing rollers using a soft brush.

**NOTE**

Do not blow paper powder inside the printer using tools such as an air duster. It may cause an abnormal noise from the inside of the printer.

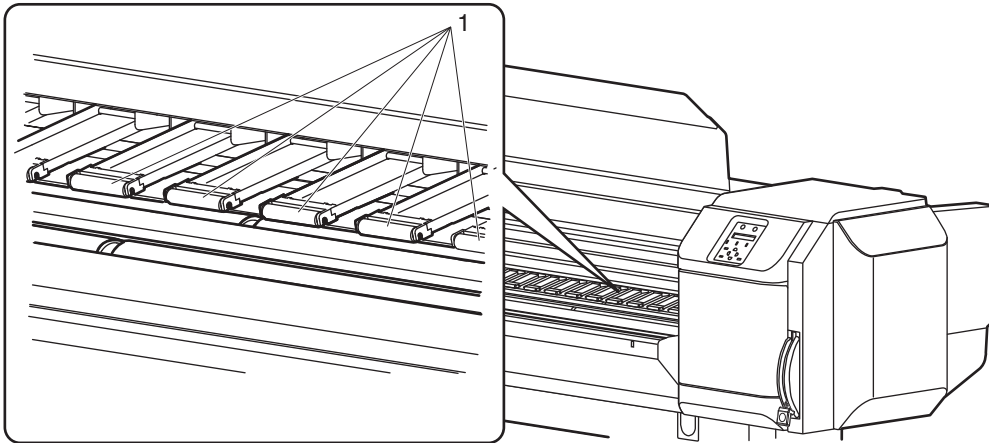

No.	Name
1	Pressurizing rollers

- Apply a damp and tightly squeezed soft cloth to wipe out paper powder and ink attached to the platen and media guide.

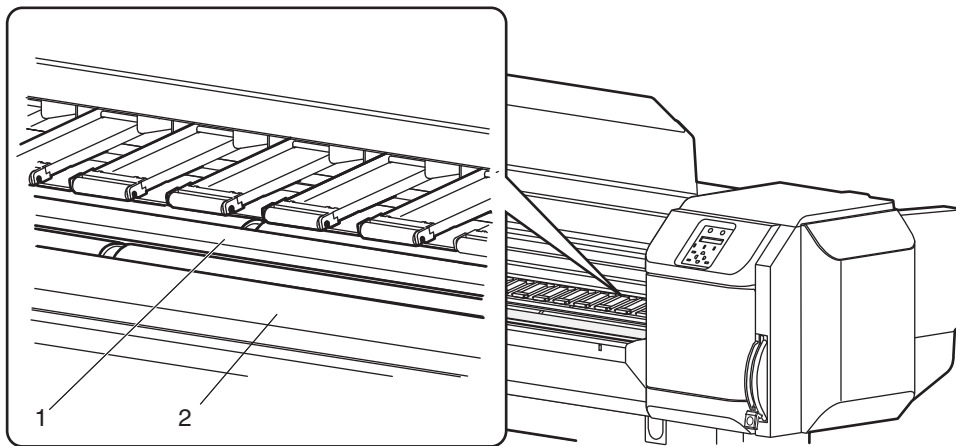

No.	Name
1	Platen
2	Media guide

- 4. Apply a damp and tightly squeezed soft cloth to wipe off the dirt of the unpainted (silver color) area in the center of the grid roller.

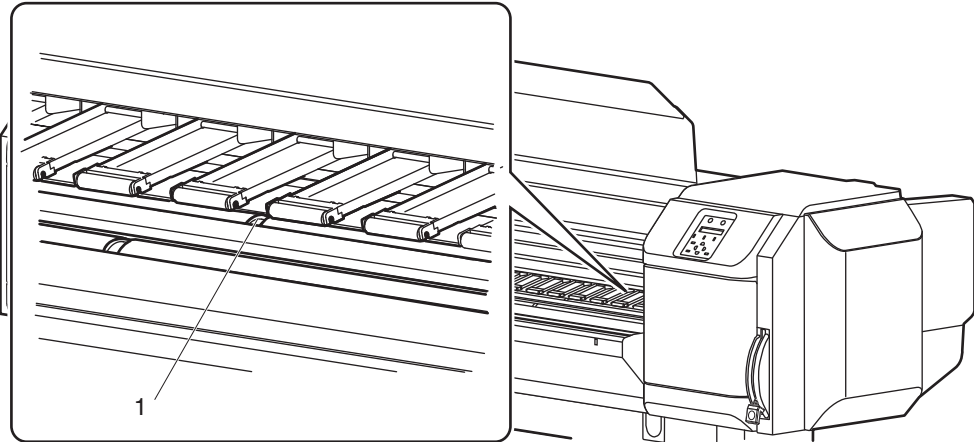

No.	Name
1	Grid roller



## 6.6 Disposal the waste fluids

The timing and method for the disposal of waste fluid are described below.

### (1) Disposal timing

Dispose the waste fluids in the following cases:

- a. When the waste fluid tank is more than half full.
- b. When “Full WasteInkTank” is displayed.

### (2) Disposal method

Follow the procedure below to dispose of waste fluid.

#### **WARNING**

- **The waste fluid from the printer is industrial waste. Proper waste fluid disposal according to industrial waste disposal laws and ordinances of your local government is required. Consign disposal of waste fluids to a specialized processor.**
- **Waste fluid from this product is harmful to aquatic organisms. Avoid the waste fluid from out flowing to sewage or natural water systems.**

#### **CAUTION**

- **Ink and waste fluid are harmful to skin. During this operation, wear the supplied gloves and make sure that ink does not adhere to your skin. Wear safety goggle and protective clothing if necessary. Skin or eye contact with UV curable ink may cause skin inflammation or allergic reaction.**
  - **If the ink adheres to your skin, wash with soap and a large amount of water immediately; consult a doctor if an abnormal symptom occurs.**
  - **If the ink gets in your eyes, wash with a large amount of water and immediately see a doctor.**

1. Ready an empty container such as a supply waste fluid bottle, to contain the waste fluid.
2. Lay a protective material on the floor under the waste fluid tank.

3. Press on the absorbent material tray of the waste fluid valve to store it.

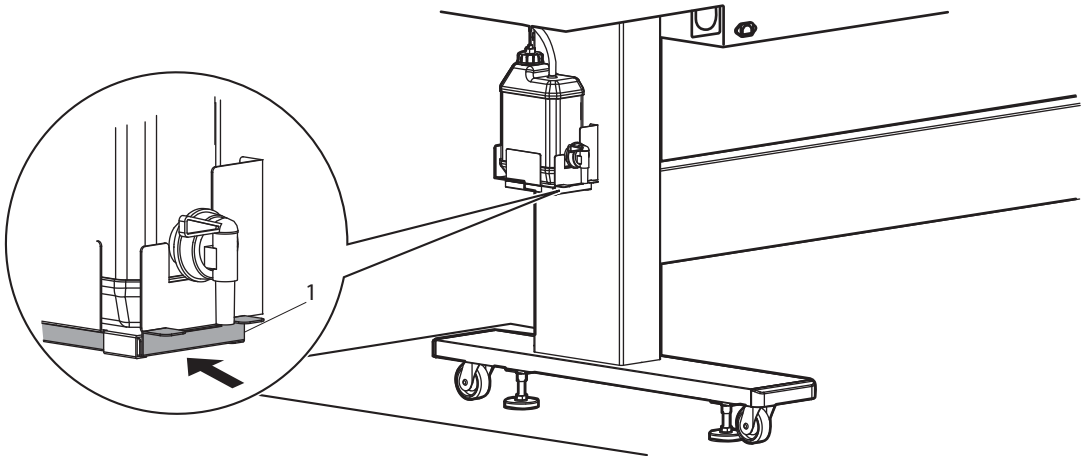

No.	Name
1	Waste fluid tank holder
2	Absorbent material tray

4. Open the waste fluid valve, and transfer the waste fluid to the container.

**NOTE**

When pouring the waste fluid to the empty container, the waste fluid may splash, therefore put the container close to the waste fluid valve.

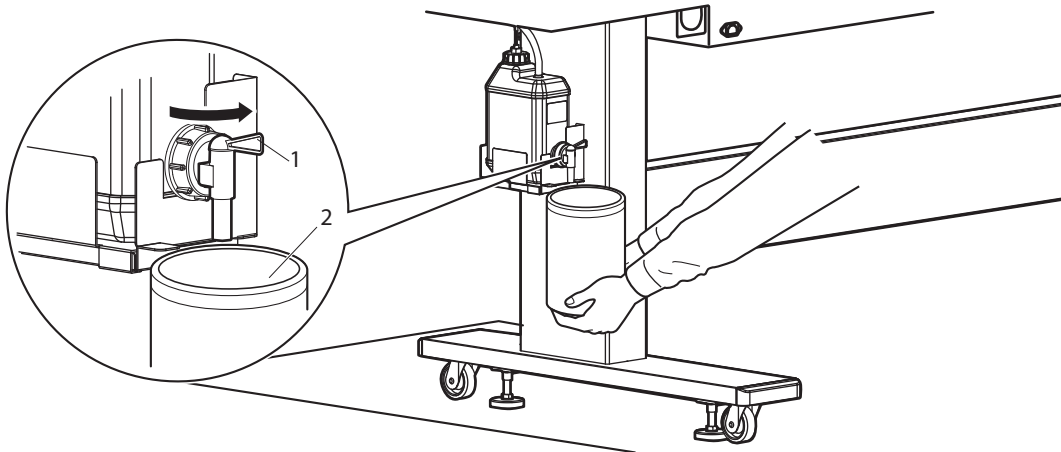

No.	Name
1	Waste fluid valve
2	Empty container

5. After pouring the waste fluid to the empty container, close the waste fluid valve securely.

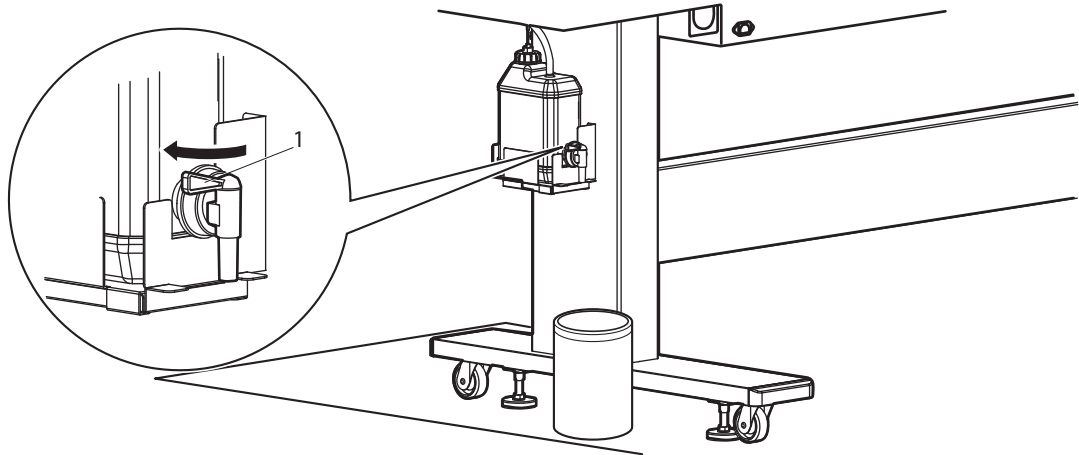

No.	Name
1	Waste fluid valve

6. Wipe the opening of the waste fluid valve with a cloth, etc.
7. Pull out the absorbent material tray.

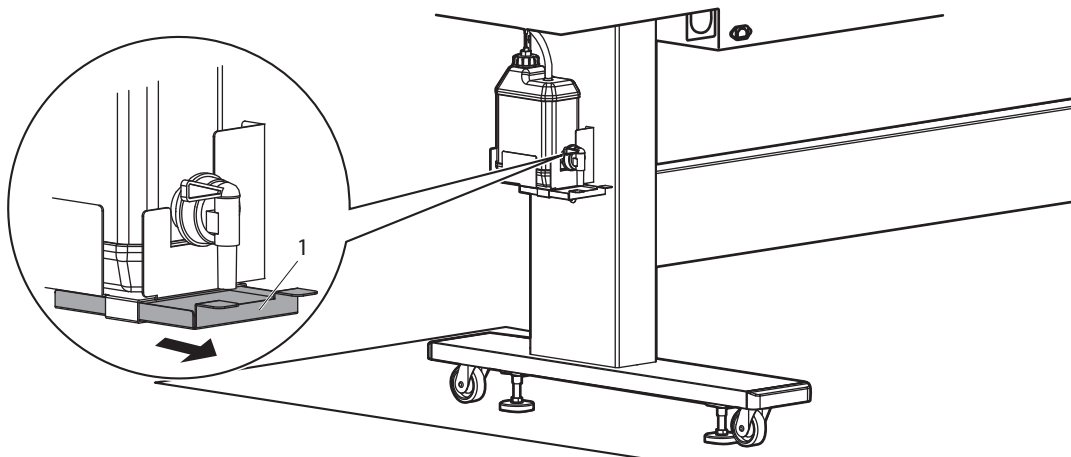

No.	Name
1	Absorbent material tray

8. Dispose of the waste fluid as an industrial waste product.
  - Disposal of waste fluids is completed.

## 6.7 Transporting the printer

This section describes how transport the printer.

### CAUTION

- **Move the printer maintaining a horizontal position.**
- **Do not slant the printer, prop it against a wall or turn it upside down.**  
**There is a possibility that ink inside the printer may leak.**  
**Moreover, normal operation after shifting (to these positions) cannot be guaranteed.**

### 6.7.1 Transporting the printer

#### (1) Preparation before transporting

Follow the procedure below to transport the printer.

1. Performs Head cleaning using the cleaning liquid.  
[☞ 5.7.3 Ink Discharge menu](#)
2. Confirm that the printer is OFF.  
[☞ 3.2.2 Turning the power OFF](#)
3. Dispose the waste fluids.  
[☞ 6.6 Disposal the waste fluids](#)
4. When Media-feed table (optional) is installed, remove it from the printer.  
[☞ 3.5.3 Removing Media-feed table \(optional\)](#)
5. Remove all the cables, such as the power cable.
6. Attach protection materials, and place the product inside the package box.
  - When transporting the printer, it is necessary to pack in the same condition as purchased using protective and packing materials to protect the printer from vibration and shocks.

### NOTE

When transporting the printer, consult the MUTOH product dealer at your point of purchase.

## (2) Reinstalling

After transporting the printer, follow the procedure below to set it ready for use.

1. Select a suitable place for installation.
  - ☞ Installation manual
2. Move and install the printer to the location.
3. Attach cables, such as the power cable.
  - ☞ 3.1 Power cable connection
  - ☞ 3.7 Adjust print
4. Perform the initial ink charge.
  - ☞ 6.7.2 How to carry out initial ink charging after ink discharge
5. Perform Nozzle check, and then confirm that there is no clogging in the print head.
  - ☞ 3.6.1 Nozzle check
6. Perform Alignment.
  - ☞ 3.7 Adjust print

### 6.7.2 How to carry out initial ink charging after ink discharge

After transporting the printer, perform initial charge before printing. Because cleaning using the cleaning liquid is not required, the procedure is partially different from ☞ 3.4 Initial ink charging.

Follow the procedure below to perform initial ink charging at the time of recovery.

1. Turn the printer ON.
  - ☞ 3.2.1 Turning the power ON
    - The printer starts the initial operation.
    - After the initial operation is complete, “Start Ink Charge -> E” is displayed.
2. Press the [Enter] key.

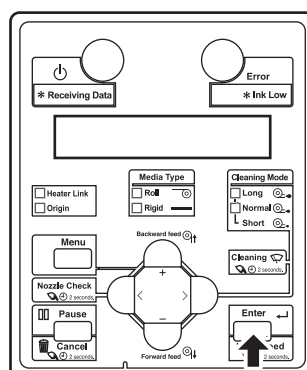

- “Empty WasteInk -> E” is displayed.
- Check Waste fluid tank and dispose any waste fluid.

3. Press the [Enter] key.

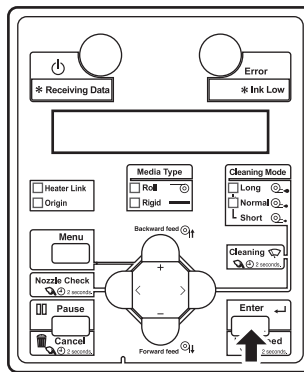

- “Insert Ink Cartridges” is displayed.

4. Prepare ink cartridges.

- The type and quantity of the ink cartridge to be used differ depending on the set number of colors to be used.

(1) When using 6-color set

- Cyan (C): 1
- Magenta (M): 1
- Yellow (Y): 1
- Black (K): 1
- Varnish (VA): 1
- White (WH): 1

(2) When using 4-color set

- Cyan (C): 2
- Magenta (M): 2
- Yellow (Y): 1
- Black (K): 1

#### NOTE

Make sure to prepare new ink cartridges.  
If not, the printer may not properly perform initial ink charging.

## 5. Shake ink cartridge.

- Turn the ink plug upward and wait for 3 seconds.
- Next, turn the ink plug downward and wait for 3 seconds.
- Repeat that 10 times.

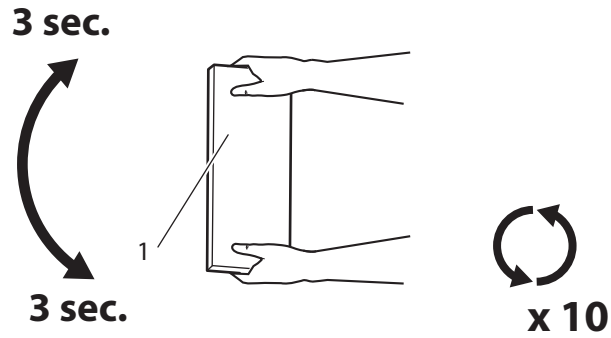

No.	Name
1	Ink cartridge

## 6. Install ink cartridges into Ink cartridge slots.

**NOTE**

Note that the ink colors and corresponding ink cartridge slots differ depending on the number of ink colors you are using.

## (1) When using 4-color set

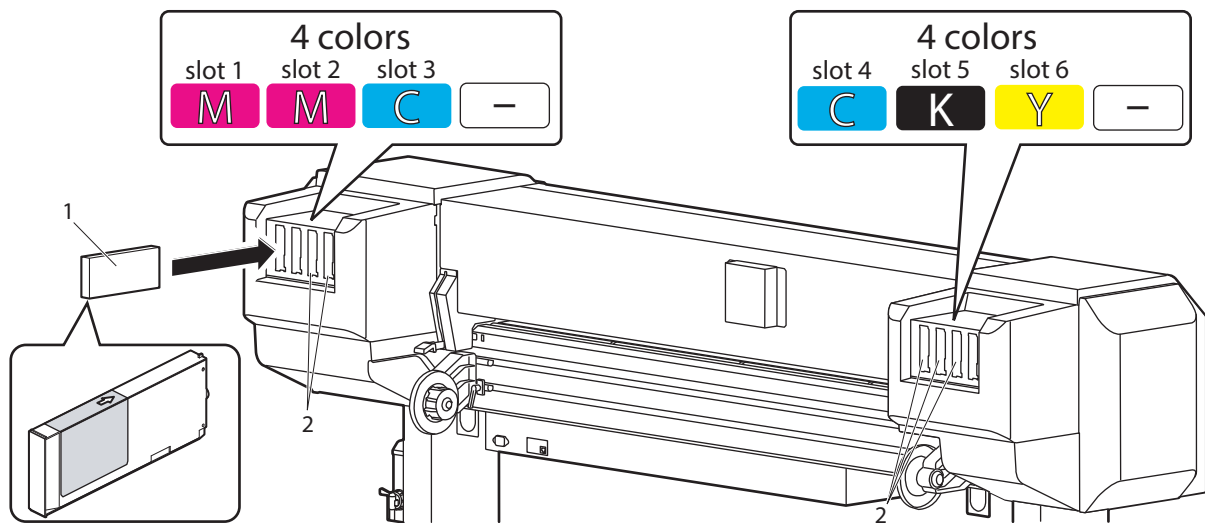

No.	Name
1	Ink cartridge
2	Ink cartridge slots

## (2) When using 6-color set

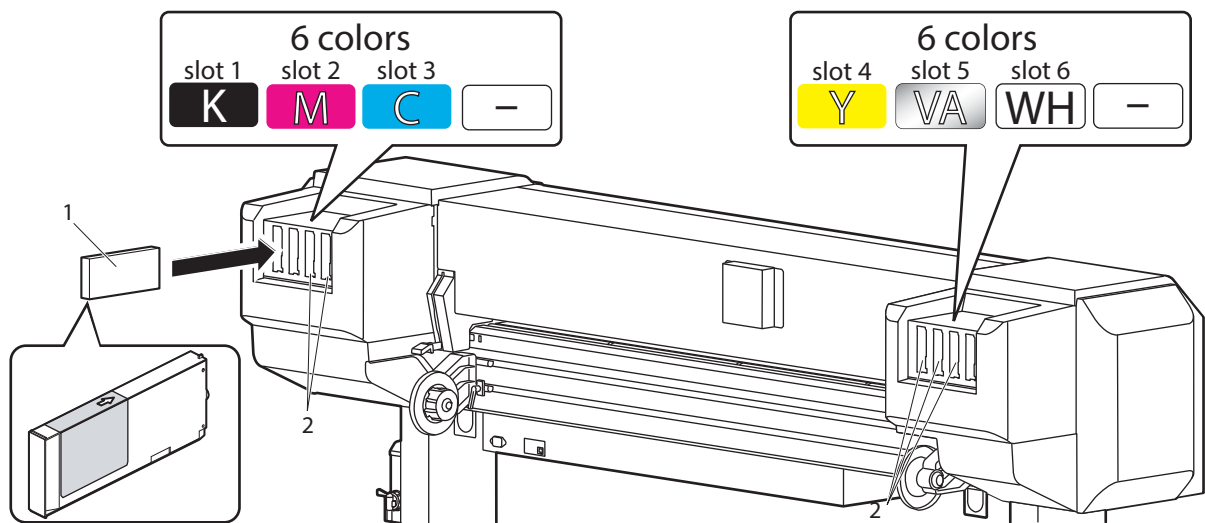

No.	Name
1	Ink cartridge
2	Ink cartridge slots

- You can check the ink color labels for ink colors and its cartridge slots.
- Keep the arrow of ink cartridge facing up and insert it into the printer.
- Insert ink cartridges all the way in Ink cartridge slot.



- When a ink cartridges are installed, “Ink Refill \*\*%” is displayed and ink charging starts.
- Initial ink charging takes about 9 minutes.
- Ink charging operation and pause operation are repeated during the initial ink charging.
- When “100%” is displayed, the initial ink charging is complete.
- After the initial ink charging is complete, “Media End” is displayed.

**CAUTION**

- **Comply strictly with the following during ink charging.**  
**If charging is interrupted, ink will be lost when charging is resumed.**
  - **Do not turn OFF the printer.**
  - **Do not unplug the power cord set of the printer.**
  - **Do not open Front cover.**
  - **Do not open Maintenance cover.**
  - **Do not raise Front media loading lever (i.e., Do not lower Rear media loading lever).**
  - **Do not use ink cartridges that have little ink remaining.**

**NOTE**

If the printer perform the nozzle check printing immediately after initial charging is complete, the following results may occur.

- Printed lines become blurred.
- The data is partially not printed.

In such cases, follow “[5.5 Cleaning menu](#)” and perform “Little Charge”. Then, check the printing result.

If there is no improvement in the print result even after performing “Little Charge”, leave the printer unused for an hour or more. Then, perform “Little Charge” again and check the print result.

If there is still no improvement, contact your local MUTOH dealer.



## 7 Troubleshooting

This chapter describes possible troubles during the use of this product and countermeasures.

If the error in any items of this section occurs, contact your local MUTOH dealer.

**NOTE**

---

If you want to receive product warranty, prepare the warranty certificate.

If the warranty certificate is not presented, the repair will not be covered by the warranty even if within the warranty period.

If you have signed a maintenance service contract, prepare that or a similar document.



---

## 7.1 Malfunctions and failures



This section describes undisplayed malfunctions and failures of the printer, possible causes and countermeasures.

### 7.1.1 Problems in installation and introduction

#### (1) Cannot perform the initial ink charge





No.	Possible cause	Remedy	Reference
1	Is Front cover open, or Front media loading lever raised (Rear media loading lever lowered)?	Close Front cover, and lower Front media loading lever (raise Rear media loading lever).	 <a href="#">3.5 Setting media</a>
2	Is the maintenance cover open?	Close the maintenance cover.	—
3	Are ink cartridges inserted all the way into the printer?	Make sure ink cartridges are all inserted properly.	 <a href="#">6.4.1 Replacing ink cartridges</a>
4	Is the waste fluid sensor cable inserted?	Fully insert the waste fluid sensor cable to the waste fluid sensor connector.	 Installation manual

#### (2) Ink does not come out after ink charging





No.	Possible cause	Remedy	Reference
1	Is the ink cartridge cold and frozen?	Leave the ink cartridge at room temperature for at least 3 hours, and perform cleaning several times.	 <a href="#">6.5.2 Head cleaning</a>
2	Is the power turned OFF during ink charging?	Turn the power ON again and continue ink charging.	 <a href="#">3.4 Initial ink charging</a>
3	Occasionally, normal printing cannot be performed after ink charging.	Perform little charge.	 <a href="#">5.5 Cleaning menu</a>

## 7.1.2 Cannot print at all

### (1) Does not work at all after power activation

No.	Possible cause	Remedy	Reference
1	Is the power cable connected to the plug?	Connect the power cable.	 <a href="#">3.1 Power cable connection</a>
2	Does the AC power supply provide the specified voltage?	Connect the cable to another outlet.	 <a href="#">3.1 Power cable connection</a>
3	Is the front cover open or media loading lever raised?	Close the front cover. Lower the media loading lever.	 <a href="#">3.5 Setting media</a>
4	Is the maintenance cover open?	Close the maintenance cover.	 <a href="#">2.2 Names of parts and functions</a>



### (2) Does not work after loading the media

No.	Possible cause	Remedy	Reference
1	Is Front cover open, or Front media loading lever raised (Rear media loading lever lowered)?	Close Front cover, and lower Front media loading lever (raise Rear media loading lever).	 <a href="#">3.5 Setting media</a>
2	Is the maintenance cover open?	Close the maintenance cover.	 <a href="#">2.2 Names of parts and functions</a>
3	Is the media loaded at an angle?	Load the media straight.	 <a href="#">3.5 Setting media</a>
4	Are ink cartridges inserted into the printer?	Insert ink cartridges.	 <a href="#">6.4.1 Replacing ink cartridges</a>
5	Is the printer being used in an environment other than the one specified, such as in direct sunlight?	Only use the printer in an environment that is specified for use.	 <a href="#">Installation manual</a>

### (3) When data is sent from the computer, an error occurs at the printer and nothing is printed







No.	Possible cause	Remedy	Reference
1	Is the type of printer selected correctly at the computer?	Check that the printer type settings on the computer side and printer side are the same.	 <a href="#">3.8 Connecting the printer to PC</a>
2	Are the interface requirements and command mode the same on the computer side and printer side?		

**(4) Cannot use the computer online using LAN**

No.	Possible cause	Remedy	Reference
1	Is the network interface cable connected correctly?	Confirm the types of the cross and straight cables, and connect the network interface cable correctly.	 <a href="#">3.8.3 Connecting a network interface cable</a>
2	Are the network settings configured correctly?	Configure the network settings correctly.	 <a href="#">3.8.4 Setting the IP address to 3.8.6 Gateway setting</a>
3	Match the printer's network settings with the computer side environment.	Match this product's network settings with the computer side environment.	 <a href="#">3.8.1 System requirements</a>
4	Does the Power lamp turn on after sending printing data from the computer?	If the Power lamp does not turn on, contact the computer manufacturer.	—





**7.1.3 Media-related troubleshooting****(1) The media slips or is torn during initialization****NOTE**

If the media is jammed or torn, remove it according to “[7.3 The media is jammed](#)”.





No.	Possible cause	Remedy	Reference
1	Is the loading position of the media correct?	Set the media correctly.	 <a href="#">3.5.5 Setting roll media</a>
2	Is the roll media set correctly?	Set the roll media correctly.	 <a href="#">3.5.4 Loading roll media</a>
3	Are there any foreign materials such as paper attached to the pressurizing roller?	Clean the pressurizing roller.	 <a href="#">6.5.5 Cleaning the inside of the printer</a>
4	Is the printer being used in an environment other than the one specified, such as in direct sunlight?	Only use the printer in an environment that is specified for use.	 Installation manual
5	Are you using folded, torn or rolled media?	Replace the media.	 <a href="#">4.2.2 Caution on handling media</a>
6	Does the media bend?	Set the Vacuum Fan menu.	 <a href="#">5.2.2.4 Vacuum Fan menu</a>
7	Is the media thickness value correct?	Re-set so that media thickness detection will be conducted, and then re-set the media.	 <a href="#">5.2.2.7 Media Initial menu</a>

**(2) The media is crumpled during initialization****NOTE**





If the media is jammed or torn, remove it according to “7.3 The media is jammed”.

No.	Possible cause	Remedy	Reference
1	Is the loading position of the media correct?	Set the media correctly.	 <a href="#">3.5.5 Setting roll media</a>
2	Is the media loaded at an angle?	Set the media straight.	 <a href="#">3.5.5 Setting roll media</a>
3	Are there any foreign materials such as paper attached to the pressurizing roller?	Clean the pressurizing roller.	 <a href="#">6.5.5 Cleaning the inside of the printer</a>
4	Is the printer used in an environment other than the one specified, such as near an air conditioner?	Only use the printer in an environment that is specified for use.	 <a href="#">Installation manual</a>
5	Are you using folded, torn or rolled media?	Replace the media.	 <a href="#">4.2.2 Caution s on handling media</a>



**(3) The wrong media size is set during initialization**

No.	Possible cause	Remedy	Reference
1	Is the media loaded at an angle?	Set the media straight.	 <a href="#">3.5.5 Setting roll media</a>
2	When the media is set, does it curl upward?	Straighten the media or set a new media.	 <a href="#">3.5.5 Setting roll media</a>
3	Is the printer being used in an environment other than the one specified, such as in direct sunlight?	Only use the printer in an environment that is specified for use.	 <a href="#">3.5.4 Loading roll media</a>
4	Are you using media that has been printed on already?	Use a new media.	 <a href="#">6.4.2 Replacing roll media</a>
5	Is the media thickness value correct?	Re-set so that media thickness detection will be conducted, and then re-set the media.	 <a href="#">5.2.2.7 Media Initial menu</a>

**(4) Media jams frequently occur**

No.	Possible cause	Remedy	Reference
1	Is the media used in an environment other than the one specified?	Use the media in a dedicated environment.	 <a href="#">4.2.2 Caution on handling media</a>
2	Are you using the old media?	Replace it with new media.	 <a href="#">6.4.2 Replacing roll media</a>
3	Are you using the folded or wrinkled media?		
4	Does the media bend?	Use the recommended media. When using media other than the dedicated one, set the Vacuum Fan menu.	 <a href="#">4.2.1 Loadable media</a>  <a href="#">5.2.2.4 Vacuum Fan menu</a>



**(5) The media veers during printing**

No.	Possible cause	Remedy	Reference
1	Is the loading position of the media correct?	Set the media correctly.	 <a href="#">3.5.5 Setting roll media</a>
2	Is the roll media set correctly?	Set the roll media correctly.	 <a href="#">3.5.4 Loading roll media</a>





## 7.1.4 Printing-related troubleshooting



### (1) Printing is partially stained or incomplete

No.	Possible cause	Remedy	Reference
1	Does the media include moisture?	Replace it with new media.	 <a href="#">6.4.2 Replacing roll media</a>
2	Are you using the folded or wrinkled media?		
3	Does the media bend?	Set the Vacuum Fan menu.	 <a href="#">5.2.2.4 Vacuum Fan menu</a>





### (2) The printing position is incorrect (some parts of the media cannot be printed on)

No.	Possible cause	Remedy	Reference
1	Is the loading position of the media correct?	Set the media correctly.	 <a href="#">3.5.5 Setting roll media</a>
2	Did you set up the origin and print position?	Cancel or reset the settings of the origin and print position.	 <a href="#">5 Panel setup menu</a>



### (3) Printing is blurred

No.	Possible cause	Remedy	Reference
1	Is the media printed on the printing surface?	Confirm the printing surface of the media and set it correctly.	 <a href="#">3.5 Setting media</a>
2	Did you perform Alignment?	Perform Alignment.	 <a href="#">3.7 Adjust print</a>
3	Did you perform Media feed adjustment?	Perform Media feed adjustment.	 <a href="#">4.2.6 Media feed adjustment</a>

### (4) White or black lines appear on printed media

No.	Possible cause	Remedy	Reference
1	Is the roll media set correctly?	Set the roll media correctly.	 <a href="#">3.5.4 Loading roll media</a>
2	Is the nozzle in good condition?	Perform Head cleaning.	 <a href="#">6.5.2 Head cleaning</a>
3	Did you perform Alignment?	Perform Alignment.	 <a href="#">3.7 Adjust print</a>
4	Did you perform Media feed adjustment?	Perform Media feed adjustment.	 <a href="#">4.2.6 Media feed adjustment</a>

**(5) Printing lines are not straight**

No.	Possible cause	Remedy	Reference
1	Is the ink cartridge within the validity period?	Use a new ink cartridge.	 <a href="#">6.4.1 Replacing ink cartridges</a>
2	Did you perform Alignment?	Perform Alignment.	 <a href="#">3.7 Adjust print</a>
3	Did you perform Media feed adjustment?	Perform Media feed adjustment.	 <a href="#">4.2.6 Media feed adjustment</a>

**(6) Printing lines are duplicated or patchy**











No.	Possible cause	Remedy	Reference
1	Is the nozzle in good condition?	Perform Head cleaning.	 <a href="#">6.5.2 Head cleaning</a>

## 7.2 Error messages









This section describes messages displayed during normal printer operation or when errors occur, and solutions to the messages.

### 7.2.1 Status messages

When the product is operating correctly, each operation status is displayed as below.

No.	Display	Description	Reference
1	Ready to Print	Standby (Media is loaded).	—
2	Media End	Standby (Media is not loaded).	 <a href="#">3.5 Setting media</a>
3	Receiving	Receiving data.	—
4	Converting	Analyzing data.	—
5	Printing	Under printing.	—
6	Remain:XXX.Xm	Displays the length of the data that has not been printed in meters for the data currently being printed.	 <a href="#">4.4.6 Normal Display while Printing</a>
7	Remain Time: Xmin	Displays the time remaining to print in minutes for the data currently being printed.	 <a href="#">4.4.6 Normal Display while Printing</a>
8	Cleaning **%	Cleaning the head. Please wait a while.	 <a href="#">6.5.2 Head cleaning</a>
9	During Washing	<ul style="list-style-type: none"> <li>Initial charging, ejecting filler fluid.</li> <li>Washing the print head by cleaning fluid.</li> </ul> Please wait a while.	 <a href="#">3.4 Initial ink charging</a>  <a href="#">6.3 Before using sleep mode for a long time</a>
10	Moving Origin Pos.	The print head is moving to the original printing position in the Origin setup menu. Please wait a while.	 <a href="#">5.3.4 Origin menu</a>
11	** Initializing **	Initializing the setting in the Initialization menu. Please wait a while.	 <a href="#">5.3.19 Initialization menu</a>
12	** Press 2sec. **	The [Cleaning] key or the [Nozzle Check] key is pressed for less than 2 seconds. Press the key for more than 2 seconds again.	 <a href="#">2.2.3 Operation panel</a>
13	[*****] S/C Reading	Reading the S/C card.	—
14	Ink Circulation	Ink is circulating inside the printer.	—
15	Start Ink Charge ->E	Ink charging starts. Please wait a while.	 <a href="#">3.4 Initial ink charging</a>  <a href="#">5.7 Maintenance menu</a>

No.	Display	Description	Reference
16	Ink Comb.: *Color	Select the ink type you want to use from 4-color set or 5-color set.	<a href="#">☞ 3.4 Initial ink charging</a>
17	Insert CleaningCart.	Washing Print head. Install the cleaning cartridges.	<a href="#">☞ 5.7.3 Ink Discharge menu</a>
18	Remove Cartridges	Washing Print head. Remove the cleaning cartridges.	<a href="#">☞ 5.7.3 Ink Discharge menu</a>
19	Ink Refill **%	Charging the ink. Please wait a while.	<a href="#">☞ 3.4 Initial ink charging</a>
20	Lever Up	Front Media set lever is up or Rear Media set lever is down. Set the media.	<a href="#">☞ 3.5.2 Loading rigid media</a> <a href="#">☞ 3.5.5 Setting roll media</a>
21	Media: Type ** OK?	Initializing the media. Please wait a while. (** represents the setup media type.)	<a href="#">☞ 3.5.2 Loading rigid media</a> <a href="#">☞ 3.5.5 Setting roll media</a>
22	Change: *.* ->	<ul style="list-style-type: none"> <li>The head height setting value detected for the media's thickness is displayed.</li> </ul>	—
23	Thick. + Adj: *.* + ○.○	The setting value (*.*) and the input adjustment value (○.○) are each displayed.	—
24	Media Initial	Detecting media.	—
25	Warning!*. * mm	Media thickness detection is set to Off. Check whether the thickness of the media loaded is as displayed; if it is wrong, enter the correct value.	<a href="#">☞ 3.5.6 Setting media type</a> <a href="#">☞ 3.5.7.2 When the media thickness detection is OFF</a>
26	Misuse Damage Unit>	Warns that the wrong setting for the media thickness may damage Print head. <ul style="list-style-type: none"> <li>To proceed, press the [&gt;] key for a while.</li> </ul>	<a href="#">☞ 3.5.6 Setting media type</a> <a href="#">☞ 3.5.7.2 When the media thickness detection is OFF</a>
27	<E> Skip, <CAN> Detect	<ul style="list-style-type: none"> <li>Press the [Enter] key to skip the media thickness detection.</li> <li>Press the [Cancel] key to detect the media thickness.</li> </ul>	<a href="#">☞ 3.5.6 Setting media type</a> <a href="#">☞ 3.5.7.2 When the media thickness detection is OFF</a>
28	Cover Open	The front cover is open.	<a href="#">☞ 3.5 Setting media</a>
29	Mainte.CoverL Open	The left maintenance cover is open.	
30	Mainte.CoverR Open	The right maintenance cover is open.	

No.	Display	Description	Reference
31	Start Sleep Mode?	Waiting to activate Sleep Mode. Press the [Enter] key to activate Sleep Mode.	 <a href="#">5.1 Sleep mode menu</a>
32	CR Mainte.: Start	Waiting to activate CR maintenance. <ul style="list-style-type: none"> <li>To perform daily maintenance, press the [Enter] key.</li> <li>When daily maintenance has already been performed, press the [Cancel] key.</li> </ul>	 <a href="#">3.2.2 Turning the power OFF</a>  <a href="#">3.3.1 Set sleep mode on the printer</a>
33	"Wait for a while..."	Indicates that the printer's status is being changed. Please wait a while.	—
34	CR Mainte.: End	Perform daily maintenance. After daily maintenance is complete, press the [Enter] key.	 <a href="#">3.2.2 Turning the power OFF</a>  <a href="#">3.3.1 Set sleep mode on the printer</a>
35	Restart -> Enter	During Sleep Mode. Press the [Enter] key to return the printer to Normal operation.	 <a href="#">3.3.1 Set sleep mode on the printer</a>
36	Power Off	Turning OFF the printer. Wait for a while.	 <a href="#">3.2.2 Turning the power OFF</a>
37	Close right mainte. cover.	Indicates that five minutes have passed during daily maintenance. Close Maintenance cover, stop the operation, and then perform Head cleaning.	 <a href="#">3.2.2 Turning the power OFF</a>  <a href="#">3.3.1 Set sleep mode on the printer</a>
38	Close left mainte. cover.		
39	Head Height Initial	Initializing the head height. Please wait a while.	 <a href="#">3.5.6 Setting media type</a>

**TIP**











- The value of the Authorization Code may be displayed for the display of the option function.
- For details, contact your local MUTOH dealer.









## 7.2.2 Error message display and remedies

Error messages are displayed when certain failures occur during printer operation.

If an error that can be displayed occurs, the printer may display the following error messages and stop operation.

If the printer stops operating, solve the error so that the printer restarts.

No.	Display	Description	Remedy	Reference
1	Undefined Media	Failed in identifying the media. (Stops operation)	Reload the media.	 <a href="#">3.5 Setting media</a>
2	Media Slant	The media was not fed straight. (Stops operation)	Reload the media.	 <a href="#">3.5 Setting media</a>
3	End Of Roll	The roll media has run out. (Stops operation)	Load a new roll media.	 <a href="#">6.4.2 Replacing roll media</a>
4	[*****] Ink NearEnd	The remaining amount of ink is low. (Continues operation)	Replace with a new ink cartridge.	 <a href="#">6.4.1 Replacing ink cartridges</a>
5	[*****] InkEnd	Ink has run out. (Stops operation)	Replace with a new ink cartridge.	 <a href="#">6.4.1 Replacing ink cartridges</a>
6	[*****] NoCartridge	Ink cartridge is not inserted. (Stops operation)	Insert Ink cartridge.	 <a href="#">6.4.1 Replacing ink cartridges</a>
7	[*****] Discharged	Ink is not filled.	Perform initial ink charging.	 <a href="#">3.4 Initial ink charging</a>
8	Full WasteInkTank	The waste fluid tank is full. (Stops operation)	Dispose of waste fluid.	 <a href="#">6.6 Disposal the waste fluids</a>
9	Life Times [Pump]	The operational life of the pump motor has almost expired. (Continues operation)	Contact your local MUTOH dealer.	—
10	Life Times [CR Motor]	The life CR motor is almost expired. (Continues operation)	Contact your local MUTOH dealer.	—
11	Life Times [PF Motor]	The operational life of the PF motor has almost expired. (Continues operation)	Contact your local MUTOH dealer.	—
12	Life Times [C Pump]	The operational life of Circulation pump motor is almost expired. (Continues operation)	Contact your local MUTOH dealer.	—
13	Life Times [UV LED]	The operational life of UV LED has almost expired. (The operation continues.)	Contact your local MUTOH dealer.	—
14	Don't Start Sleep Mode	Sleep Mode cannot be performed because the printer is not normal condition. (Stops operation)	Return the product normally.	 <a href="#">5.1.1 Timer Setting menu</a>  <a href="#">5.1.3 Sleep Mode Start menu</a>

No.	Display	Description	Remedy	Reference
15	[****] S/C ReadErr	Reading S/C Card has been failed.	Insert ink cartridge again. If S/C Card still cannot be read, insert new ink cartridge.	 <a href="#">6.4.1 Replacing ink cartridges</a>
16	[****] S/C Col.Err	ink cartridges are inserted in wrong slots.	Insert ink cartridges correctly again.	 <a href="#">6.4.1 Replacing ink cartridges</a>
17	[*] S/C Ink Err	The ink cartridge cannot be used for this printer.	Contact your local MUTOH dealer.	 <a href="#">6.4.1 Replacing ink cartridges</a>
18	[*] S/C CodeErr	Inserted ink cartridge is not a proper one.	Contact your local MUTOH dealer.	—
19	[*] Broken Chip	S/C Card has been broken.	Insert new ink cartridge.	 <a href="#">6.4.1 Replacing ink cartridges</a>
20	Ready to Print/PFErr	PF origin sensor could not detect the origin position for feeding.	You can still print, but print quality is not guaranteed. If this still does not clear the problem, contact your local MUTOH dealer.	—
21	Shake W Cartridge	Shake the White (Wh) ink cartridge.	Shake the White (Wh) ink cartridge.	 <a href="#">6.1 Wearing the gloves and goggles</a>
22	Shake KMCY Cartridge	Shake the Black (K), Magenta (M), Cyan (C), and Yellow (Y) ink cartridges.	Shake the Black (K), Magenta (M), Cyan (C), and Yellow (Y) ink cartridges.	 <a href="#">6.1 Wearing the gloves and goggles</a>
23	Shake ALL Cartridge	Shake all ink cartridges.	Shake the Black (K), Magenta (M), Cyan (C), and Yellow (Y) ink cartridges.	 <a href="#">6.1 Wearing the gloves and goggles</a>
24	Shake KMCYWC cartridge	Shake the Black (K), Cyan (C), Magenta (M), Yellow (Y), and White (Wh) ink cartridges.	Shake the Black (K), Cyan (C), Magenta (M), Yellow (Y), and White (Wh) ink cartridges.	 <a href="#">6.1 Wearing the gloves and goggles</a>
25	[*] Change Plug	Connector rubber for Highcapacity pack adapter is at the end of its life.	Replace Connector rubber of High-capacity pack adapter.	 Operation manual for High-Capacity Ink Pack Adapter “3.1 Installing High-Capacity Ink Pack Adapter”

No.	Display	Description	Remedy	Reference
26	Life Warning [CPump]	You must replace the Circulation Pump. Please contact your Mutoh dealer to replace the Circulation-Pump.	<p>If you want to stop the beep and continue printing, follow these steps.</p> <ol style="list-style-type: none"> <li>1. Press the [Enter] or [Cancel] key to stop the beep.</li> <li>2. The message "MaintenanceCall?" appears. Use the [+]/[-]key to select [Yes] or [No].</li> <li>3. Press the [Enter] key. <ul style="list-style-type: none"> <li>• When [Yes] is selected, the message "Ready To Print" will appear. You can continue printer operation.</li> <li>• When [No] is selected, the message "Printer Stop Shortly" will appear. Go to Step 4.</li> </ul> </li> <li>4. Press the [Enter] key. The message "Ready To Print" appears.</li> </ol>	
27	Replace [CPump]	The Circulation Pump reached the end of the life cycle. You cannot operate the printer from the operation panel until replacing the pump.	<ol style="list-style-type: none"> <li>1. Press the [Enter] or [Cancel] key to stop the beep.</li> <li>2. Contact your dealer immediately to replace the Circulation-Pump. In this stage, the automatic ink maintenance will no longer work. The printer performance after the replacement cannot be guaranteed.</li> </ol>	

**NOTE**

The color inside [\*\*\*\*\*] in the error display represents the ink color with a problem. If the error applies to all ink cartridges, [ALL] is displayed.



### 7.2.3 Data error display and solutions

A data error appears if there is a failure in data communication between your PC and the printer. If a data error occurs, the following error message appears and operation stops. When the cause of the error is solved, the printer starts operating again.

No.	Display	Description	Remedy	Reference
1	I** Error [ ]	An error occurred when receiving data.	Check the communication requirements between the printer and your PC.	 <a href="#">4.3 Menu setups on the operation panel</a>

#### NOTE

“\*\*\*” in the error message is the code No. that indicates what type of error occurred.

### 7.2.4 Command error display and remedies

A command error is displayed if a certain failure occurs during analysis of the command data sent from your PC to the printer. If a command error occurs, the following error message appears and operation stops. When the error is solved, the printer starts operating again.

No.	Display	Description	Remedy	Reference
1	MH** Error [ ]	An invalid command has been sent from the computer.	Check that the settings on your PC and the printer are the same.	 <a href="#">4.3 Menu setups on the operation panel</a>

#### NOTE

- “\*\*\*” in the error message is the code no. that indicates what type of error occurred.
- The command code representing the error occurred may be indicated in [ ].
- For the settings on your PC side, refer to the Operating Manual attached with your PC.

## 7.2.5 Error requiring restart

An error requiring restart is displayed if a fatal operational failure such as the following occurs.

- When an obstacle that prevents printing occurs
- When a problem occurs with the electrical circuit (PCB, motor, sensor, etc.) of the printer
- When a failure in the printer control program occurs

If an error requiring restart occurs, the printer stops operating after performing the following operations.



1. The drive power automatically shuts down.
2. All lamps blink, and the buzzer rings continuously.
3. The error message is displayed.

Pressing any key stops the beeping.

For an error requiring restart, operation will return to normal after removing the cause of the error and restarting the printer.

If the same error continues to be displayed, contact the your local MUTOH dealer.

Be sure to tell us the code no. of the error message when you contact us.

No.	Display	Description	Remedy	Reference
1	E** Error [ ]	A problem that does not have a remedy has occurred.	<ol style="list-style-type: none"> <li>1. Remove obstacles such as paper scraps in the drive system.</li> <li>2. Confirm that the replaced items are correctly attached.</li> <li>3. Turn OFF the printer power, and turn it ON again after 10 seconds or longer.</li> </ol>	<p> <a href="#">7.3 The media is jammed</a></p> <p> <a href="#">6.4 Replacing consumable components</a></p>

### NOTE

- “\*\*\*” in the error message is the code no. that indicates what type of error occurred.
- The command code representing the error occurred may be indicated in [ ].
- For the settings on your PC side, refer to the Operating Manual attached with your PC.

## 7.3 The media is jammed

When the set media is jammed, follow the procedure below to remove it.

### 7.3.1 Removing Thick Media

If thick media becomes jammed, contact your local MUTOH dealer.

### 7.3.2 Removing Roll Media

1. Turn OFF the power of the printer.  
[☞ 3.2.2 Turning the power OFF](#)

2. Open the front cover.

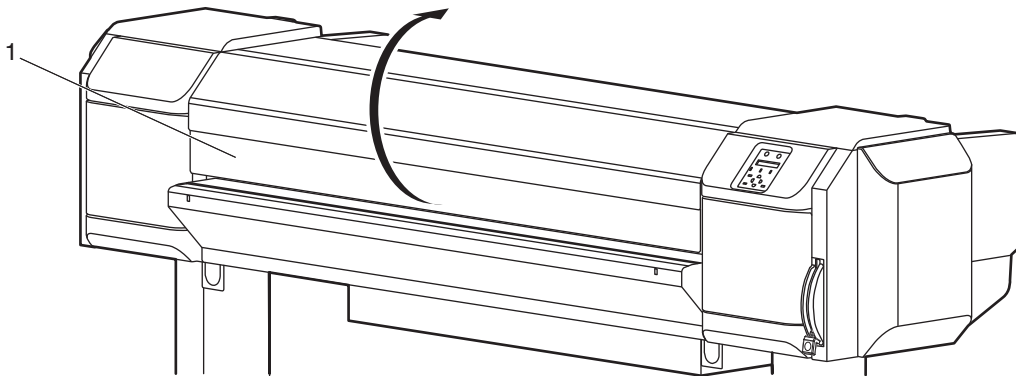

No.	Name
2	Front cover

3. Move the print head section from the top of the media to the right.

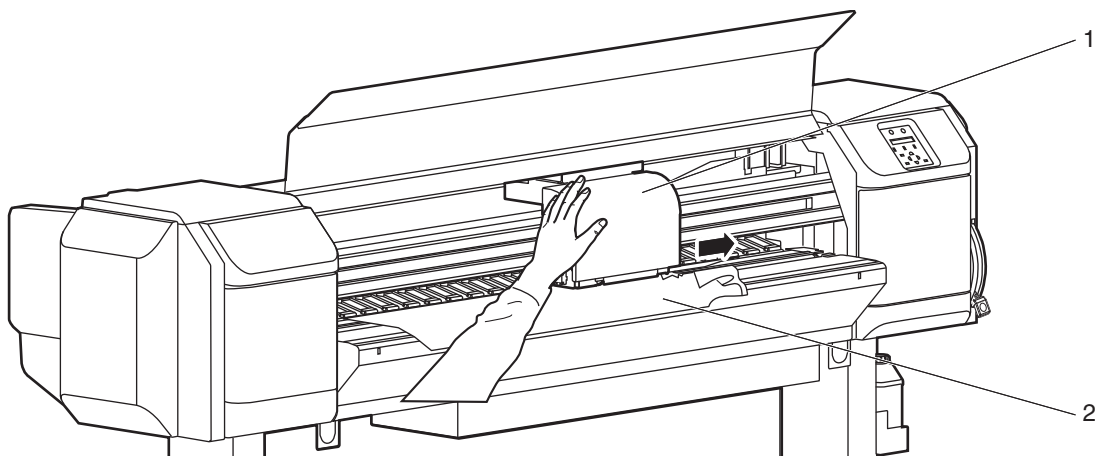

No.	Name
1	Print head section
2	Roll media

4. Raise Front media loading lever (lower Rear media loading lever).

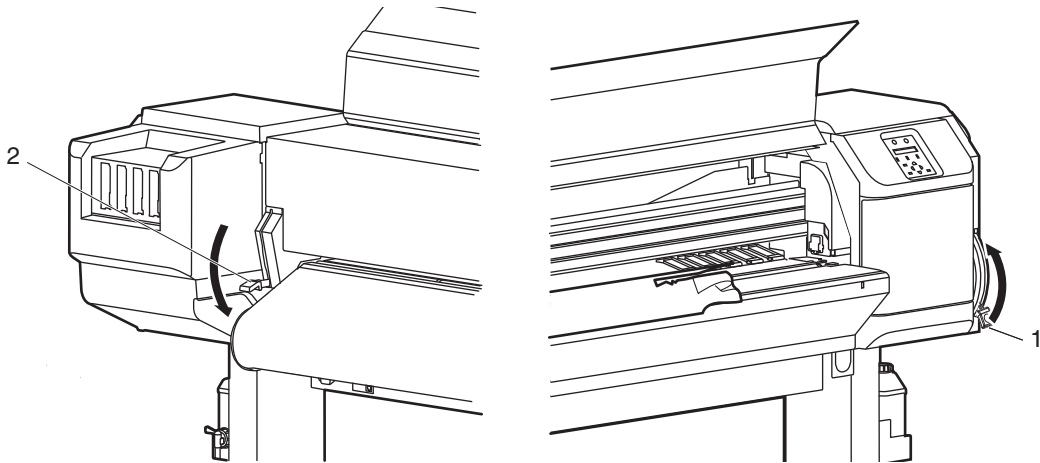

No.	Name
1	Media loading lever

5. Pull the media to your side, and cut the torn part with cutting tools such as a razor blade.

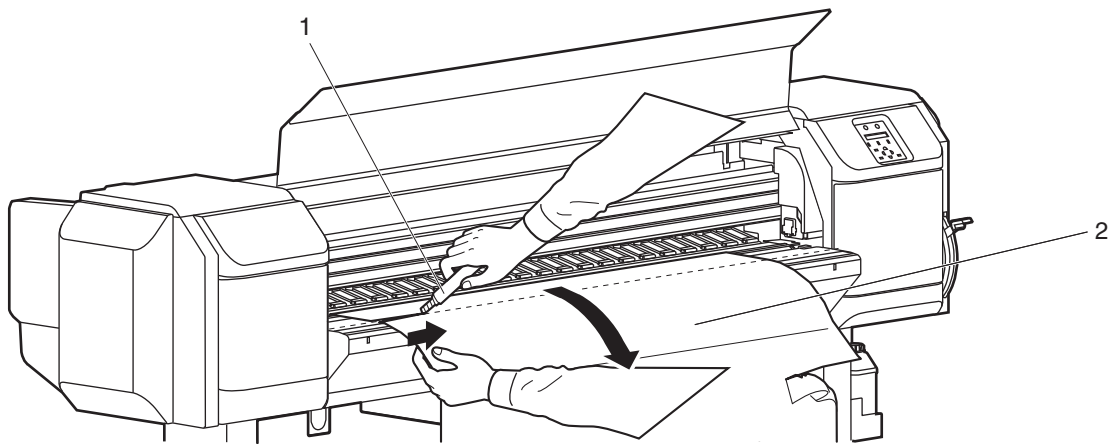

No.	Name
1	Razor blade
2	Roll media

6. Turn the flanges of the roll media holder and take up the roll media.

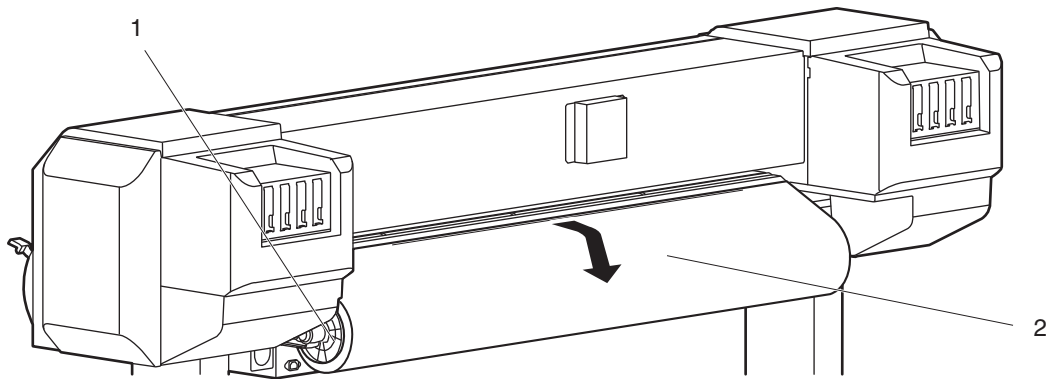

No.	Name
1	Flanges
2	Roll media

7. If paper dust or pieces of paper remain inside the printer, remove them.



## 8 Appendix

This chapter describes specifications and optional componets with this printer.

## 8.1 Product specifications

### 8.1.1 Printer specifications

Item		Specification
Model name		VJ-1626UH
Printing method		On-demand piezo drive system
Drive system		Firmware servo/DC motor drive
Media feed system		Multipoint pressurizing grid roller system
Media fixing system		Pressurization roller down system by manual lever
Media feed/ejection		Roll media: Rear feeding/Front ejecting Thick media: Rear feeding/Front ejecting
Thick media	Weight	15 kg or less
	Maximum length	1,200 mm
	Maximum width	1,625 mm
	Maximum thickness	15 mm (warpage of less than 1 mm)
	Maximum print width	1,615 mm
Roll media	Outer diameter	150 mm or less
	Tube diameter	2 or 3 inch
	Weight	30 kg or less
	Maximum width	1,625 mm
	Maximum thickness	0.3 mm
	Maximum print width	1,615 mm
Print margin		<Thick Media> Front: Max 5 mm(When layer printing: 25 mm), Rear: Max 40 mm, Left: 5 mm to 25 mm, Right: 5 mm to 25 mm <Roll Media> Front: Max 15 mm(When layer printing: 35 mm)(For continuous print: 5 mm), Rear: 5 mm (Maximum end edge of media is 40 mm), Left: 5 mm to 25 mm, Right: 5 mm to 25 mm
Media cut system		Horizontal manual cut system
Head height adjustment		Automatic height adjustment
CPU		64-bit RISC CPU
Memory		384MB
Command		MH-RTL (RTL-PASS)
Interface		Ethernet (10BASE-T/100BASE-TX)
Ink	Supply system	Supplied through tubes from independent color cartridges
	Ink cartridge	Black, Cyan, Magenta, Yellow, White, Varnish: 220 ml each (7.43fl oz each)



Item		Specification	
Environmental condition	Operating condition	Temperature: 20 °C to 32 °C Humidity: 40% to 60%, No condensation	
	Printing accuracy coverage	Temperature: 22 °C to 30 °C Humidity: 40% to 60%, No condensation	
	Change rate	Temperature: within 2 °C per one hour Humidity: within 5% per one hour	
	Archiving condition (Ink not filled)	Temperature: -20°C to 60°C Humidity: 20% to 80%, No condensation Storage life: six months	
	Archiving condition (Ink filled)	Temperature: 5°C to 30°C Humidity: 20% to 80%, No condensation Storage life: 30 days (Perform the maintenance operation written in the operation manual.)	
Power	Rated voltage	AC 100-240V	
	Range of voltage input	AC 90V-132V/180V-264V	
Power consumption	Printing	(AC 100-120 V ± 10%) Max. 300W	(AC 200 -240 V ± 10%) Max. 300W
	Standby	40 W or less (When the idle heat is turned OFF)	
Outer diameter	Height	1,261 mm (including the stand) 1,302 mm (including media-feed table)	
	Width	2,698 mm	
	Depth	2,730 mm (including media-feed table) 818 mm (main unit only)	
Weight		Approx. 202 kg (including the stand)	

## 8.2 Interface specification

This section describes each type of interface specifications supported by this product.

### 8.2.1 Network interface specification

Item	Specification
Network type	Ethernet IEEE802.3
Network I/F	10BASE-T/100BASE-TX Automatic transfer type (RJ-45 Connector twist pair cable) MDI/MDI-X Automatic transfer
Corresponding protocol	TCP/IP

## 8.3 Options/Supply list

For more information about the options and the supply items, contact your local MUTOH dealer.



## 9 Setup menu diagram

For details of the Setup menu configuration diagram, refer to the followings.

**NOTE**

- For details of each setup item, refer to followings:
  - Setup menu diagram (Ready to Print):  
☞ [5 Panel setup menu](#)
  - Setup menu diagram (Receiving / Converting / Printing):  
☞ [4.4.4 Changing and confirming settings while printing](#)
  - The < > parts in each list are factory default settings (initial values).
-

# Setup menu diagram (Ready to Print) (1/4)

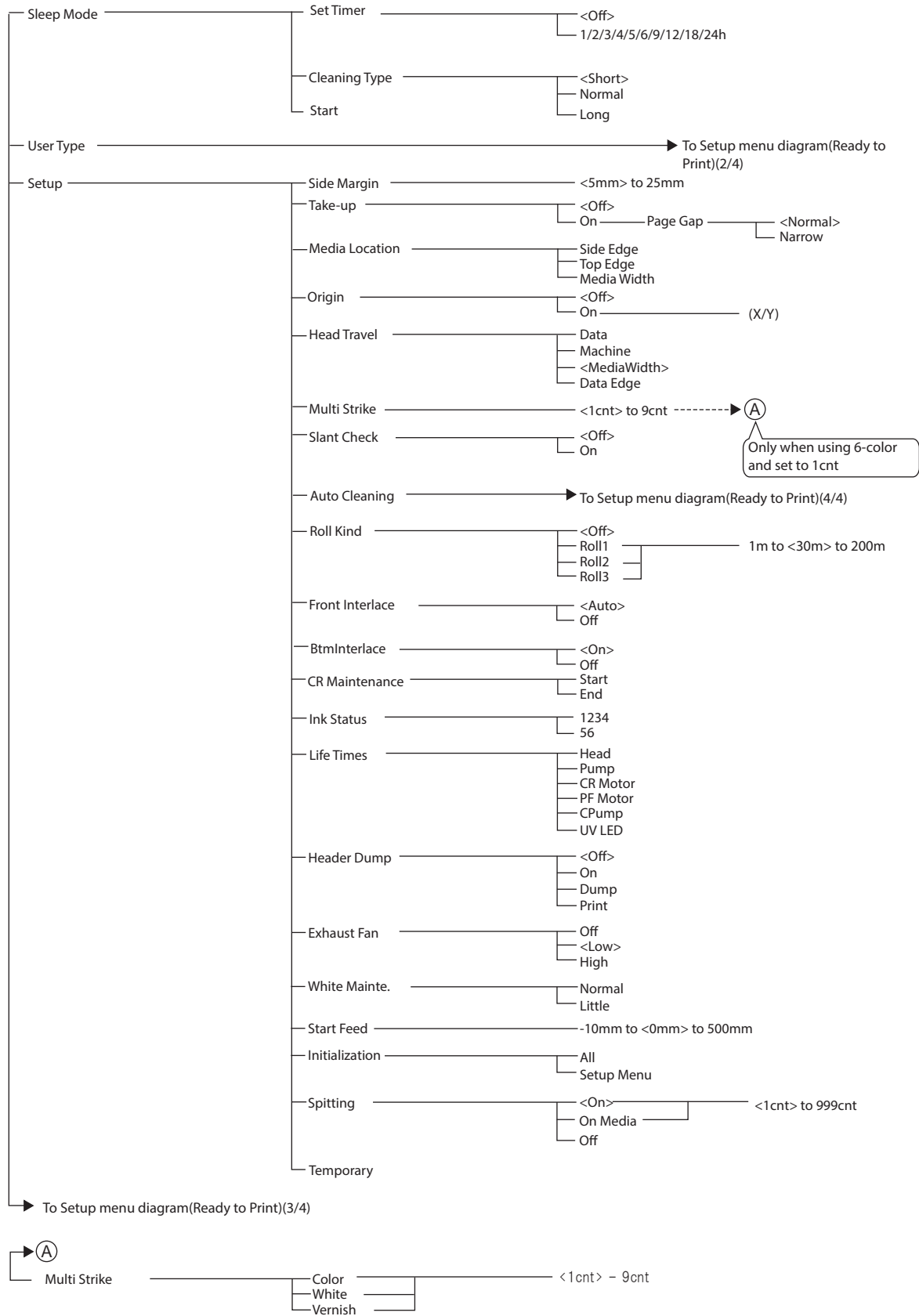

# Setup menu diagram (Ready to Print) (2/4)

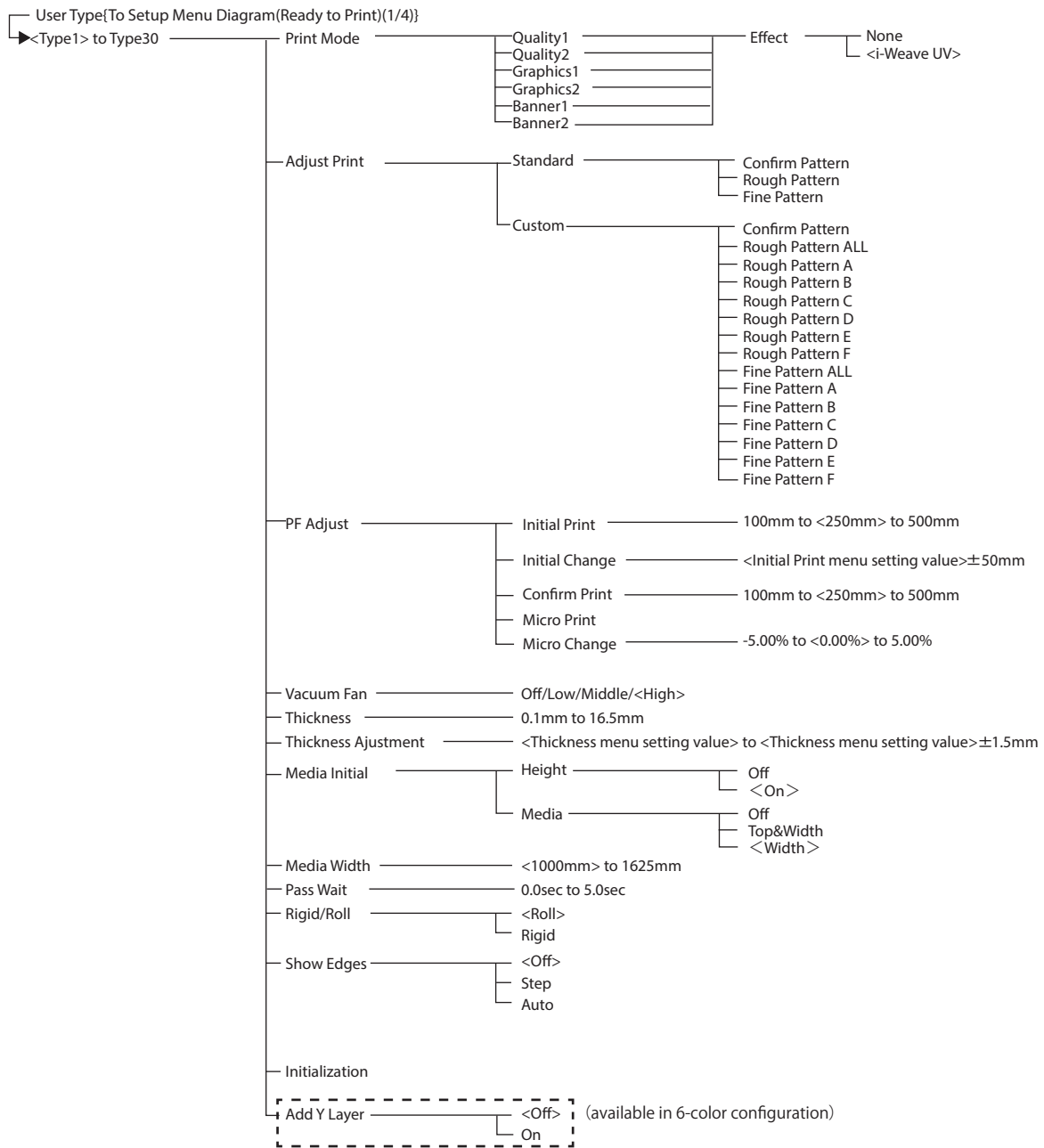

# Setup menu diagram (Ready to Print) (3/4)

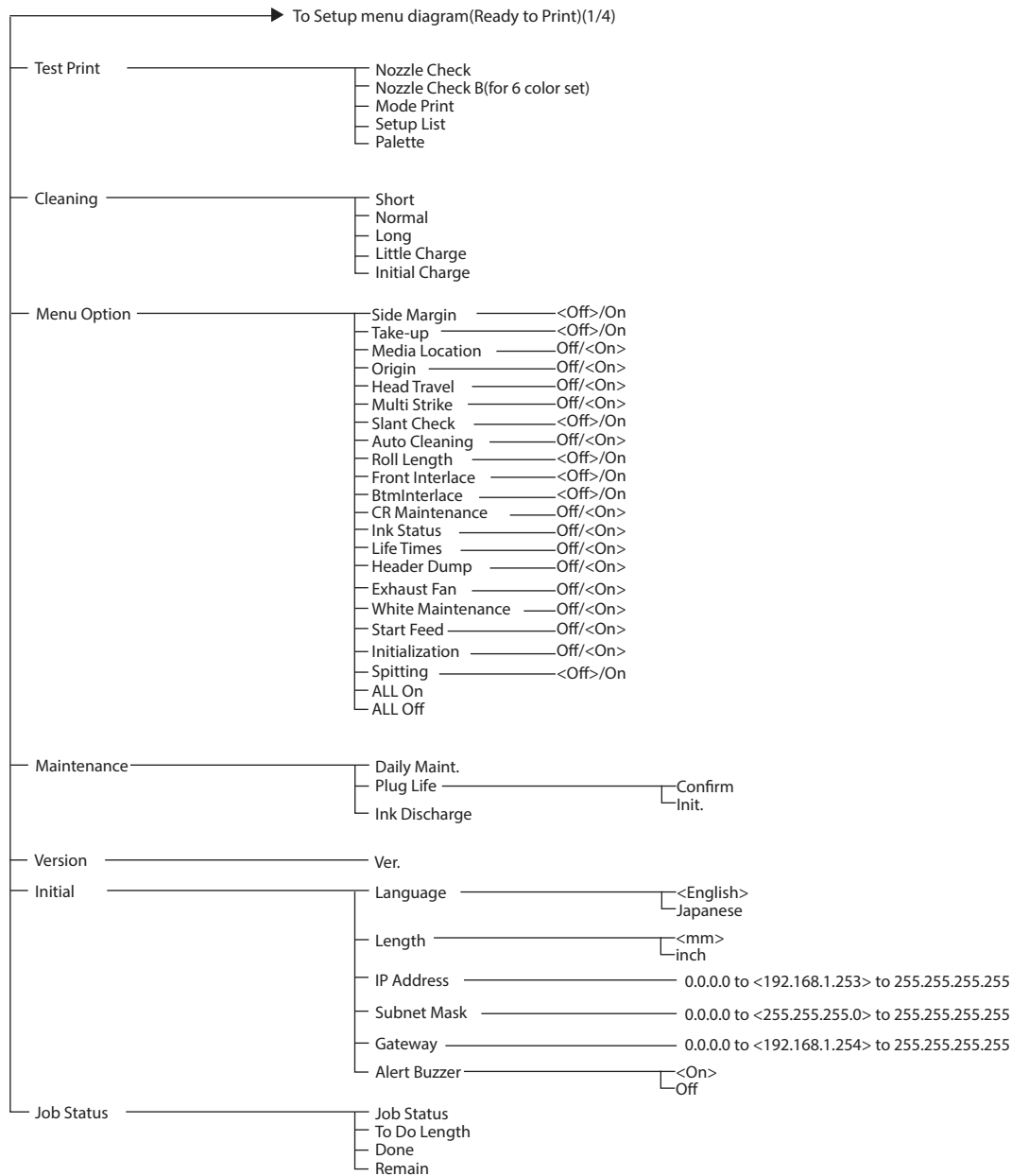



## Setup menu diagram (Ready to Print) (4/4)

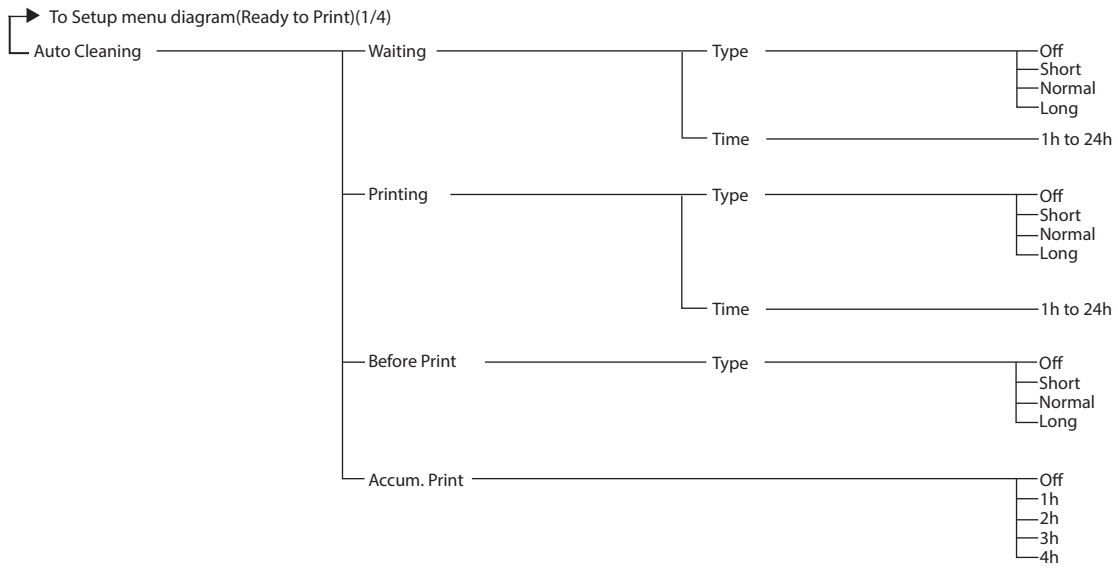

# Setup menu diagram (Receiving/Converting/Printing)

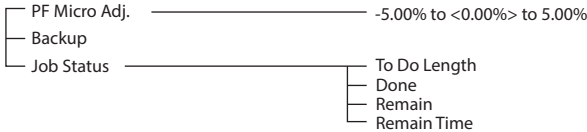

## Revision History

### General Information

Date	Version	Manual code	Supported Firmware
2014.3	00	VJ1626UHE-A-00	V.1.00
2014.6	01	VJ1626UHE-A-01	V.1.02
2016.10	02	VJ1626UHE-A-02	V.1.06
2020.11	03	VJ1626UHE-A-03	V.1.08 or later

**MUTOH**